

Beechcraft®

Baron® 95-B55

(Serials TC-371, TC-502
thru TC-1607)
(Includes Gr. Wt. Kit 55-4014)

and

95-B55A

**Special Reduced
Gross Weight
Configuration**

Pilot's Operating Handbook *and* FAA Approved Airplane Flight Manual

FAA Approved in the Normal Category based on CAR 3. This document must be carried in the airplane at all times and be kept within reach of the pilot during all flight operations.

This handbook includes the material required to be furnished to the pilot by CAR 3.

Airplane Serial Number: _____

Airplane Registration Number: _____

FAA Approved: _____

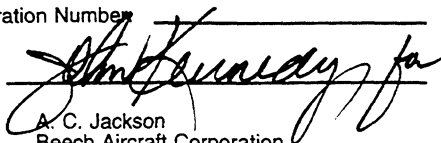

A. C. Jackson
Beech Aircraft Corporation
DOA CE-2

This handbook supersedes all BEECH published owner's manuals, flight manuals, and check lists issued for this airplane with the exception of FAA Approved Airplane Flight Manual Supplements.

COPYRIGHT © BEECH 1994

P/N 96-590011-25
Issued: October, 1978

P/N 96-590011-25A5
Revised: July, 1994

Published By
RAYTHEON AIRCRAFT COMPANY
P.O. Box 85
Wichita, Kansas 67201
U.S.A.

NOTE

Where Beech Aircraft Corporation or Beechcraft is referred to in this publication, it will be taken to read Raytheon Aircraft Company.

Exported under the authority of license exception: TSU.
"These commodities, technology or software were exported from the United States in accordance with Export Administration Regulations. Diversion contrary to U.S. law prohibited."

Raytheon Aircraft

Beech
Hawker



Member of GAMA

General Aviation
Manufacturers Association

Raytheon Aircraft

Baron 95-B55/95-B55A

Log of Temporary Changes

to the

Pilot's Operating Handbook

and

FAA Approved Airplane Flight Manual

P/N 96-590011-25

Changes to this Pilot's Operating Handbook and FAA Approved Airplane Flight Manual must be in the airplane for all flight operations.

Part Number	Subject	Date
96-590011-25TC1	Fuel Selector Placard Installation	Aug 26, 1997

Note: This page should be filed in the front of the *Pilot's Operating Handbook and FAA Approved Airplane Flight Manual* immediately following the *Title* page. This page replaces any *Log of Temporary Changes* page dated prior to the date in the lower right corner of this page.

**BARON 95-B55 AND 95-B55A
(TC-371, TC-502 THRU TC-1607)
PILOT'S OPERATING HANDBOOK
AND**

FAA APPROVED AIRPLANE FLIGHT MANUAL

A5 Revision July, 1994

LOG OF REVISIONS

Page	Description
Title Page	Updated
Page A (A5)	New
10-1 thru 10-64	Revised Section X, Safety Information (May, 1994)

A5

**BARON 95-B55 AND 95-B55A
(TC-371 AND TC-502 THRU TC-1607)
PILOT'S OPERATING HANDBOOK
AND
FAA APPROVED AIRPLANE FLIGHT MANUAL**

A4 Revision October, 1990

LOG OF REVISIONS

Page	Description
Title Page	Updated
Page A (A4)	New
10-1 thru 10-68	Revised Section X, Safety Information (October, 1990)

A4

**Baron 95-B55 (TC-371, TC-502 thru TC-1607)
Pilot's Operating Handbook
and
FAA Approved Airplane Flight Manual
P/N 96-590011-25**

LOG OF REVISIONS

"A3 Revision" March, 1988

Page	Description
Title Page Page A (A3)	Updated New
2-11	Revised "Kinds of Operation"
2-13	Revised "WARNING"
4-20, 4-21	Revised "ICE PROTECTION SYSTEMS", Changed "CAUTION" to "WARNING"
4-22	Shifted Material

A3

**Baron 95-B55 (TC-371, TC-502 thru TC-1607)
Pilot's Operating Handbook
and
FAA Approved Airplane Flight Manual**

A2 March 1983

LOG OF REVISIONS

PAGES	DESCRIPTION
Title Page	Update
Logo Page	Added
Page A (A2)	New
a & b	Revise "Introduction" and Add "Warning"
1-1	Update Table of Contents
1-3, 1-4	Revise "Important Notice"
1-5, 1-6, 1-6A & 1-6B	Revise "NOTE" and "Airplane Flight Manual Supplements Revision Record" and Shift Material
2-30	Revise "Emergency Exit" Placard
3-2	Update Table of Contents
3-3, 3-4	Revise "Emergency Airspeeds," Add "Stall Warning Horn" Advisory and Shift Material
3-16	Revise "Emergency Exits"
4-1	Update Table of Contents
4-3	Revise "Airspeeds for Safe Operation"
4-8, 4-8A	Revise "Starting" and "After Starting and Taxi" and Shift Material
4-9	Revise "Before Takeoff"
5-33	Revise "Recommended Cruise Power RPM"
7-1 and 7-2	Update Table of Contents
7-12B, 7-13, 7-14 & 7-15	Revise "Openable Cabin Windows," Add "Emergency Exits" and Shift Material
7-16	Revise "Control Locks"
8-2	Update Table of Contents
8-26A, 8-26B & 8-27	Revise "Cleaning - Exterior Painted Surfaces"
8-28	Revise "Windshield and Windows"
8-42, 8-42A, 8-42B & 8-43	Revise "Consumable Materials"

A2

Baron B55
(TC-371, TC-502 thru TC-1607)
Pilot's Operating Handbook
and FAA Approved
Airplane Flight Manual

LOG OF REVISIONS

A1 July 1980

PAGE	DESCRIPTION OF REVISION
Title Page	Update
Page A(A1)	Update
1-1	Update Table of Contents
1-5	Revise Note
1-6A, 1-6B	Add "Vendor-Issued STC Supplements
1-18	Revise "Demonstrated Crosswind Velocity"
2-24	Revise "Placard Position Information"
2-29	Revise "Placard Position Information"
4-7, 4-8	Revise "Starting" Procedure
7-1	Update Table of Contents
7-5	Revise "Control Column"
7-6, 7-7	Shift material
7-12	Revise "Brakes" and shift material
7-12A	Shift material
7-12B	Shift material
7-13	Shift material
7-33	Revise "Heating and Ventilation System Schematic"
8-30	Revise "Lubrication Points"
8-33	Revise "Lubrication Points"
8-38	Revise "Lubrication Schedule"
8-39	Revise "Lubrication Schedule"
8-42	Revise "Consumable Materials"
8-43	Revise "Consumable Materials"
8-49	Revise "Power Plant"
8-52	Revise "Power Plant" *note
<div style="border: 1px solid black; padding: 10px; margin: 10px auto; width: 80%;"> <p style="text-align: center;">10-1 thru 10-67 Revised Safety Section Dated March 1981</p> </div>	
<div style="border: 1px solid black; padding: 5px; display: inline-block;"> <p style="margin: 0;">A1</p> </div>	

**Baron B55
(TC-371, TC-502 thru TC-1607)**

**Pilot's Operating Handbook
and FAA Approved
Airplane Flight Manual**

Original (A) October 1978

LOG OF REVISIONS

PAGES	DESCRIPTION OF REVISION
Title Page Page A a and b 1-1 thru 1-20 2-1 thru 2-34 3-1 thru 3-18 4-1 thru 4-26 5-1 thru 5-48 6-1 thru 6-28 7-1 thru 7-40 8-1 thru 8-52 Section 9 10-1 thru 10-38	See Log of Supplement

A

Baron B55
Serials TC-371, TC-502 thru TC-1607

INTRODUCTION

This Pilot's Operating Handbook and FAA Approved Airplane Flight Manual is in the format and contains data recommended in the GAMA (General Aviation Manufacturers Association) Handbook Specification Number 1. Use of this specification by all manufacturers will provide the pilot the same type data in the same place in all of the handbooks.

In recent years, BEEHCRAFT handbooks contained most of the data now provided, however, the new handbooks contain more detailed data and some entirely new data.

For example, attention is called to Section X SAFETY INFORMATION. BEEHCRAFT feels it is highly important to have SAFETY INFORMATION in a condensed form in the hands of the pilots. The SAFETY INFORMATION should be read and studied. Periodic review will serve as a reminder of good piloting techniques.

WARNING

Use only genuine BEEHCRAFT or BEEHCRAFT approved parts obtained from BEEHCRAFT approved sources, in connection with the maintenance and repair of Beech airplanes.

Genuine BEEHCRAFT parts are produced and inspected under rigorous procedures to ensure airworthiness and suitability for use in Beech airplane applications. Parts purchased from sources other than BEEHCRAFT, even though outwardly identical in appearance, may not have had the required tests and inspections performed, may be different in fabrication techniques and materials, and may be dangerous when installed in an airplane.

Baron B55
Serials TC-371, TC-502 thru TC-1607

Salvaged airplane parts, reworked parts obtained from non-BEEHCRAFT approved sources, or parts, components, or structural assemblies, the service history of which is unknown or cannot be authenticated, may have been subjected to unacceptable stresses or temperatures or have other hidden damage, not discernible through routine visual or usual nondestructive testing techniques. This may render the part, component or structural assembly, even though originally manufactured by BEEHCRAFT, unsuitable and unsafe for airplane use.

BEEHCRAFT expressly disclaims any responsibility for malfunctions, failures, damage or injury caused by use of non-BEEHCRAFT approved parts.

TABLE OF CONTENTS

SECTION I	General
SECTION II	Limitations
SECTION III	Emergency Procedures
SECTION IV	Normal Procedures
SECTION V	Performance
SECTION VI	Weight and Balance/Equipment List
SECTION VII	Systems Description
SECTION VIII	Handling, Servicing and Maintenance
SECTION IX	Supplements
SECTION X	Safety Information

SECTION I

GENERAL

TABLE OF CONTENTS

<i>SUBJECT</i>	<i>PAGE</i>
Important Notice	1-3
Use of the Handbook	1-4
Revising the Handbook	1-6A
Airplane Flight Manual	
Supplements Revision Record	1-6B
Vendor-Issued STC Supplements	1-6B
Airplane Three View	1-7
Ground Turning Clearance	1-8
Descriptive Data	1-9
Engines	1-9
Propellers	1-9
Fuel	1-11
Standard System	1-11
Optional System	1-11
Oil	1-11
Weights	1-11
Cabin and Entry Dimensions	1-12
Baggage Space and Entry	
Dimensions	1-12
Specific Loadings	1-12
Symbols, Abbreviations and Terminology	1-12
Airspeed Terminology	1-13
Meteorological Terminology	1-15
Power Terminology	1-16
Engine Controls and Instruments	1-17
Revised: March 1983	1-1

Section I
General

BEEHCRAFT Baron B55
TC-371, TC-502 thru TC-1607

TABLE OF CONTENTS (Continued)

<i>SUBJECT</i>	<i>PAGE</i>
Airplane Performance and Flight	
Planning Terminology	1-18
Weight and Balance Terminology	1-19

THANK YOU . . . for displaying confidence in us by selecting a BEEHCRAFT airplane. Our design engineers, assemblers and inspectors have utilized their skills and years of experience to ensure that the BEEHCRAFT Baron meets the high standards of quality and performance for which BEEHCRAFT airplanes have become famous throughout the world.

IMPORTANT NOTICE

This handbook must be read carefully by the owner and operator in order to become familiar with the operation of the BEEHCRAFT Baron. The handbook presents suggestions and recommendations to help obtain safe and maximum performance without sacrificing economy. The BEEHCRAFT Baron must be operated according to the Pilot's Operating Handbook and FAA Approved Airplane Flight Manual, and/or placards located in the airplane.

As a further reminder, the owner and operator of this airplane should also be familiar with the Federal Aviation Regulations applicable to the operation and maintenance of the airplane and FAR Part 91 General Operating and Flight Rules. Further, the airplane must be operated and maintained in accordance with FAA Airworthiness Directives which may be issued against it.

The Federal Aviation Regulations place the responsibility for the maintenance of this airplane on the owner and the operator who must ensure that all maintenance is done by qualified mechanics in conformity with all airworthiness requirements established for this airplane.

All limits, procedures, safety practices, time limits, servicing, and maintenance requirements contained in this handbook are considered mandatory for the continued airworthiness of this airplane, in a condition equal to that of its original manufacture.

Authorized BEEHCRAFT Aero or Aviation Centers or International Distributors or Dealers can provide recommended modification, service, and operating procedures issued by both FAA and Beech Aircraft Corporation, which are designed to get maximum utility and safety from this airplane.

USE OF THE HANDBOOK

The Pilot's Operating Handbook is designed so that necessary documents may be maintained for the safe and efficient operation of the Baron. The handbook has been prepared in loose leaf form for ease in maintenance and in a convenient size for storage. The handbook has been arranged with quick reference tabs imprinted with the title of each section and contains ten basic divisions:

- Section 1 General
- Section 2 Limitations
- Section 3 Emergency Procedures
- Section 4 Normal Procedures
- Section 5 Performance
- Section 6 Weight and Balance/Equipment List
- Section 7 Systems Description
- Section 8 Handling, Servicing and Maintenance
- Section 9 Supplements
- Section 10 Safety Information

NOTE

Except as noted, all airspeeds quoted in this handbook are Indicated Airspeeds (IAS) and assume zero instrument error.

In an effort to provide as complete coverage as possible, applicable to any configuration of the airplane, some optional equipment has been included in the scope of the handbook. However, due to the variety of airplane appointments and arrangements available, optional equipment described and depicted herein may not be designated as such in every case.

The following information may be provided to the holder of this manual automatically:

1. Original issues and revisions of Class I and Class II Service Instructions
2. Original issues and revisions of FAA Approved Airplane Flight Manual Supplements
3. Reissues and revisions of FAA Approved Airplane Flight Manuals, Flight Handbooks, Owner's Manuals, Pilot's Operating Manuals, and Pilot's Operating Handbooks

This service is free and will be provided only to holders of this handbook who are listed on the FAA Aircraft Registration Branch List or the BEECHCRAFT International Owners Notification Service List, and then only if listed by airplane serial number for the model for which this handbook is applicable. For detailed information on how to obtain "Revision Service" applicable to this handbook or other BEECH-

CRAFT Service Publications, consult a BEEHCRAFT Aero or Aviation Center, International Distributor or Dealer, or refer to the latest revision of BEEHCRAFT Service Instructions No. 0250-010.

BEECH AIRCRAFT CORPORATION EXPRESSLY RESERVES THE RIGHT TO SUPERSEDE, CANCEL, AND/OR DECLARE OBSOLETE, WITHOUT PRIOR NOTICE, ANY PART, PART NUMBER, KIT OR PUBLICATION REFERENCED IN THIS HANDBOOK.

The owner/operator should always refer to all supplements, whether STC Supplements or Beech Supplements, for possible placards, limitations, normal, emergency and other operational procedures for proper operation of the airplane with optional equipment installed.

REVISING THE HANDBOOK

Immediately following the title page is the "Log of Revisions" page(s). The Log of Revisions pages are used for maintaining a listing of all effective pages in the handbook (except the SUPPLEMENTS section), and as a record of revisions to these pages. In the lower right corner of the outlined portion of the Log of Revisions is a box containing a capital letter which denotes the issue or reissue of the handbook. This letter may be suffixed by a number which indicates the numerical revision. When a revision to any information in the handbook is made, a new Log of Revisions will be issued. All Logs of Revisions must be retained in the handbook to provide a current record of material status until a reissue is made.

WARNING

When this handbook is used for airplane operational purposes, it is the pilot's responsibility to maintain it in current status.

AIRPLANE FLIGHT MANUAL
SUPPLEMENTS REVISION RECORD

Section IX contains the FAA Approved Airplane Flight Manual Supplements headed by a Log of Supplements page. On the "Log" page is a listing of the FAA Approved Supplemental Equipment available for installation on the airplane. When new supplements are received or existing supplements are revised, a new "Log" page will replace the previous one, since it contains a listing of all previous approvals, plus the new approval. The supplemental material will be added to the grouping in accordance with the descriptive listing.

NOTE

Upon receipt of a new or revised supplement, compare the "Log" page just received with the existing "Log" page in the manual. Retain the "Log" page with the latest date on the bottom of the page and discard the other log.

VENDOR-ISSUED STC SUPPLEMENTS

When a new airplane is delivered from the factory, the handbook delivered with it contains either an STC (Supplemental Type Certificate) Supplement or a Beech Flight Manual Supplement for every installed item requiring a supplement. If a new handbook for operation of the airplane is obtained at a later date, it is the responsibility of the owner/operator to ensure that all required STC Supplements (as well as weight and balance and other pertinent data) are transferred into the new handbook.

BEECHCRAFT Baron B55
TC-371, TC-502 thru TC-1607

Section I
General

Wing Area
199.2 sq. ft.

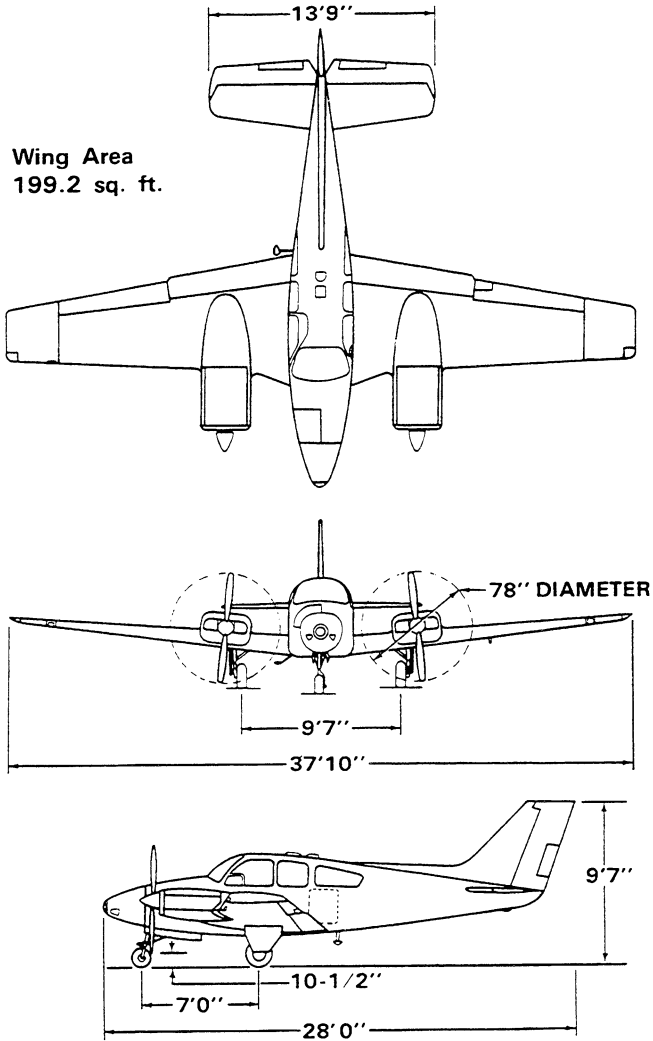

AIRPLANE THREE-VIEW

GROUND TURNING CLEARANCE

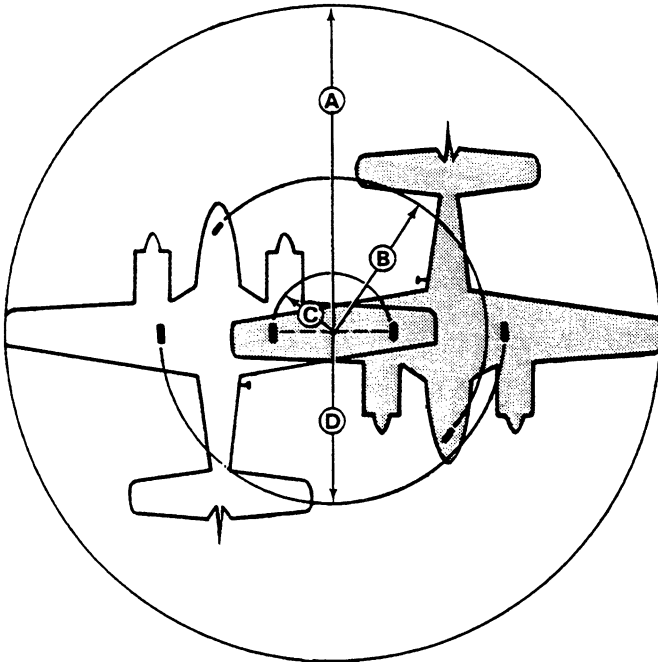

- (A) Radius for Wing Tip 29 feet 6 inches
- (B) Radius for Nose Wheel 12 feet 2 inches
- (C) Radius for Inside Gear 5 feet 9 inches
- (D) Radius for Outside Gear 15 feet 7 inches

TURNING RADII ARE PREDICATED ON THE USE OF PARTIAL BRAKING ACTION AND DIFFERENTIAL POWER.

DESCRIPTIVE DATA

ENGINES

Two Continental IO-470-L fuel injected, air cooled six-cylinder, horizontally-opposed engines each rated at 260 horsepower at 2625 rpm.

Take-off and Maximum

Continuous Power Full throttle and 2625 rpm
Maximum One-Engine

Inoperative Power Full throttle and 2625 rpm
Cruise Climb Power 25.0 in. Hg at 2500 rpm
Maximum Cruise Power 24.5 in. Hg at 2450 rpm

PROPELLERS

Propeller hubs and blades shall be identical on both engines.

McCAULEY

2 Blade Hubs: 2AF34C55

Blades: 78FF-0

Pitch Setting at 30 inch Station: Low 15°; high 79°

Diameter: Maximum 78 inches, minimum 76 inches

HARTZELL

2 Blade Hubs: BHC-C2YF-2CHF

Blades: FC8465-6

Pitch Setting at 30 inch Station: Low 16.0°;

Feathered 80.0°

Diameter: 78 inches, cut-off permitted to 76.5 inches

or

Section I
General

BEECHCRAFT Baron B55
TC-371, TC-502 thru TC-1607

2 Blade Hubs: BHC-C2YF-2CH

Blades: C8465-6

Pitch Setting at 30 inch Station: Low 16.0°;

Feathered 80.0°

Diameter: 78 inches, cut-off permitted to 76.5 inches

OR

3 Blade Hubs: PHC-A3VF-2B

Blades: V7636D

Pitch Setting at 30 inch Station:

Low 13.0° to 13.5°; High 84.0° to 86.0°

Diameter: Maximum 76.25 inches, No cut-off permitted

or

3 Blade Hubs: PHC-A3XF-2B

Blades: 7636D

Pitch Setting at 30 inch Station:

Low 13.0° to 13.5°; High 84.0° to 86.0°

Diameter: Maximum 76.25 inches, No cut-off permitted

OR

3 Blade Hubs: PHC-C3YF-2F

Blades: FC7663-2R

Pitch Setting at 30 inch Station: Low 13.5°; Feathered
84.0°

Diameter: 76 inches, cut-off permitted to 74.5 inches

or

3 Blade Hubs: PHC-C3YF-2

Blades: C7663-2R

Pitch Setting at 30 inch Station: Low 13.5°; Feathered
84.0°

Diameter: 76 inches, cut-off permitted to 74.5 inches

NOTE

Other propellers are approved and are listed in the FAA Aircraft Specification 3A16 or are approved by Supplemental Type Certificate.

FUEL

Aviation Gasoline 100LL (blue) preferred, 100 (green) minimum grade.

STANDARD SYSTEM (Main and Auxiliary):

Total Capacity	112 Gallons
Total Usable	106 Gallons

OPTIONAL SYSTEM (Main and Auxiliary):

Total Capacity	142 Gallons
Total Usable	136 Gallons

OIL

The oil capacity is 12 quarts for each engine.

WEIGHTS

95-B55 (TC-371, TC-502 thru TC-954)

Maximum Ramp Weight	5021 lbs
Maximum Take-Off Weight	5000 lbs
Maximum Landing Weight	5000 lbs

95-B55 (TC-955 thru TC-1607 and prior serials when modified by Kit 55-4014)

Maximum Ramp Weight	5121 lbs
Maximum Take-Off Weight	5100 lbs
Maximum Landing Weight	5100 lbs

Section I
General

BEEHCRAFT Baron B55
TC-371, TC-502 thru TC-1607

95-B55A

Maximum Ramp Weight	5011 lbs
Maximum Take-Off Weight	4990 lbs
Maximum Landing Weight	4990 lbs

CABIN AND ENTRY DIMENSIONS

Length	10 ft 1 in.
Height (Max.)	4 ft 2 in.
Width (Max.)	3 ft 6 in.
Entrance Door	37 in. x 36 in.

BAGGAGE SPACE AND ENTRY DIMENSIONS

Main Cabin Compartment	35 cu ft
Standard Aft Hatshelf	1.7 cu ft
Optional Extended Aft Compartment	10 cu ft
Standard Baggage Door	18.5 in. x 22.5 in.
Optional Baggage Door	38 in. x 22.5 in.
Nose Compartment	12 cu ft

SPECIFIC LOADINGS (5000 lbs)

Wing Loading	25.1 lbs/sq ft
Power Loading	9.6 lbs/hp

SPECIFIC LOADINGS (5100 lbs)

Wing Loading	25.6 lbs/sq ft
Power Loading	9.8 lbs/hp

**SYMBOLS, ABBREVIATIONS AND
TERMINOLOGY**

The following Abbreviations and Terminologies have been listed for convenience and ready interpretation where used within this handbook. Whenever possible, they have been categorized for ready reference.

AIRSPEED TERMINOLOGY

- CAS** Calibrated Airspeed is the indicated speed of an airplane, corrected for position and instrument error. Calibrated airspeed is equal to true airspeed in standard atmosphere at sea level.
- GS** Ground Speed is the speed of an airplane relative to the ground.
- IAS** Indicated Airspeed is the speed of an airplane as shown on the airspeed indicator when corrected for instrument error. IAS values published in this handbook assume zero instrument error.
- TAS** True Airspeed is the airspeed of an airplane relative to undisturbed air which is the CAS corrected for altitude, temperature, and compressibility.
- V_{MCA}** Air minimum control speed is the minimum flight speed at which the airplane is directionally controllable as determined in accordance with Federal Aviation Regulations. The airplane certification conditions include one engine becoming inoperative and windmilling; a 5° bank towards the operative engine; takeoff power on operative engine; landing gear up; flaps up; and most rearward C.G. For some conditions of weight and altitude, stall can be encountered at speeds above V_{MCA} as established by the certification procedure described above, in which event stall speed must be regarded as the limit of effective directional control.

- V_{SSE} The Intentional One-Engine-Inoperative Speed is a speed above both V_{MCA} and stall speed, selected to provide a margin of lateral and directional control when one engine is suddenly rendered inoperative. Intentional failing of one engine below this speed is not recommended.
- V_A Maneuvering Speed is the maximum speed at which application of full available aerodynamic control will not overstress the airplane.
- V_F Design flap speed is the highest speed permissible at which wing flaps may be actuated.
- V_{FE} Maximum Flap Extended Speed is the highest speed permissible with wing flaps in a prescribed extended position.
- V_{LE} Maximum Landing Gear Extended Speed is the maximum speed at which an airplane can be safely flown with the landing gear extended.
- V_{LO} Maximum Landing Gear Operating Speed is the maximum speed at which the landing gear can be safely extended or retracted.
- V_{NE} Never Exceed Speed is the speed limit that may not be exceeded at any time.
- V_{NO} or V_C Maximum Structural Cruising Speed is the speed that should not be exceeded except in smooth air and then only with caution.

- V_S Stalling Speed or the minimum steady flight speed at which the airplane is controllable.
- V_{SO} Stalling Speed or the minimum steady flight speed at which the airplane is controllable in the landing configuration.
- V_X Best Angle-of-Climb Speed is the airspeed which delivers the greatest gain of altitude in the shortest possible horizontal distance.
- V_Y Best Rate-of-Climb Speed is the airspeed which delivers the greatest gain in altitude in the shortest possible time.

METEOROLOGICAL TERMINOLOGY

- ISA** International Standard Atmosphere in which
- (1) The air is a dry perfect gas;
 - (2) The temperature at sea level is 15° Celsius (59° Fahrenheit);
 - (3) The pressure at sea level is 29.92 in. Hg (1013.2 millibars);
 - (4) The temperature gradient from sea level to the altitude at which the temperature is -56.5° C (-69.7° F) is -0.00198° C (-0.003566° F) per foot and zero above that altitude.
- OAT** Outside Air Temperature is the free air static temperature, obtained either from inflight temperature indications adjusted for instrument error and compressibility effects, or ground meteorological sources.

**Section I
General**

**BEECHCRAFT Baron B55
TC-371, TC-502 thru TC-1607**

Indicated Pressure Altitude	The number actually read from an altimeter when the barometric sub-scale has been set to 29.92 in. Hg (1013.2 millibars).
Pressure Altitude	Altitude measured from standard sea-level pressure (29.92 in. Hg) by a pressure or barometric altimeter. It is the indicated pressure altitude corrected for position and instrument error. In this Handbook, altimeter instrument errors are assumed to be zero. Position errors may be obtained from the Altimeter Correction Chart.
Station Pressure	Actual atmospheric pressure at field elevation.
Wind	The wind velocities recorded as variables on the charts of this handbook are to be understood as the headwind or tailwind components of the reported winds.

POWER TERMINOLOGY

Take-off and Maximum Continuous	The highest power rating not limited by time.
Cruise Climb	Power recommended for cruise climb.
Maximum Cruise	The highest power settings recommended for cruise.

Recommended Cruise	Intermediate power settings for which cruise power settings are presented.
Economy Cruise	The lowest power setting for which cruise power settings are presented.

ENGINE CONTROLS AND INSTRUMENTS TERMINOLOGY

Throttle Controls	The lever used to control the introduction of a fuel-air mixture into the intake passages of an engine.
Propeller Controls	This lever requests the governor to maintain rpm at a selected value and, in the maximum decrease rpm position, feathers the propellers.
Mixture Controls	This lever, in the idle cut-off position, stops the flow of fuel at the injectors and in the intermediate thru the full rich positions, regulates the fuel air mixture.
Propeller Governors	The governors maintain the selected rpm requested by the propeller control levers.
Manifold Pressure Gage	An instrument that measures the absolute pressure in the intake manifold of an engine, expressed in inches of mercury (in. Hg).
Tachometers	An instrument that indicates the rotational speed of the propeller (and engine) in revolutions per minute (rpm).

AIRPLANE PERFORMANCE AND
FLIGHT PLANNING TERMINOLOGY

Climb Gradient	The ratio of the change in height during a portion of a climb, to the horizontal distance traversed in the same time interval.
Demonstrated Crosswind Velocity	The demonstrated crosswind velocity is the velocity of the crosswind component for which adequate control of the airplane during take-off and landing was actually demonstrated during certification tests.
Accelerate-Stop Distance	The distance required to accelerate to a specified speed and, assuming failure of an engine at the instant that speed is attained, to bring the airplane to a stop.
Accelerate-Go Distance	The distance required to accelerate to a specified speed and, assuming failure of an engine at the instant that speed is attained, feather inoperative propeller and continue takeoff on the remaining engine to a height of 50 feet.
MEA	Minimum enroute IFR altitude.
Route Segment	A part of a route. Each end of that part is identified by: (1) a geographical location; or (2) a point at which a definite radio fix can be established.
GPH	U.S. Gallons per hour.

WEIGHT AND BALANCE TERMINOLOGY

Reference Datum	An imaginary vertical plane from which all horizontal distances are measured for balance purposes.
Station	A location along the airplane fuselage usually given in terms of distance from the reference datum.
Arm	The horizontal distance from the reference datum to the center of gravity (C.G.) of an item.
Moment	The product of the weight of an item multiplied by its arm. (Moment divided by a constant is used to simplify balance calculations by reducing the number of digits.)
Airplane Center of Gravity (C.G.)	The point at which an airplane would balance if suspended. Its distance from the reference datum is found by dividing the total moment by the total weight of the airplane.
C.G. Arm	The arm obtained by adding the airplane's individual moments and dividing the sum by the total weight.
C.G. Limits	The extreme center of gravity locations within which the airplane must be operated at a given weight.
Usable Fuel	Fuel available for flight planning.

**Section I
General**

**BEEHCRAFT Baron B55
TC-371, TC-502 thru TC-1607**

Unusable Fuel	Fuel remaining after a runout test has been completed in accordance with governmental regulations.
Standard Empty Weight	Weight of a standard airplane including unusable fuel, full operating fluids and full oil.
Basic Empty Weight	Standard empty weight plus optional equipment.
Payload	Weight of occupants, cargo and baggage.
Useful Load	Difference between ramp weight and basic empty weight.
Maximum Ramp Weight	Maximum weight approved for ground maneuvering. (It includes weight of start, taxi, and run up fuel).
Maximum Take-off Weight	Maximum weight approved for the start of the take off run.
Maximum Landing Weight	Maximum weight approved for the landing touchdown.
Zero Fuel Weight	Weight exclusive of usable fuel.

SECTION II

LIMITATIONS

TABLE OF CONTENTS

<i>SUBJECT</i>	<i>PAGE</i>
Airspeed Limitations	2-3
Airspeed Indicator Markings	2-4
Power Plant Limitations	2-5
Engines	2-5
Fuel	2-5
Oil	2-5
Propellers	2-5
Starters - Time for Cranking	2-7
Power Plant Instrument Markings	2-7
Oil Temperature	2-7
Oil Pressure	2-7
Fuel Pressure	2-7
Manifold Pressure	2-8
Tachometer	2-8
Cylinder Head Temperature	2-8
Miscellaneous Instrument Markings	2-8
Suction (Vacuum)	2-8
Propeller Deicer Ammeter	2-9
Surface Deice	2-9
Fuel Quantity	2-9
Weights	2-9
CG Limits	2-10
Maneuvers	2-11
Flight Load Factors	2-11
Minimum Flight Crew	2-11
Kinds of Operation	2-11
October 1978	2-1

TABLE OF CONTENTS (Continued)

<i>SUBJECT</i>	<i>PAGE</i>
Required Equipment for Various Conditions of Flight	2-12 - 2-21
Fuel	2-22
Fuel Management	2-22
Oxygen Requirements	2-23
Maximum Passenger Seating Configuration	2-23
Seating	2-23
Placards	2-24 - 2-34

**BEECHCRAFT Baron B55
TC-371, TC-502 thru TC-1607**

**Section II
Limitations**

The limitations included in this section have been approved by the Federal Aviation Administration.

The following limitations must be observed in the operation of this airplane.

AIRSPEED LIMITATIONS

SPEED	CAS		IAS		REMARKS
	KNOTS	MPH	KNOTS	MPH	
Never Exceed V_{NE}	223	257	224	258	Do not exceed this speed in any operation
Maximum Structural Cruising V_{NO} or V_C	182	210	183	211	Do not exceed this speed except in smooth air and then only with caution
Maneuvering V_A	156	180	157	181	Do not make full or abrupt control movements above this speed
Maximum Flap Extension/ Extended V_{FE} (Full down)	①113	130	113	130	Do not extend flaps or operate with flaps extended above this speed
(Full down)	②122	140	122	140	
Maximum Landing Gear Operating/ Extended V_{LO} and V_{LE}	③143 ③152	165 175	143 153	165 176	Do not extend, retract or operate with landing gear extended above this speed
Air Minimum Control Speed V_{MCA}	80	92	78	90	Minimum speed for directional controllability after sudden loss of engine

①TC-371, TC-502 thru TC-954.

②TC-955 thru TC-1607 and those prior serials having Kit 55-4014 installed.

③TC-371, TC-502 thru TC-1156.

④TC-1157 thru TC-1607.

*AIRSPEED INDICATOR MARKINGS

MARKING	CAS		IAS		SIGNIFICANCE
	KNOTS	MPH	KNOTS	MPH	
White Arc	①68-113 ②68-122	78-130 78-140	68-113 69-122	78-130 79-140	Full Flap Operating Range
Blue Radial	101	116	100	115	One-Engine-Inoperative Best Rate-of-Climb Speed
Green Arc	76-182	87-210	78-183	90-211	Normal Operating Range
Yellow Arc	182-223	210-257	183-224	211-258	Operate with caution only in smooth air
Red Radial	223	257	224	258	Maximum speed for ALL operations

*The Airspeed Indicator is marked in CAS values

①TC-371, TC-502 thru TC-954

②TC-955 thru TC-1607

POWER PLANT LIMITATIONS

ENGINES

Two Continental IO-470-L fuel injected, air cooled six-cylinder, horizontally-opposed engines each rated at 260 horsepower at 2625 rpm.

Take-off and Maximum

continuous power Full throttle, 2625 rpm

Maximum Cylinder Head Temperature 460°F
Maximum Oil Temperature 225°F
Minimum Take-off Oil Temperature 75°F
Minimum Oil Pressure (Idle) 30 psi
Maximum Oil Pressure 80 psi

FUEL

Aviation Gasoline 100LL (blue) preferred, 100 (green) minimum grade.

OIL

Ashless dispersant oils must meet Continental Motors Corporation Specification MHS-24B. Refer to APPROVED ENGINE OILS, Servicing Section.

PROPELLERS

Propeller hubs and blades shall be identical on both engines.

McCAULEY

2 Blade Hubs: 2AF34C55

Blades: 78FF-0

Pitch Setting at 30 inch Station: Low 15°; high 79°

Diameter: Maximum 78 inches, minimum 76 inches

**Section II
Limitations**

**BEEHCRAFT Baron B55
TC-371, TC-502 thru TC-1607**

HARTZELL

2 Blade Hubs: BHC-C2YF-2CHF

Blades: FC8465-6

Pitch Setting at 30 inch Station: Low 16.0°;

Feathered 80.0°

Diameter: 78 inches, cut-off permitted to 76.5 inches

or

2 Blade Hubs: BHC-C2YF-2CH

Blades: C8465-6

Pitch Setting at 30 inch Station: Low 16.0°;

Feathered 80.0°

Diameter: 78 inches, cut-off permitted to 76.5 inches

OR

3 Blade Hubs: PHC-A3VF-2B

Blades: V7636D

Pitch Setting at 30 inch Station:

Low 13.0° to 13.5°; High 84.0° to 86.0°

Diameter: Maximum 76.25 inches, No cut-off permitted

or

3 Blade Hubs: PHC-A3XF-2B

Blades: 7636D

Pitch Setting at 30 inch Station:

Low 13.0° to 13.5°; High 84.0° to 86.0°

Diameter: Maximum 76.25 inches, No cut-off permitted

OR

3 Blade Hubs: PHC-C3YF-2F

Blades: FC7663-2R

Pitch Setting at 30 inch Station: Low 13.5°; Feathered
84.0°

Diameter: 76 inches, cut-off permitted to 74.5 inches

or

3 Blade Hubs: PHC-C3YF-2

Blades: C7663-2R

Pitch Setting at 30 inch Station: Low 13.5°; Feathered 84.0°

Diameter: 76 inches, cut-off permitted to 74.5 inches

NOTE

Other propellers are approved and are listed in the FAA Aircraft Specification 3A16 or are approved by Supplemental Type Certificate.

STARTERS - TIME FOR CRANKING

Do not operate starter continuously for more than 30 seconds. Allow starter to cool before cranking again.

POWER PLANT INSTRUMENT MARKINGS

OIL TEMPERATURE

Caution (Yellow Radial) 75°F
Operating Range
(Green Arc) 75° to 225°F
Maximum (Red Radial) 225°F

OIL PRESSURE

Minimum Pressure (Red Radial) 30 psi
Operating Range (Green Arc) 30 to 60 psi
Maximum Pressure (Red Radial) 80 psi

FUEL PRESSURE

Minimum (Red Radial) 1.5 psi
Operating Range
(Green Arc) 5 to 17 psi
Cruise Power
(Heavy Green Arc) 5 to 9.5 psi
Maximum (Red Radial) 17.5 psi

Section II
Limitations

BEECHCRAFT Baron B55
TC-371, TC-502 thru TC-1607

MANIFOLD PRESSURE

Operating Range
(Green Arc) 15 to 29.6 in. Hg
Maximum (Red Radial) 29.6 in. Hg

TACHOMETER

Operating Range (Green Arc) ... 2000 to 2625 rpm
Maximum (Red Radial) 2625 rpm

CYLINDER HEAD TEMPERATURE

Operating Range
(Green Arc) 200° to 460°F
Maximum Temperature
(Red Radial) 460°F

MISCELLANEOUS INSTRUMENT MARKINGS

SUCTION (VACUUM)

Minimum (Red Radial) 3.75 in. Hg
Caution (Yellow Arc) 3.75 to 4.8 in. Hg
Normal (Green Arc) 4.8 to 5.25 in. Hg
Maximum (Red Radial) 5.25 in. Hg

or

Minimum (Red Radial) 3.75 in. Hg
Normal (Green Arc) 3.75 to 5.25 in. Hg
Maximum (Red Radial) 5.25 in. Hg
Red Button Source Failure Indicators

or

Operating Range (Green Arc) 4.3 to 5.9 in. Hg
Red Button Source Failure Indicators

PROPELLER DEICE AMMETER

Normal Operating Range
(Green Arc) 7 to 12 amps (2 blade)
Normal Operating Range
(Green Arc) 14 to 18 amps (3 blade)

SURFACE DEICE

Normal Operating Range
(Green Arc) 9 to 20 psi
Red Line 9 and 20 psi

FUEL QUANTITY

Yellow Arc (22-Gal Main Tank) E to 1/2 Full
Yellow Arc (37-Gal Main Tank) E to 1/4 Full

WEIGHTS

95-B55 (TC-371, TC-502 thru TC-954)
Maximum Ramp Weight 5021 lbs
Maximum Take-Off Weight 5000 lbs
Maximum Landing Weight 5000 lbs

95-B55 (TC-955 thru TC-1607 and prior serials when
modified by Kit 55-4014)
Maximum Ramp Weight 5121 lbs
Maximum Take-Off Weight 5100 lbs
Maximum Landing Weight 5100 lbs

95-B55A
Maximum Ramp Weight 5011 lbs
Maximum Take-Off Weight 4990 lbs
Maximum Landing Weight 4990 lbs

(weights continued pg. 2-10)

Section II
Limitations

BEEHCRAFT Baron B55
TC-371, TC-502 thru TC-1607

Maximum Baggage/Cargo Compartment Weights:

Main Cabin Compartment (less occupants and equipment)	400 lbs
Extended Aft Compartment	120 lbs
Nose Compartment (baggage less equipment) (TC-371, TC-502 thru TC-954)	270 lbs
Nose Compartment (baggage less equipment) (TC-955 thru TC-1607)	300 lbs

Refer to Weight and Balance section for additional information.

CG LIMITS

Baron 95-B55 (TC-371, TC-502 thru TC-954)

Forward Limits: 74 inches aft of datum at 3800 lbs and under, then straight line variation to 80.0 inches aft of datum at gross weight of 5000 lbs.

Aft Limits: 86 inches aft of datum at all weights.

Baron 95-B55A (TC-502 thru TC-954)

Forward Limits: 74 inches aft of datum at 3800 lbs and under, then straight line variation to 80.0 inches aft of datum at gross weight of 4990 lbs.

Aft Limits: 86 inches aft of datum at all weights.

Baron 95-B55 (TC-955 thru TC-1607 and prior serials when modified by Kit 55-4014)

Forward Limits: 74 inches aft of datum at 3800 lbs and under, then straight line variation to 77.5 inches aft of datum at 4740 lbs, then straight line variation to 81.0 inches aft of datum at gross weight of 5100 lbs.

Aft Limits: 86 inches aft of datum at all weights.

Baron 95-B55A (TC-955 thru TC-1607)

Forward Limits: 74 inches aft of datum at 3800 lbs and under, then straight line variation to 77.5 inches aft of datum at 4740 lbs, then straight line variation to 79.9 inches aft of datum at gross weight of 4990 lbs.

Aft Limits: 86 inches aft of datum at all weights.

Datum is 83.1 inches forward of center line through forward jack points.

MAC leading edge is 67.2 inches aft of datum.
MAC length is 63.1 inches.

MANEUVERS

This is a normal category airplane. Acrobatic maneuvers, including spins, are prohibited.

FLIGHT LOAD FACTORS

Positive maneuvering load factors:

Flaps Up 4.4G

Negative maneuvering load factor:

Flaps Up 3.0G

MINIMUM FLIGHT CREW One pilot

KINDS OF OPERATION

This airplane is approved for the following type operations when the required equipment is installed and operational as defined herein:

1. VFR day and night
2. IFR day and night

**REQUIRED EQUIPMENT FOR VARIOUS
CONDITIONS OF FLIGHT**

Federal Aviation Regulations 91.3(a), 91.24, 91.25, 91.32, 91.33, 91.52, 91.90, 91.97, 91.170) specify the minimum numbers and types of airplane instruments and equipment which must be installed and operable for various kinds of flight conditions. This includes VFR day, VFR night, IFR day, and IFR night.

Regulations also require that all airplanes be certificated by the manufacturer for operations under various flight conditions. At certification, all required equipment must be in operating condition and should be maintained to assure continued airworthiness. If deviations from the installed equipment were not permitted, or if the operating rules did not provide for various flight conditions, the airplane could not be flown unless all equipment was operable. With appropriate limitations, the operation of every system or component installed in the airplane is not necessary, when the remaining operative instruments and equipment provide for continued safe operation. Operation in accordance with limitations established to maintain airworthiness, can permit continued or uninterrupted operation of the airplane temporarily.

For the sake of brevity, the Required Equipment Listing does not include obviously required items such as wings, rudders, flaps, engine, landing gear, etc. Also the list does not include items which do not affect the airworthiness of the airplane such as galley equipment, entertainment systems, passenger convenience items, etc. However, it is important to note that **ALL ITEMS WHICH ARE RELATED TO THE AIRWORTHINESS OF THE AIRPLANE AND NOT INCLUDED ON THE LIST ARE AUTOMATICALLY REQUIRED TO BE OPERATIVE.**

To enable the pilot to rapidly determine the FAA equipment requirements necessary for a flight into specific conditions, the following equipment requirements and exceptions are presented. It is the final responsibility of the pilot to determine whether the lack of, or inoperative status of a piece of equipment on his airplane, will limit the conditions under which he may operate the airplane.

WARNING

Ice protection equipment which may be installed on this airplane has not been demonstrated to meet requirements for flight into known icing conditions.

LEGEND

- (-) Indicates that the item may be inoperative for the specified condition.
- (*) Refers to the REMARKS AND/OR EXCEPTIONS column for explicit information or reference.

Section II
Limitations

BEECHCRAFT Baron B55
TC-371, TC-502 thru TC-1607

SYSTEM and/or COMPONENT	Number Installed				Remarks and/or Exceptions
	VFR Day		VFR Night		
	IFR Day	IFR Night	IFR Day	IFR Night	
GENERAL					
Overwater flight	*	*	*	*	-*Per FAR 91.33
ATA 100 CHAPTER 23 COMMUNICATIONS					
VHF communications system	*	*	*	*	-*Per FAR 91.33
ATA 100 CHAPTER 24 ELECTRICAL POWER					
Battery	1	1	1	1	-
DC alternator/generator	2	2	2	2	-
DC loadmeter	2	2	2	2	-

ATA 100 CHAPTER 25 EQUIPMENT AND FURNISHING	*	*	*	*	*			
Seat belts and shoulder harness								* Per FAR 91.33, all seats
Emergency locator trans- mitter	1	1	1	1	1			- Per FAR 91.52
ATA 100 CHAPTER 26 FIRE PROTECTION								
Portable fire extinguisher	*	*	*	*	*			-*Optional
ATA 100 CHAPTER 27 FLIGHT CONTROLS								
Trim tab indicators - Rudder aileron, and elevator	3	3	3	3	3			- May be inoperative providing that tabs are visually checked in the neutral position prior to take-off and checked for full range of operation.
Flap position indicator (TC-371, 502 thru 1010) (TC-1011 and after)	2	2	2	2	2			- May be inoperative providing flap travel is visually inspected prior to take-off.
Stall warning	1	1	1	1	1			
	1	1	1	1	1			

**Section II
Limitations**

**BEECHCRAFT Baron B55
TC-371, TC-502 thru TC-1607**

SYSTEM and/or COMPONENT	Number Installed				Remarks and/or Exceptions
	VFR Day				
	VFR Night	IFR Day	IFR Night		
ATA 100 CHAPTER 28 FUEL EQUIPMENT					
Engine driven fuel pump	2	2	2	2	-
Fuel boost pump	2	2	2	2	-
Fuel quantity indicator	2	2	2	2	- One may be inoperative providing other side is operational and amount of fuel on board can be established to be adequate for the intended flight.
Fuel quantity indicator selector switch	1	1	1	1	- May be inoperative provided main quantity indicators are operating.
Fuel pressure indicator	1	1	1	1	- Dual indicating

<p>ATA 100 CHAPTER 30 ICE AND RAIN PROTECTION</p>	<p>1</p>	<p>-</p>	<p>-</p>	<p>1</p>	<p>1</p>	<p>-</p>
<p>Alternate static air source</p>	<p>1(2)</p>	<p>-</p>	<p>-</p>	<p>1</p>	<p>1</p>	<p>-</p>
<p>Pitot heater</p>						
<p>ATA 100 CHAPTER 32 LANDING GEAR</p>						
<p>Landing gear motor</p>	<p>1</p>	<p>1</p>	<p>1</p>	<p>1</p>	<p>1</p>	<p>-</p>
<p>Landing gear position indication lights</p>	<p>2</p>	<p>2</p>	<p>2</p>	<p>2</p>	<p>2</p>	<p>-</p>
<p>Landing gear aural warning horn</p>	<p>1</p>	<p>1</p>	<p>1</p>	<p>1</p>	<p>1</p>	<p>-</p>

- May be inoperative provided operations are continued only to a point where repairs can be accomplished.

Section II
Limitations

BEECHCRAFT Baron B55
TC-371, TC-502 thru TC-1607

SYSTEM and/or COMPONENT	Number Installed			Remarks and/or Exceptions
	VFR Day	VFR Night	IFR Day	
ATA 100 CHAPTER 33 LIGHTS				
Cockpit and instrument lights	*	-	*	- *Lights must illuminate all instruments and controls.
Taxi light	1	-	-	
Landing light	2	*	*	- *Per FAR 91.33
Rotating beacon	1(2)	-	1	- Top beacon must be operative
Position light	3	-	3	

ATA 100 CHAPTER 34 NAVIGATION INSTRUMENTS										
Altimeter	1	1	1	1	1	1	1	1	-	
Airspeed indicator	1	1	1	1	1	1	1	1	-	
Vertical speed	1	-	-	-	-	-	-	-	-	
Magnetic compass	1	1	1	1	1	1	1	1	-	
Attitude indicator	1	-	-	-	-	-	-	-	-	
Turn and slip indicator	1	-	-	-	-	-	-	-	-	
Directional gyro	1	-	-	-	-	-	-	-	-	
Clock	1	-	-	-	-	-	-	-	-	
Transponder	*	*	*	*	*	*	*	*	*	-*Per FAR 91.24, 91.90, 91.97
Distance measuring equipment	*	*	*	*	*	*	*	*	*	-*Per FAR 91.33
Navigation equipment	*	-	-	-	-	-	-	-	*	-*Per FAR 91.33
ATA 100 CHAPTER 35 OXYGEN										
Oxygen system	-	*	*	*	*	*	*	*	*	-*Per FAR 91.32

Section II
Limitations

BEECHCRAFT Baron B55
TC-371, TC-502 thru TC-1607

SYSTEM and/or COMPONENT	Number Installed			Remarks and/or Exceptions
	VFR Day	VFR Night	IFR Day	
			IFR Night	
ATA 100 CHAPTER 37 VACUUM				
Instrument air source	2	2	2	-
Instrument air indicator	1	1	1	- Dual indicating
Deicing pressure indicator	*	*	*	- *One required with optional sur-face deice installation.
ATA 100 CHAPTER 77 ENGINE INDICAT- ING INSTRUMENTS				
Engine tachometer	1	1	1	- Dual indicating
Manifold pressure indicators	1	1	1	- Dual indicating
Cylinder head temp gage	2	2	2	-

ATA 100 CHAPTER 79 ENGINE OIL INSTRUMENTS	Oil pressure indicator	2	2	2	2	2	2	2	-	-
	Oil temperature indicator	2	2	2	2	2	2	2	-	-

**Section II
Limitations**

**BEECHCRAFT Baron B55
TC-371, TC-502 thru TC-1607**

FUEL

TOTAL FUEL with left and right main and auxiliary fuel systems full:

Standard Fuel System

Capacity	112 Gallons
Usable	106 Gallons

Optional Fuel System

Capacity	142 Gallons
Usable	136 Gallons

FUEL MANAGEMENT

Takeoff and land on main fuel tanks only. When operating fuel selector, feel for detent position.

Do not take off if Fuel Quantity Gages indicate in Yellow Arc or with less than 13 gallons in each main tank.

The fuel crossfeed system to be used during emergency conditions in level flight only.

Turning type takeoffs or takeoffs immediately following fast taxi turns are prohibited if the airplane is not equipped with two baffled leading edge fuel tanks or a fuel reservoir in each leading edge fuel tank or a combination of the two.

Maximum slip or skid duration:

20 seconds for airplanes with unbaffled main fuel tanks or without reservoirs in either wing.

30 seconds for airplanes with baffled main fuel tanks or reservoirs in both wings.

OXYGEN REQUIREMENTS

Refer to FAR 91.32 for oxygen requirements.

**MAXIMUM PASSENGER SEATING
CONFIGURATION**

Five (5) passengers and one (1) pilot

SEATING

All seats must be in the upright position for takeoff and landing.

**Section II
Limitations**

**BEECHCRAFT Baron B55
TC-371, TC-502 thru TC-1607**

PLACARDS

***Below Ignition Switch Panel: (CAS)
(TC-371, TC-502 thru TC-954)***

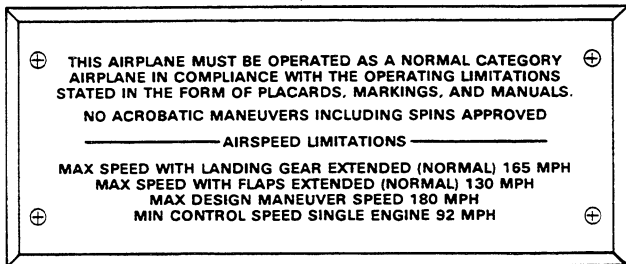

***Below Ignition Switch Panel: (CAS)
(TC-955 thru TC-1156 and prior serials when modified by
Kit 55-4014)***

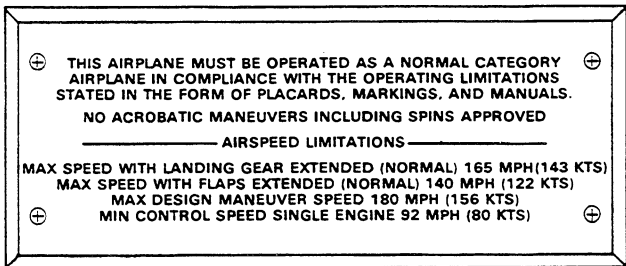

***Below Ignition Switch Panel: (CAS)
(TC-1157 thru TC-1607)***

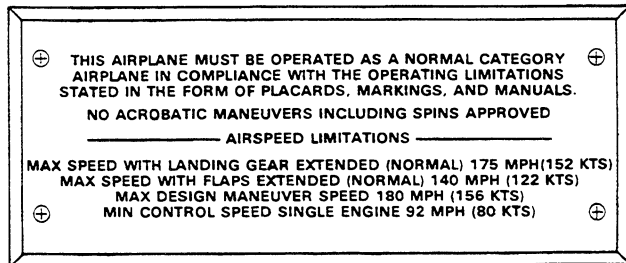

**Temporary Change
to the
Pilot's Operating Handbook
and
FAA Approved Airplane Flight Manual
P/N 96-590011-25TC1**

Publication Affected	95-B55 Pilot's Operating Handbook and FAA Approved Airplane Flight Manual (P/N 96-590011-25, Issued October, 1978 or Subsequent)
Airplane Serial Numbers Affected	TE-371,TC-502 thru TC-1607 (Includes Gr. Wt. Kit 55-4014)
Description of Change	The addition of a placard to the fuel selectors to warn of the no-flow condition that exists between the fuel selector detents.
Filing Instructions	Insert this temporary change into the 95-B55 Pilot's Operating Handbook and FAA Approved Airplane Flight Manual immediately following page 2-24 (Section II, LIMITATIONS) and retain until rescinded or replaced.

LIMITATIONS

PLACARDS

Located On The Face Of The Fuel Selector Valves, For Those Airplanes In Compliance With S.B. 2670:

**WARNING - POSITION SELECTORS IN DETENTS ONLY -
NO FUEL FLOW TO ENGINES BETWEEN DETENTS**

Approved:



A.C. Jackson
Raytheon Aircraft Company
DOA CE-2

Below Limitations Placard When Airplane Is Equipped With Strobe Lights:

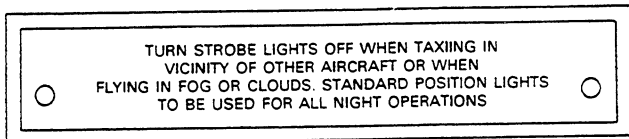

Between Fuel Selector Handles:
STANDARD 106 GALLON FUEL SYSTEM



Between Fuel Selector Handles:
OPTIONAL 136 GALLON FUEL SYSTEM



Section II
Limitations

BEEHCRAFT Baron B55
TC-371, TC-502 thru TC-1607

PLACARDS (Cont'd)

*On the Lower Portion of the Floating Instrument Panel:
This Placard is Installed Only When the Airplane is Not
Equipped With Two Baffled Leading Edge Fuel Tanks or a
Fuel Reservoir in Each Leading Edge Fuel Tank or a Baffled
Leading Edge Fuel Tank on One Side and a Reservoir
Installed in the Leading Edge Tank on the Other Side.*

**TAKE OFF AND LAND ON MAIN TANKS ONLY.
TURNING TYPE TAKEOFFS OR TAKEOFFS IMMEDIATELY
FOLLOWING FAST TAXI TURNS PROHIBITED. REFER
TO FAA FLIGHT MANUAL FOR OTHER FUEL SYSTEM
LIMITATIONS**

*On Top of Front Spar Cover Assy:
(TC-1299 thru TC-1382 - STANDARD FUEL SYSTEM)*

⊕ TAKEOFF & LAND ON MAIN TANKS ONLY. TURNING TYPE TAKEOFFS OR
TAKEOFFS IMMEDIATELY FOLLOWING A FAST TAXI TURN PROHIBITED.
REFER TO FAA FLIGHT MANUAL FOR OTHER FUEL SYSTEM LIMITATIONS. ⊕

*On the Floating Instrument Panel:
(TC-371, TC-502 thru TC-1382 - STANDARD FUEL
SYSTEM)*

*(TC-371, TC-502 thru TC-1243 - OPTIONAL FUEL
SYSTEM)*

**DO NOT TAKE OFF IF FUEL QUANTITY GAGES
INDICATE IN YELLOW ARC OR WITH LESS
THAN 13 GALLONS IN EACH MAIN TANK**

*On Top of the Front Spar Cover Assy:
(TC-1383 thru TC-1607 - STANDARD FUEL SYSTEM)
(TC-1244 thru TC-1607 - OPTIONAL FUEL SYSTEM)*

⊕ DO NOT TAKE OFF IF FUEL QUANTITY GAGES INDICATE IN YELLOW
ARC OR WITH LESS THAN 13 GALLONS IN EACH MAIN TANK ⊕

*On Lower Sidewall Adjacent To Pilot:
(TC-371, TC-502 thru TC-875, TC-877, TC-879, TC-882
thru TC-897 - OPTIONAL)*

EMERGENCY AIRSPEED STATIC SOURCE

WARNING

**CLOSE STORM WINDOW
SEE FLIGHT MANUAL EMERGENCY
PROCEDURES FOR AIRSPEED-
ALTIMETER CALIBRATION ERROR**

*On Lower Sidewall Adjacent To Pilot:
(TC-876, TC-878, TC-880, TC-881, TC-898 thru TC-954 -
OPTIONAL, TC-955 thru TC-1372 - STANDARD)*

WARNING

EMERGENCY AIRSPEED STATIC SOURCE

**SEE FLIGHT MANUAL
EMERGENCY PROCEDURES
FOR AIRSPEED ALTIMETER
CALIBRATION ERROR**

**ON
EMERGENCY**

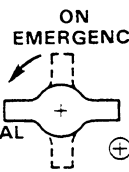

**OFF
NORMAL**

OR

WARNING

EMERGENCY AIRSPEED STATIC SOURCE

**ON
EMERGENCY**

**SEE PILOTS CHECK LIST
OR FLIGHT MANUAL
EMERGENCY PROCEDURES
FOR AIRSPEED & ALTIMETER
CALIBRATION ERROR**



**OFF
NORMAL**

Section II
Limitations

BEECHCRAFT Baron B55
TC-371, TC-502 thru TC-1607

PLACARDS (Cont'd)

On Lower Sidewall Adjacent To Pilot:
(TC-1373 thru TC-1402 - STANDARD)
(TC-1403 thru TC-1607 - OPTIONAL)

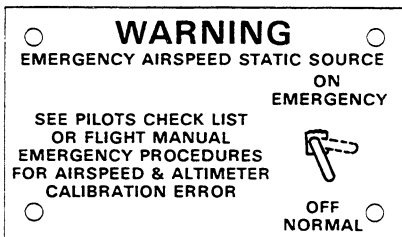

On Lower Sidewall Adjacent To Pilot:
(TC-1403 thru TC-1607 - STANDARD)

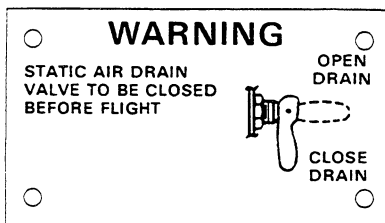

On Fuel Selector Panel:

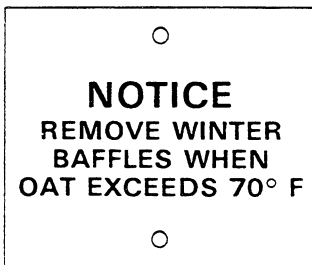

*On Pilot's Storm Window: (CAS)
(TC-371, TC-502 thru TC-1402)*

CAUTION
**DO NOT OPEN ABOVE
145 MPH (126 KNOTS)**

On Middle Windows:

**DO NOT OPEN
IN FLIGHT**

**LATCH WINDOW
BEFORE TAKE-OFF**

*On Windows Adjacent To Pilot's and Co-Pilot's Seat:
(TC-1449 thru TC-1607 when shoulder harness installed)*

**WHEN SHOULDER HARNESS
IS IN USE, SNUG LAP BELT
WITH BUCKLE CENTERED IN
FRONT OF OCCUPANT WITH
SEAT BACK UPRIGHT**

PLACARDS (Cont'd)

Below Left and Right Middle Windows after compliance with BEEHCRAFT Service Instructions 1241:

**EMERGENCY EXIT
LIFT LATCH - PULL PIN
PUSH WINDOW OUT**

On Top of Front Spar Carry-Thru Structure Between Front Seats:

**EMERGENCY
LANDING GEAR
INSTRUCTIONS
TO EXTEND**

ENGAGE HANDLE IN REAR
OF FRONT SEAT AND TURN
COUNTERCLOCKWISE AS FAR
AS POSSIBLE (50 TURNS)

On Instrument Panel When Anti-Collision Lights Are Not Installed:

**THIS AIRCRAFT NOT FULLY
EQUIPPED FOR NIGHT FLIGHT**

Adjacent to Cabin Door Handle:

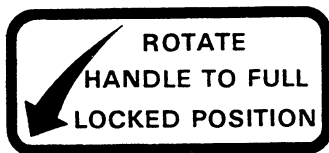

On Hat Shelf:



*On Inside Of Rear Baggage Compartment Door:
Standard Baggage Compartment*

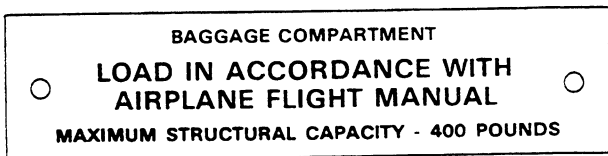

*On Inside Of Rear Baggage Compartment Door:
Optional Extended Baggage Compartment*

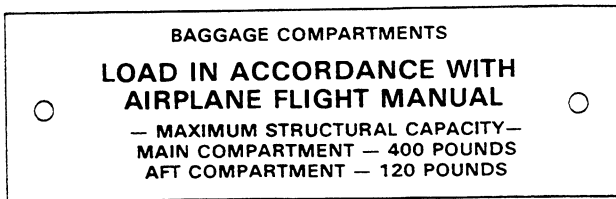

Section II
Limitations

BEEHCRAFT Baron B55
TC-371, TC-502 thru TC-1607

PLACARDS (Cont'd)

In Plain View When Nose Baggage Compartment Door Is Open

(TC-371, TC-502 thru TC-954)

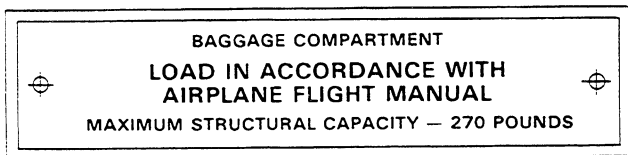

(TC-955 thru TC-1607)

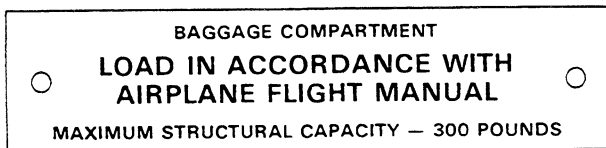

On Oxygen Console:

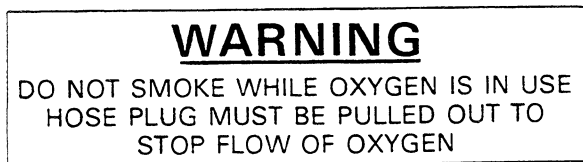

**BEECHCRAFT Baron B55
TC-371, TC-502 thru TC-1607**

**Section II
Limitations**

*At Each Passenger Oxygen Outlet:
(TC-371, TC-502 thru TC-1014)*

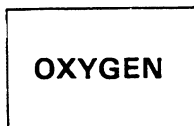

*At Each Passenger Oxygen Outlet:
(TC-1015 thru TC-1607)*

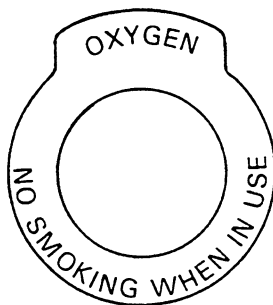

*At Pilot Oxygen Outlet:
(TC-371, TC-502 thru TC-1029)*

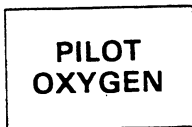

Section II
Limitations

BEECHCRAFT Baron B55
TC-371, TC-502 thru TC-1607

PLACARDS (Cont'd)

*At Pilot Oxygen Outlet:
(TC-1030 thru TC-1607)*

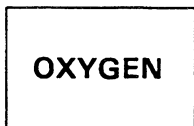

OR

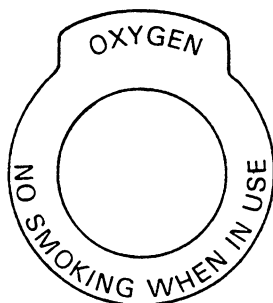

*At Co-Pilot Oxygen Outlet:
(TC-371, TC-502 thru TC-1014)*

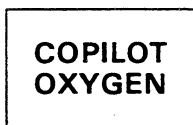

*At Co-Pilot Oxygen Outlet:
(TC-1015 thru TC-1607)*

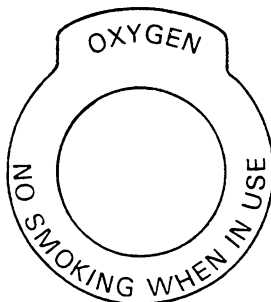

*On Oxygen Mask Stowage Container:
(TC-1288 thru TC-1607)*



SECTION III

EMERGENCY PROCEDURES

TABLE OF CONTENTS

<i>SUBJECT</i>	<i>PAGE</i>
Emergency Airspeeds	3-3
One Engine Operation	3-3
Determining Inoperative Engine	3-4
One-Engine Inoperative Procedures	3-4
Engine Failure During Take-Off	3-4
Engine Failure After Lift-off and In Flight	3-5
Air Start	3-6
Engine Fire	
On The Ground	3-7
In Flight	3-7
Emergency Descent	3-7
Glide	3-8
Landing Emergencies	3-8
Gear Up Landing	3-8
One-Engine Inoperative Landing	3-9
One-Engine Inoperative Go-Around	3-9
Systems Emergencies	3-10
One-Engine Inoperative Operation on Crossfeed	3-10
Electrical Smoke or Fire	3-10
Illumination of Overvoltage Light or Alternator-Out Light	3-11
Landing Gear Manual Extension	3-12

Section III **BEEHCRAFT Baron B55**
Emergency Procedures TC-371, TC-502 thru TC-1607

TABLE OF CONTENTS (Continued)

<i>SUBJECT</i>	<i>PAGE</i>
Landing Gear Retraction After Practice Manual Extension	3-13
Ice Protection	3-13
Surface Deice System	3-13
Electrothermal Propeller Deice System	3-13
Emergency Static Air Source System	3-15
Emergency Exits	3-16
Unlatched Door in Flight	3-16
Simulated One-Engine Inoperative	3-16
Spins	3-17

BEECHCRAFT Baron B55 **Section III**
TC-371, TC-502 thru TC-1607 **Emergency Procedures**

All airspeeds quoted in this section are indicated airspeeds (IAS) and assume zero instrument error.

EMERGENCY AIRSPEEDS (5100 LBS)

One-Engine-Inoperative Best	
Angle-of-Climb (V_X)	91 kts/105 mph
One-Engine-Inoperative Best	
Rate-of-Climb (V_Y)	100 kts/115 mph
Air Minimum Control Speed (V_{MCA})	78 kts/90 mph
One-Engine-Inoperative Enroute	
Climb	100 kts/115 mph
Emergency Descent	153 kts/176 mph
One-Engine-Inoperative Landing:	
Maneuvering to Final Approach	100 kts/115 mph
Final Approach (Flaps Down)	90 kts/104 mph
Intentional One-Engine-Inoperative	
Speed (V_{SSE})	84 kts/97 mph
Maximum Glide Range	120 kts/138 mph

The stall warning horn is inoperative when the battery and generator/alternator switches are turned off.

The following information is presented to enable the pilot to form, in advance, a definite plan of action for coping with the most probable emergency situations which could occur in the operation of the airplane. Where practicable, the emergencies requiring immediate corrective action are treated in check list form for easy reference and familiarization. Other situations, in which more time is usually permitted to decide on and execute a plan of action, are discussed at some length. In order to supply one safe speed for each type of emergency situation, the airspeeds presented were derived at 5100 lbs.

ONE ENGINE OPERATION

Two major factors govern one engine operations; airspeed and directional control. The airplane can be safely maneu-

Section III **BEEHCRAFT Baron B55**
Emergency Procedures TC-371, TC-502 thru TC-1607

vered or trimmed for normal hands-off operation and sustained in this configuration by the operative engine AS LONG AS SUFFICIENT AIRSPEED IS MAINTAINED.

DETERMINING INOPERATIVE ENGINE

The following checks will help determine which engine has failed.

1. **DEAD FOOT - DEAD ENGINE.** The rudder pressure required to maintain directional control will be on the side of the good engine.
2. **THROTTLE.** Partially retard the throttle for the engine that is believed to be inoperative; there should be no change in control pressures or in the sound of the engine if the correct throttle has been selected. **AT LOW ALTITUDE AND AIRSPEED THIS CHECK MUST BE ACCOMPLISHED WITH EXTREME CAUTION.**

Do not attempt to determine the inoperative engine by means of the tachometers or the manifold pressure gages. These instruments often indicate near normal readings.

ONE-ENGINE INOPERATIVE PROCEDURES

ENGINE FAILURE DURING TAKE-OFF

1. Throttle - **CLOSED**
2. Braking - **MAXIMUM**

If insufficient runway remains for stopping:

3. Fuel Selector Valves - **OFF**
4. Battery, Generator/Alternator, and Magneto/Start Switches - **OFF**

**ENGINE FAILURE AFTER LIFT-OFF
AND IN FLIGHT**

An immediate landing is advisable regardless of take-off weight. Continued flight cannot be assured if take-off weight exceeds the weight determined from the TAKE-OFF WEIGHT graph. Higher take-off weights will result in a loss of altitude while retracting the landing gear and feathering the propeller. Continued flight requires immediate pilot response to the following procedures.

1. Landing Gear and Flaps - UP
2. Throttle (inoperative engine) - CLOSED
3. Propeller (inoperative engine) - FEATHER
4. Power (operative engine) - AS REQUIRED
5. Airspeed - MAINTAIN SPEED AT ENGINE FAILURE (100 KTS (115 MPH) MAX.) UNTIL OBSTACLES ARE CLEARED

After positive control of the airplane is established:

6. Secure inoperative engine:
 - a. Mixture Control - IDLE CUT-OFF
 - b. Fuel Selector - OFF
 - c. Fuel Boost Pump - OFF
 - d. Magneto/Start Switch - OFF
 - e. Generator/Alternator Switch - OFF
 - f. Cowl Flap - CLOSED
7. Electrical Load - MONITOR (Maximum load of 1.0 on remaining engine)

NOTE

The most important aspect of engine failure is the necessity to maintain lateral and directional control. If airspeed is below 78 kts (90 mph), reduce power on the operative engine as required to maintain control.

AIR START

CAUTION

The pilot should determine the reason for engine failure before attempting an air start.

1. Fuel Selector Valve - MAIN OR AUXILIARY
2. Throttle - SET approximately 1/4 travel
3. Mixture Control - FULL RICH, below 5000 ft (1/2 travel above 5,000 ft)
4. Fuel Boost Pump - LOW
5. Magnetos - CHECK ON
6. Propeller:

WITH UNFEATHERING ACCUMULATORS:

- a. Move propeller control full forward to accomplish unfeathering. Use starter momentarily if necessary.
- b. Return control to high pitch (low rpm) position, when windmilling starts, to avoid overspeed.

If propeller does not unfeather or engine does not turn, proceed to WITHOUT UNFEATHERING ACCUMULATORS procedure.

WITHOUT UNFEATHERING ACCUMULATORS:

- a. Move propeller control forward of the feathering detent to midrange
 - b. Engage Starter to accomplish unfeathering
 - c. If engine fails to run, clear engine by allowing it to windmill with mixture in IDLE CUT-OFF. When engine fires, advance mixture to FULL RICH
7. When Engine Starts - ADJUST THROTTLE, PROPELLER and MIXTURE CONTROLS
 8. Fuel Boost Pump - OFF (when reliable power has been regained)

BEEHCRAFT Baron B55 **Section III**
TC-371, TC-502 thru TC-1607 **Emergency Procedures**

9. Generator/Alternator Switch - ON
10. Oil Pressure - CHECK
11. Warm Up Engine (approximately 2000 rpm and 15 in. Hg)
12. Set power as required and trim

ENGINE FIRE

ON THE GROUND

1. Mixture Controls - IDLE CUT-OFF
2. Continue to crank affected engine
3. Fuel Selector Valves - OFF
4. Battery and Generator/Alternator Switches - OFF
5. Extinguish with Fire Extinguisher

IN FLIGHT

Shut down the affected engine according to the following procedure and land immediately. Follow the applicable single-engine procedures in this section.

1. Fuel Selector Valve - OFF
2. Mixture Control - IDLE CUT-OFF
3. Propeller - FEATHERED
4. Fuel Boost Pump - OFF
5. Magneto/Start Switch - OFF
6. Generator/Alternator Switch - OFF

EMERGENCY DESCENT

1. Propellers - 2625 RPM
2. Throttles - CLOSED
3. Airspeed - 153 kts (176 mph)
4. Landing Gear - DOWN
5. Flaps - 10°

GLIDE

1. Propellers - FEATHER
2. Flaps - UP
3. Landing Gear - UP
4. Cowl Flaps - CLOSED

The glide ratio in this configuration is approximately 2 nautical miles of gliding distance for each 1000 feet of altitude above the terrain at an airspeed of 120 kts (138 mph).

LANDING EMERGENCIES

GEAR-UP LANDING

If possible, choose firm sod or foamed runway. When assured of reaching landing site:

1. Cowl Flaps - CLOSED
2. Wing Flaps - AS DESIRED
3. Throttles - CLOSED
4. Fuel Selector Valves - OFF
5. Mixture Controls - IDLE CUT-OFF
6. Battery, Generator/Alternator and Magneto/Start Switches - OFF
7. Keep wings level during touchdown.
8. Get clear of the airplane as soon as possible after it stops.

NOTE

The gear up landing procedures are based on the best available information and no actual tests have been conducted.

ONE ENGINE INOPERATIVE LANDING

On final approach and when it is certain that the field can be reached:

1. Landing Gear - DOWN
2. Flaps - AS REQUIRED
3. Airspeed - NORMAL LANDING APPROACH SPEED (90 kts/104 mph)
4. Power - AS REQUIRED to maintain 800 ft/min rate of descent

When it is certain there is no possibility of go-around:

5. Flaps - DOWN
6. Execute normal landing

ONE ENGINE INOPERATIVE GO-AROUND

WARNING

Level flight might not be possible for certain combinations of weight, temperature and altitude. In any event, DO NOT attempt a one engine inoperative go-around after flaps have been fully extended.

1. Power - MAXIMUM ALLOWABLE
2. Landing Gear - UP
3. Flaps - UP (0°)
4. Airspeed - MAINTAIN 100 KTS (115 MPH)

SYSTEMS EMERGENCIES

ONE-ENGINE INOPERATIVE OPERATION ON CROSSFEED

NOTE

The fuel crossfeed system is to be used only during emergency conditions in level flight only.

Left engine inoperative:

1. Right Fuel Boost Pump - LOW
2. Left Fuel Selector Valve - MAIN OR AUXILIARY
3. Right Fuel Selector Valve - CROSSFEED
4. Right Fuel Boost Pump - LOW or OFF as required

Right engine inoperative:

1. Left Fuel Boost Pump - LOW
2. Right Fuel Selector Valve - MAIN OR AUXILIARY
3. Left Fuel Selector Valve - CROSSFEED
4. Left Fuel Boost Pump - LOW or OFF as required

ELECTRICAL SMOKE OR FIRE

Action to be taken must consider existing conditions and equipment installed:

1. Battery and Generator/Alternator Switches - OFF

WARNING

Electrically driven flight instruments will become inoperative.

2. Oxygen - AS REQUIRED
3. All Electrical Switches - OFF

4. Battery and Generator/Alternator Switches - ON
5. Essential Electrical Equipment - ON (Isolate defective equipment:

NOTE

Ensure fire is out and will not be aggravated by draft. Turn off CABIN HEAT switch and push in the CABIN AIR control. Open pilot's storm window, if required.

ILLUMINATION OF OVERVOLTAGE LIGHT OR ALTERNATOR OUT LIGHT(S)

In the event of the illumination of a single ALTERNATOR OUT light:

1. Check the respective loadmeter for load indication
 - a. No Load - Turn off affected alternator
 - b. Regulate load

In the event of the illumination of the overvoltage light or of both ALTERNATOR OUT lights:

1. Check loadmeters for load indication
 - a. No load indicates failure of regulator
 - (1) Switch regulators
 - (2) System should indicate normal
 - b. If condition recurs
 - (1) Switch to original regulator
 - (2) System returns to normal, indicates overload condition causing malfunction
 - (3) Reduce load
 - c. If condition indicates malfunction of both alternator circuits
 - (1) Both ALT Switches - OFF
 - (2) Minimize electrical load since only battery power will be available

LANDING GEAR MANUAL EXTENSION

Reduce airspeed before attempting manual extension of the landing gear.

1. LDG GR MOTOR Circuit Breaker - PULL
2. Landing Gear Handle - DOWN
3. Remove cover from handcrank at rear of front seats. Engage handcrank and turn counterclockwise as far as possible (approximately 50 turns). Stow handcrank.
4. Check mechanical indicator to ascertain that gear is down.
5. If electrical system is operative, check landing gear position lights and warning horn (check LDG GR RELAY circuit breaker engaged.)

CAUTION

The manual extension system is designed only to lower the landing gear; do not attempt to retract the gear manually.

WARNING

Do not operate the landing gear electrically with the handcrank engaged, as damage to the mechanism could occur.

After emergency landing gear extension, do not move any landing gear controls or reset any switches or circuit breakers until airplane is on jacks, as failure may have been in the gear-up circuit and gear might retract with the airplane on the ground.

**LANDING GEAR RETRACTION AFTER
PRACTICE MANUAL EXTENSION**

After practice manual extension of the landing gear, the gear may be retracted electrically, as follows:

1. Handcrank - CHECK, STOWED
2. Landing Gear Motor Circuit Breaker - IN
3. Landing Gear Handle - UP

ICE PROTECTION

SURFACE DEICE SYSTEM

- a. Failure of AUTO Operation
 - (1) Surface Deice Switch - MANUAL (Do not hold more than 8 seconds)

CAUTION

The boots will inflate only as long as the switch is held in the MANUAL position. When the switch is released the boots will deflate.

- b. Failure of boots to deflate
 - (1) Pull circuit breaker on lower left instrument panel

***ELECTROTHERMAL PROPELLER DEICE
SYSTEM***

1. Loss of one alternator; turn off unnecessary electrical equipment. Turn the prop deice system off while operating the cabin heater blower or the landing gear motor. Monitor electrical loads so as not to exceed alternator capacity of 1.0 on the loadmeter.

Section III **BEECHCRAFT Baron B55**
Emergency Procedures TC-371, TC-502 thru TC-1607

An abnormal reading on the Propeller Deice Ammeter indicates need for the following action:

a. **Zero Amps:**

Check prop deice circuit breaker. If the circuit breaker has tripped, a wait of approximately 30 seconds is necessary before resetting. If ammeter reads 0 and the circuit breaker has not tripped or if the ammeter still reads 0 after the circuit breaker has been reset, turn the switch off and consider the prop deice system inoperative.

b. **Zero to 7 Amps, 2 Blade Propeller; Zero to 14 Amps, 3 Blade Propeller:**

If the prop deice system ammeter occasionally or regularly indicates less than 7 amps for 2 blade, (or 14 amps for 3 blade), operation of the prop deice system can continue unless serious propeller imbalance results from irregular ice throw-offs.

c. **12 to 15 Amps, 2 Blade Propeller; 18 to 23 Amps, 3 Blade Propeller:**

If the prop deicing system ammeter occasionally or regularly indicates 12 to 15 amps for 2 blade (or 18 to 23 amps for 3 blade), operation of the prop deice system can continue unless serious propeller imbalance results from irregular ice throw-offs.

d. **More than 15 Amps, 2 Blade Propeller, More than 23 amps, 3 Blade Propeller:**

If the prop deice system ammeter occasionally or regularly indicates more than 15 amps for 2 blade, or more than 23 amps for 3 blade, the system should not be operated unless the need for prop deicing is urgent.

EMERGENCY STATIC AIR SOURCE SYSTEM

THE EMERGENCY STATIC AIR SOURCE SHOULD BE USED FOR CONDITIONS WHERE THE NORMAL STATIC SOURCE HAS BEEN OBSTRUCTED. When the airplane has been exposed to moisture and/or icing conditions (especially on the ground), the possibility of obstructed static ports should be considered. Partial obstructions will result in the rate of climb indication being sluggish during a climb or descent. Verification of suspected obstruction is possible by switching to the emergency system and noting a sudden sustained change in rate of climb. This may be accompanied by abnormal indicated airspeed and altitude changes beyond normal calibration differences.

Whenever any obstruction exists in the Normal Static Air System or the Emergency Static Air System is desired for use:

1. Emergency Static Air Source - Valve - OPEN (lower sidewall adjacent to pilot).
2. For Airspeed Calibration and Altimeter Corrections, refer to the PERFORMANCE section.

CAUTION

The emergency static air valve should remain in the CLOSED position when system is not needed.

EMERGENCY EXITS

Emergency exits, provided by the openable window on each side of the cabin, may be used for egress in addition to the cabin door and the optional cargo door. An emergency exit placard is installed below the left and right middle windows.

To open each emergency exit:

1. Lift the latch.
2. Pull out the emergency release pin and push the window out.

UNLATCHED DOOR IN FLIGHT

If the cabin door is not locked it may come unlatched in flight. This may occur during or just after take-off. The door will trail in a position approximately 3 to 4 inches open. Flight characteristics of the airplane will not be affected except for a reduction in performance. Return to the field in a normal manner. If practicable, during the landing flare-out have a passenger hold the door to prevent it from swinging open.

SIMULATED ONE ENGINE INOPERATIVE

ZERO THRUST (Simulated Feather)

Use the following power setting (only on one engine at a time) to establish zero thrust. Use of this power setting avoids the difficulties of restarting an engine and preserves the availability of engine power.

The following procedure should be accomplished by alternating small reductions of propeller and then throttle, until the desired setting has been reached.

BEEHCRAFT Baron B55 **Section III**
TC-371, TC-502 thru TC-1607 **Emergency Procedures**

1. Propeller Lever - RETARD TO FEATHER DETENT
2. Throttle Lever - SET 12 in. Hg MANIFOLD PRESSURE

NOTE

This setting will approximate Zero Thrust using recommended One-Engine Inoperative Climb speeds.

SPINS

If a spin is entered inadvertently:

Immediately move the control column full forward, apply full rudder opposite to the direction of the spin and reduce power on both engines to idle. These three actions should be done as near simultaneously as possible; then continue to hold this control position until rotation stops and then neutralize all controls and execute a smooth pullout. Ailerons should be neutral during recovery.

NOTE

Federal Aviation Administration Regulations did not require spin demonstration of airplanes of this weight; therefore, no spin tests have been conducted. The recovery technique is based on the best available information.

SECTION IV

NORMAL PROCEDURES

TABLE OF CONTENTS

<i>SUBJECT</i>	<i>PAGE</i>
Airspeeds for Safe Operation (5100 Lbs.)	4-3
Preflight Inspection	4-4
Before Starting	4-6
Starting	4-7
After Starting and Taxi	4-8A
Before Takeoff	4-9
Take-Off	4-10
Maximum Performance Climb	4-10
Cruise Climb	4-10
Cruise	4-11
Leaning Using EGT	4-11
Descent	4-12
Before Landing	4-12
Balked Landing	4-13
After Landing	4-13
Shutdown	4-13
Oxygen System	4-14
Cold Weather Operation	4-17
Preflight Inspection	4-17
Engines	4-18
External Power	4-19
Starting Engines Using	
Auxiliary Power Unit	4-19
Taxiing	4-20

TABLE OF CONTENTS (Continued)

<i>SUBJECT</i>	<i>PAGE</i>
Ice Protection Systems	4-20
Emergency Static Air Source	4-21
Surface Deice System	4-21
Electrothermal Propeller Deice	4-22
Propeller and Windshield Anti-Ice System (Fluid Flow)	4-23
Pitot Heat and Heated Stall Warning	4-24
Windshield Defogging	4-24
Engine Break-In Information	4-24
Practice Demonstration of V_{MCA}	4-25

All airspeeds quoted in this section are indicated airspeeds (IAS) and assume zero instrument error.

AIRSPEEDS FOR SAFE OPERATION (5100 LBS)

Maximum Demonstrated Crosswind

Component 22 kts/25 mph

Takeoff:

Lift-off 84 kts/97 mph

50-ft Speed 91 kts/105 mph

Two-Engine Best Angle-of-Climb

(V_X) 84 kts/97 mph

Two-Engine Best Rate-of-Climb

(V_Y) 107 kts/123 mph

Cruise Climb 122 kts/140 mph

Turbulent Air Penetration 157 kts/181 mph

Landing Approach:

Flaps DN 90 kts/104 mph

Flaps 0° 97 kts/112 mph

Balked Landing Climb 90 kts/104 mph

Intentional One-Engine-Inoperative

Speed (V_{SSE}) 84 kts/97 mph

Air Minimum Control Speed (V_{MCA}) 78 kts/90 mph

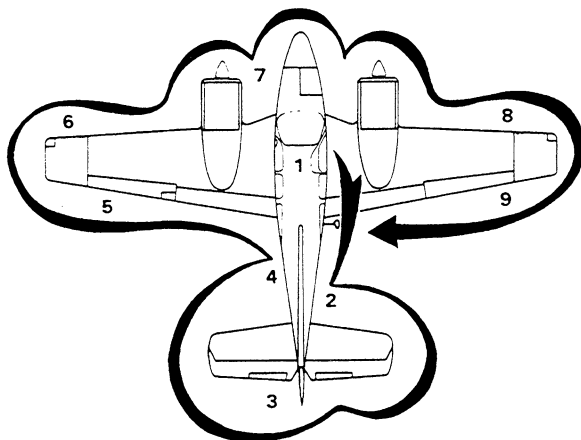

PREFLIGHT INSPECTION

Emergency Locator Transmitter - ARMED. Location may vary with individual airplanes.

1. COCKPIT:
 - a. Control Lock - REMOVE AND STOW
 - b. Parking Brake - SET
 - c. All Switches - OFF
 - d. Trim Tabs - SET TO ZERO

2. RIGHT FUSELAGE:
 - a. Load Distribution - CHECK AND SECURED
 - b. Baggage Door - SECURE
 - c. Static Port - UNOBSTRUCTED

3. EMPENNAGE:
 - a. Control Surfaces, Tabs and Deice Boots - CHECK CONDITION, SECURITY, AND ATTACHMENT
 - b. Tail Cone, Tail Light, and Beacon - CHECK
 - c. Tie Down - REMOVE
 - d. Cabin Air Inlet - CHECK

4. LEFT FUSELAGE:
 - a. Cabin Air Outlet - CHECK
 - b. Static Port - UNOBSTRUCTED
 - c. All Antennas and Lower Beacon - CHECK

5. LEFT WING TRAILING EDGE:
 - a. Fuel Sump Aft of Wheel Well - DRAIN
 - b. Fuel Vents - CHECK
 - c. Flaps - CHECK GENERAL CONDITION
 - d. Aileron - CHECK CONDITION AND FREEDOM OF MOVEMENT, TAB NEUTRAL WHEN AILERON NEUTRAL

6. LEFT WING LEADING EDGE
 - a. Lights and Deice Boot - CHECK FOR CONDITION
 - b. Stall Warning Vane - CHECK FREEDOM OF MOVEMENT

- c. Fuel - CHECK QUANTITY AND SECURE CAPS
 - d. Pitot - REMOVE COVER, EXAMINE FOR OBSTRUCTIONS
 - e. Tie Down, Chocks - REMOVE
 - f. Engine Oil - CHECK QUANTITY, CAP AND DOOR SECURE
 - g. Engine Cowling and Doors - CHECK CONDITION AND SECURITY
 - h. Engine Air Intake - EXAMINE FOR OBSTRUCTIONS
 - i. Propeller - EXAMINE FOR NICKS, SECURITY AND OIL LEAKS
 - j. Cowl Flap - CHECK
 - k. Wheel Well Doors, Tire, Brake Line and Shock Strut - CHECK
 - l. Landing Gear Uplock Roller - CHECK
 - m. Fuel Drains - DRAIN (3)
- 7. NOSE SECTION**
- a. Wheel Well Doors, Tire and Shock Strut - CHECK
 - b. Heater Fuel Strainer - DRAIN
 - c. Taxi Light - CHECK
 - d. Heater Air Inlets - CLEAR
 - e. Oxygen - CHECK
 - f. Baggage Door - SECURE
- 8. RIGHT WING LEADING EDGE**
- a. Wheel Well Doors, Tire, Brake Line, and Shock Strut - CHECK
 - b. Landing Gear Uplock Roller - CHECK
 - c. Cowl Flap - CHECK
 - d. Fuel Drains - DRAIN (3)
 - e. Engine Oil - CHECK QUANTITY, CAP AND DOOR SECURE
 - f. Engine Cowling and Doors - CHECK CONDITION AND SECURITY
 - g. Propeller - EXAMINE FOR NICKS, SECURITY AND OIL LEAKS

- h. Engine Air Intake - EXAMINE FOR OBSTRUCTIONS
 - i. Fuel - CHECK QUANTITY AND SECURE CAPS
 - j. Tie Down and Chocks - REMOVE
 - k. Lights and Deice Boot - CHECK FOR CONDITION
9. RIGHT WING TRAILING EDGE
- a. Aileron - CHECK CONDITION AND FREEDOM OF MOVEMENT
 - b. Fuel Vents - CHECK
 - c. Fuel Sump Aft of Wheel Well - DRAIN
 - d. Flaps - CHECK GENERAL CONDITION

NOTE

Check operation of lights if night flight is anticipated.

CAUTION

DO NOT TAXI WITH A FLAT SHOCK STRUT.

BEFORE STARTING

- 1. Seats - POSITION AND LOCK SEAT BACKS UPRIGHT
- 2. Seat Belts - FASTEN
Shoulder Harnesses if installed - FASTEN
- 3. Parking Brake - SET
- 4. All Avionics - OFF
- 5. Oxygen - CHECK QUANTITY AND OPERATION
- 6. Landing Gear Handle - DOWN
- 7. Cowl Flap Switches - CHECK, OPEN. Check position light - ON
- 8. Fuel Selector Valves - CHECK OPERATION THEN SET TO MAIN
- 9. All Circuit Breakers, Switches and Equipment Controls - CHECK
- 10. Battery Switch - ON

CAUTION

The generator/alternator control switches must be turned OFF prior to connecting an auxiliary power unit for starting, battery charging or electrical equipment check-out. This procedure protects the voltage regulators and system electrical equipment from voltage transients (power fluctuations).

11. Fuel Quantity Indicators - CHECK QUANTITY MAIN AND AUXILIARY. Fuel quantity selector switch to MAIN. (See LIMITATIONS for take-off fuel)
12. Landing Gear Position Lights - CHECK

STARTING

1. Throttle Position - APPROXIMATELY 1/2 IN. OPEN
2. Propeller Control - LOW PITCH (high rpm)
3. Mixture Control - FULL RICH

NOTE

If the engine is hot, and the ambient temperature is 90°F or above, place mixture control in IDLE CUT-OFF, switch fuel boost pump to HIGH for 30 to 60 seconds, then OFF. Return mixture control to FULL RICH.

4. Fuel Boost Pump - HIGH (until pressure stabilizes then - OFF)

CAUTION

Do not engage starter for more than 30 seconds in any 4-minute period.

5. Magneto/Start Switch - START (Observe Starter Limits)

NOTE

In the event of a balked start (or overprime condition) place mixture control in IDLE CUT-OFF and open the throttle; operate the starter to remove excess fuel. As engine starts, reduce the throttle to idle rpm and place the mixture control in FULL RICH.

6. Warm-up - 800 to 1200 RPM
7. Oil Pressure - 25 PSI WITHIN 30 SECONDS
8. External Power (if used) - DISCONNECT

WARNING

When using external power, start the right engine first. Disconnect external power before starting left engine.

9. Generator/Alternator Switch - ON
10. All Engine Indicators - CHECK

CAUTION

If the total of both loadmeters exceeds .2 after two minutes at 1000-1200 rpm, with no additional electrical equipment on, and the indication shows no signs of decreasing, an electrical malfunction is indicated. The battery master and both generator/alternator switches should be placed in the OFF position. Do not take off.

CAUTION

Low voltage, high ammeter or loadmeter readings, dimming of lights, or excessive noise in radio receivers could be indications that problems are developing in the starter system. A noted change in such normal conditions could indicate prolonged starter motor running and the engine should be shut down. No further flight operations should be attempted until the cause is determined and repaired.

11. Using the same procedure, start other engine.

AFTER STARTING AND TAXI

CAUTION

Do not operate engine above 1200 RPM until oil temperature reaches 75°F.

1. Brakes - RELEASE AND CHECK
2. Avionics - ON, AS REQUIRED
3. Exterior Lights - AS REQUIRED

INTENTIONALLY LEFT BLANK

BEFORE TAKEOFF

1. Seat Belts and Shoulder Harnesses - CHECK
2. Parking Brake - SET
3. Fuel Boost Pumps - OFF (If ambient temperature is 90°F or above, use LOW pressure boost)
4. All Instruments - CHECKED
5. Fuel Selector Valves - CHECK (MAIN TANKS)
6. Mixture - FULL RICH (or as required by field elevation)
7. Propellers - EXERCISE AT 2200 RPM

CAUTION

When exercising propellers in their governing range, do not move the control lever aft past the detent. To do so will allow the propeller to change rapidly to the full feathered position, imposing high stresses on the blade shank and engine.

8. Loadmeters - CHECK for proper indication
9. Throttles - 1700 RPM
10. Magnetos - CHECK (Variance between individual magnetos should not exceed 50 rpm, max. drop 150 rpm)
11. Throttles - 1500 RPM
12. Propellers - FEATHERING CHECK (Do not allow an rpm drop of more than 500 rpm)
13. Throttles - IDLE
14. Friction - ADJUST
15. Trim - AS REQUIRED FOR TAKE-OFF
16. Flaps - CHECK AND SET FOR TAKE-OFF
17. Flight Controls - CHECK PROPER DIRECTION, FULL TRAVEL AND FREEDOM OF MOVEMENT
18. Doors and Windows - LOCKED
19. Parking Brake - OFF

TAKE-OFF

Take-Off Power Full throttle, 2625 rpm

Minimum Take-Off Oil Temperature 75°F

1. Power - SET TAKE-OFF POWER (MIXTURE - SET FUEL PRESSURE TO ALTITUDE) BEFORE BRAKE RELEASE
2. Airspeed - ACCELERATE TO AND MAINTAIN RECOMMENDED SPEED
3. Landing Gear - RETRACT (when positive rate of climb is established)
4. Airspeed - ESTABLISH DESIRED CLIMB SPEED (when clear of obstacles)

MAXIMUM PERFORMANCE CLIMB

1. Power - SET MAXIMUM CONTINUOUS POWER
2. Mixtures - LEAN TO APPROPRIATE FUEL PRESSURE
3. Cowl Flaps - OPEN
4. Airspeed - ESTABLISH 107 KTS/123 MPH

CRUISE CLIMB

1. Power - SET (25.0 in. Hg or Full Throttle - 2500 RPM)
2. Mixture Controls - LEAN TO APPROPRIATE FUEL PRESSURE
3. Airspeed - 122 KTS/140 MPH
4. Cowl Flaps - AS REQUIRED

NOTE

In high ambient temperatures, low pressure boost may be required to prevent excessive fuel flow fluctuations.

CRUISE

Maximum Cruise Power 24.5 in. Hg at 2450 rpm
Recommended Cruise Power . . 24.0 in. Hg at 2300 rpm
Recommended Cruise Power . . 22.0 in. Hg at 2200 rpm
Economy Cruise Power 20.0 in. Hg at 2100 rpm

1. Power - SET AS DESIRED (Use Tables in PERFORMANCE section)
2. Fuel Flow - LEAN AS REQUIRED
3. Cowl Flaps - AS REQUIRED

LEANING USING THE EXHAUST GAS TEMPERATURE INDICATOR (EGT)

A thermocouple type exhaust gas temperature (EGT) probe is mounted in the system. This probe is connected to an indicator on the instrument panel. The indicator is calibrated in degrees Fahrenheit. Use EGT system to lean the fuel/air mixture when cruising at maximum cruise power or less.

1. Lean the mixture and note the point on the indicator that the temperature peaks and starts to fall.
 - a. CRUISE (LEAN) MIXTURE - Increase the mixture until the EGT shows a drop of 25°F below peak on the rich side of peak.
 - b. BEST POWER MIXTURE - Increase the mixture until the EGT shows a drop of 100°F below peak on the rich side of peak.

CAUTION

Do not continue to lean mixture beyond that necessary to establish peak temperature.

Section IV
Normal Procedures

BEEHCRAFT Baron B55
TC-371, TC-502 thru TC-1607

2. Continuous operation is recommended at 25°F or more below peak EGT only on the rich side of peak.
3. Changes in altitude and power settings require the peak EGT to be rechecked and the mixture reset.

DESCENT

1. Altimeter - SET
2. Cowl Flaps - CLOSED
3. Windshield Defroster - AS REQUIRED
4. Power - AS REQUIRED (avoid prolonged idle settings and low cylinder head temperatures)
5. Fuel Selector Valves - MAIN

Recommended descent speeds:

Smooth air 172 kts/198 mph
Rough air (Max.) 157 kts/181 mph

BEFORE LANDING

1. Seat Belts - FASTENED, SEAT BACKS UPRIGHT
Shoulder Harnesses if installed - FASTENED
2. Fuel Selector Valves - CHECK (MAIN TANKS)
3. Fuel Boost Pumps - OFF, OR LOW AS PER AMBIENT TEMPERATURE
4. Cowl Flaps - AS REQUIRED
5. Mixture Controls - FULL RICH (or as required by field elevation)
6. Landing Gear - DOWN
7. Flaps - DOWN
8. Airspeed - ESTABLISH NORMAL LANDING APPROACH SPEED.
9. Propellers - LOW PITCH (high rpm)

BALKED LANDING

1. Propellers - LOW PITCH (high rpm)
2. Power - MAXIMUM ALLOWABLE
3. Airspeed - BALKED LANDING CLIMB SPEED (90 KTS/104 MPH)
4. Flaps - UP
5. Landing Gear - UP
6. Cowl Flaps - AS REQUIRED

AFTER LANDING

1. Landing and Taxi Lights - AS REQUIRED
2. Flaps - UP
3. Trim Tabs - SET TO ZERO
4. Cowl Flaps - OPEN
5. Fuel Boost Pumps - AS REQUIRED

SHUT DOWN

1. Parking Brake - SET
2. Propellers - HIGH RPM
3. Throttles - 1000 RPM
4. Fuel Boost Pumps - OFF
5. Electrical and Avionics Equipment - OFF
6. Mixture Controls - IDLE CUT-OFF
7. Magneto/Start Switches - OFF, AFTER ENGINES STOP
8. Battery and Generator/Alternator Switches - OFF
9. Controls - LOCKED
10. If airplane is to be parked for an extended period of time, install wheel chocks and release the parking brake as greatly varying ambient temperatures may build excessive pressures on the hydraulic system.

OXYGEN SYSTEM

WARNING

NO SMOKING permitted when using oxygen.

PREFLIGHT

1. Check Oxygen Pressure Gage for pressure reading.
2. Determine percent of full system.
3. Multiply oxygen duration in minutes by percent of full system.

EXAMPLE:

(Using chart for serials TC-1030 thru TC-1607)

People	5
Gage Pressure	1500 psi
Percent Capacity (from chart)	80%
Cylinder Capacity (full)	49 cu ft
Altitude (planned flight)	15,000 feet
Duration (full cylinder)	149 minutes
Duration (80% full)	119 minutes

OXYGEN DURATION

The recommended masks are provided with the system. They are designed to be adjustable to fit the average person, with minimum leakage of oxygen.

CAUTION

Since 90% of the system efficiency is determined by the fit of the oxygen mask, make certain the masks fit properly and are in good condition.

**OXYGEN AVAILABLE WITH
 PARTIALLY FULL BOTTLE**

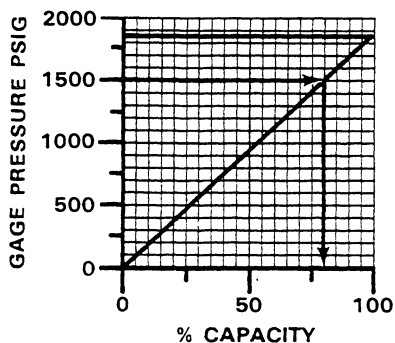

OXYGEN DURATION CHART

(TC-371, TC-502 thru TC-954)

Duration in minutes at the following altitudes:

	Persons Using	12,500	15,000	20,000
38 cu ft	1	411	396	360
	2	231	222	204
	3	162	156	144
	4	123	120	114
	5	99	96	90
	6	82	80	74
48 cu ft	1	516	498	456
	2	291	282	258
	3	204	198	180
	4	156	150	138
	5	126	120	114
	6	105	99	97

OXYGEN DURATION CHART (Continued)

(TC-955 thru TC-1029)

Duration in minutes at the following altitudes:

	Persons Using	12,500	15,000	20,000
38 cu ft	1	301	307	319
	2	150	153	159
	3	100	102	106
	4	75	76	79
	5	60	61	63
	6	50	51	53
48 cu ft	1	379	386	402
	2	187	193	201
	3	126	128	134
	4	95	96	100
	5	75	77	80
	6	63	64	67

(TC-1030 thru TC-1607)

Duration in minutes at the following altitudes:

	Persons Using	12,500	15,000	20,000
38 cu ft	1	774	569	387
	2	387	284	193
	3	258	189	129
	4	189	142	96
	5	154	113	77
	6	129	94	64
49 cu ft	1	1014	746	507
	2	507	373	253
	3	338	248	169
	4	253	186	126
	5	202	149	101
	6	169	124	84
66 cu ft	1	1344	988	672
	2	672	494	336
	3	448	329	224
	4	336	247	168
	5	268	197	134
	6	224	164	112

IN FLIGHT

The use of oxygen is recommended to be in accordance with current FAR operating rules.

1. Oxygen Control Valve - OPEN SLOWLY
2. Mask - INSERT FITTING, DON MASK (adjust mask for proper fit)
3. Oxygen Flow - CHECK (depending upon mask configuration, note that red plunger lifts from its seat when the hose is inserted into the oxygen coupling; or check for flow of oxygen into mask by closing off the opening from breather bag to mask noting that the bag expands.)

AFTER USING

1. Discontinue use by unplugging mask from outlet.

NOTE

Closing the control valve while in flight is not necessary due to automatic sealing of the outlet when the mask is unplugged.

2. Oxygen Control Valve - CLOSE (may be accomplished during shut-down).

COLD WEATHER OPERATION

PREFLIGHT INSPECTION

In addition to the normal preflight exterior inspection, remove ice, snow and frost from the wings, tail, control surfaces and hinges, propellers, windshield, fuel cell filler caps and fuel vents, and crankcase breathers. If you have no way of removing these formations of ice, snow, and frost leave the airplane on the ground, as these deposits will not blow off. The wing contour may be changed by these formations sufficiently that its lift qualities are considerably disturbed and sometimes completely

destroyed. Complete your normal preflight procedures. Check the flight controls for complete freedom of movement.

Conditions for accumulating moisture in the fuel tanks are most favorable at low temperatures due to the condensation increase and the moisture that enters as the system is serviced. Therefore, close attention to draining the fuel system will assume particular importance during cold weather.

ENGINES

Use engine oil in accordance with Consumable Materials in the SERVICING section. Always pull the propeller through by hand several times to clear the engine and "limber up" the cold, heavy oil before using the starter. This will also lessen the load on the battery if an auxiliary power unit is not used.

Under very cold conditions, it may be necessary to preheat the engine prior to a start. Particular attention should be applied to the oil cooler, and engine sump to insure proper preheat. A start with congealed oil in the system may produce an indication of normal pressure immediately after the start, but then the oil pressure may decrease when residual oil in the engine is pumped back with the congealed oil in the sump. If an engine heater capable of heating both the engine sump, and cooler is not available, the oil should be drained while the engines are hot and stored in a warm area until the next flight.

If there is no oil pressure within the first 30 seconds of running, or if oil pressure drops after a few minutes of ground operation, shut down and check for broken oil lines, oil cooler leaks or the possibility of congealed oil.

NOTE

It is advisable to use external power for starting in cold weather.

During warm-up, watch engine temperatures closely, since it is quite possible to exceed the cylinder head temperature limit in trying to bring up the oil temperature. Exercise the propellers several times to remove cold oil from the pitch change mechanisms. The propellers should also be cycled occasionally in flight.

During letdown and landing, give special attention to engine temperatures, since the engines will have a tendency toward overcooling.

EXTERNAL POWER

It is very important that the following precautions be observed while using external power.

1. The airplane has a negative ground system. Be sure to connect the positive lead of the auxiliary power unit to the center post of the airplane's external power receptacle and the negative lead of the auxiliary power unit to the other large post. If the aircraft is equipped with a reverse polarity relay (TC-1011 and after), positive power must also be connected to the small guide pin.
2. To prevent arcing, make certain no power is being supplied when the connection is made.
3. Make certain that the battery switch is ON, all avionics and electrical switches OFF, and a battery is in the system before connecting an external power unit. This protects the voltage regulators and associated electrical equipment from voltage transients (power fluctuations).

STARTING ENGINES USING AUXILIARY POWER UNIT

1. Battery switch - ON

Section IV
Normal Procedures

BEEHCRAFT Baron B55
TC-371, TC-502 thru TC-1607

2. Generators/Alternators, Electrical, and Avionics Equipment - OFF
3. Auxiliary Power Unit - CONNECT
4. Auxiliary Power Unit - SET OUTPUT (27.0 to 28.5 volts)
5. Auxiliary Power Unit - ON
6. Right Engine - START (use normal start procedures)
7. Auxiliary Power Unit - OFF (after engine has been started)
8. Auxiliary Power Unit - DISCONNECT (before starting left engine)
9. Generator/Alternator Switches - ON

TAXIING

Avoid taxiing through water, slush or muddy surfaces if possible. In cold weather, water, slush or mud, when splashed onto landing gear mechanisms or control surface hinges may freeze, preventing free movement and resulting in structural damage.

ICE PROTECTION SYSTEMS

The following equipment, when installed and operable, will provide a degree of protection when icing conditions are inadvertently encountered. Since this equipment has not been demonstrated to meet current requirements for flight into known icing conditions, the pilot must exit such conditions as soon as possible if ice accumulates on the airplane.

1. Equipment required for IFR flight
2. Beech approved emergency static air source
3. Beech approved surface deice system

4. Beech approved propeller deice or anti-ice system
5. Beech approved pitot heat
6. Beech approved heated stall warning
7. Beech approved heated fuel vents
8. Beech approved windshield defogging and openable storm window
9. Beech approved alternate induction air
10. Beech approved external antenna masts (capable of withstanding ice loads)

WARNING

Stalling airspeeds should be expected to increase due to the distortion of the wing airfoil when ice has accumulated on the airplane. For the same reason, stall warning devices are not accurate and should not be relied upon. With ice on the airplane, maintain a comfortable margin of airspeed above the normal stall airspeed.

1. EMERGENCY STATIC AIR SOURCE

If the Emergency Static Air Source is desired for use:

- a. Emergency Static Air Source - ON EMERGENCY (lower sidewall adjacent to pilot)
- b. For Airspeed Calibration and Altimeter Corrections, refer to PERFORMANCE section

CAUTION

The emergency static air valve should be in the OFF NORMAL position when the system is not needed.

2. SURFACE DEICE SYSTEM

- a. **BEFORE TAKE-OFF**
 - (1) Throttles - 2000 RPM
 - (2) Surface Deice Switch - AUTO (UP)

- (3) Deice Pressure - 9 to 20 PSI (while boots are inflating)
- (4) Wing Boots - CHECK VISUALLY FOR INFLATION AND HOLD DOWN

b. *IN FLIGHT*

When ice accumulates 1/2 to 1 inch

- (1) Surface Deice Switch - AUTO (UP)
- (2) Deice Pressure - 9 to 20 PSI (while boots are inflating)
- (3) Repeat - AS REQUIRED

CAUTION

Rapid cycles in succession or cycling before at least 1/2 inch of ice has accumulated may cause the ice to grow outside the contour of the inflated boots and prevent ice removal.

Stall speeds are increased 4 kts/5 mph in all configurations with surface deice system operating.

NOTE

Either engine will supply sufficient vacuum and pressure for deice operation.

- c. For Emergency Operation refer to the EMERGENCY PROCEDURES section.

3. ELECTROTHERMAL PROPELLER DEICE

CAUTION

Do not operate the propeller deice when propellers are static.

a. *BEFORE TAKEOFF*

- (1) Propeller Deice Switch - ON
- (2) Propeller Deice Ammeter - CHECK, 7 to 12 amps (2 Blade), 14 to 18 amps (3 Blade)

b. IN FLIGHT

- (1) Propeller Deice Switch - ON. The system may be operated continuously in flight and will function automatically until the switch is turned OFF.
- (2) Relieve propeller imbalance due to ice by increasing rpm briefly and returning to the desired setting. Repeat as necessary.

CAUTION

If the propeller deice ammeter indicates abnormal reading, refer to the Emergency Procedures section.

**4. PROPELLER AND WINDSHIELD ANTI-ICE SYSTEM
(FLUID FLOW)**

CAUTION

This anti-ice system is designed to PREVENT the formation of ice. Always turn the system ON before entering icing conditions.

a. PREFLIGHT

- (1) Check the quantity in reservoir
- (2) Check slinger ring and lines for obstructions
- (3) Check propeller boots for damage

b. IN FLIGHT

- (1) Prop Anti-ice Switch - ON
- (2) Windshield Anti-ice Switch - CYCLE AS REQUIRED
- (3) Anti-ice Quantity Indicator - MONITOR

NOTE

See SYSTEM description for endurance.

5. PITOT HEAT AND HEATED STALL WARNING

- a. Pitot Heat Switch(es) - ON (Note deflection on Loadmeter) Heated Stall Warning is activated by the left pitot heat switch.

NOTE

Switches may be left on throughout flight. Prolonged operation on the ground could damage the Pitot Heat System.

6. WINDSHIELD DEFOGGING

- a. Defrost Control - PUSH ON
- b. Pilot's Storm Window - OPEN, AS REQUIRED

ENGINE BREAK-IN INFORMATION

Refer to Systems section.

PRACTICE DEMONSTRATION OF V_{MCA}

V_{MCA} demonstration may be required for multi-engine pilot certification. The following procedure shall be used at a safe altitude of at least 5000 feet above the ground in clear air only.

WARNING

INFLIGHT ENGINE CUTS BELOW V_{SSE}
SPEED OF 84 KTS/97 MPH ARE PROHIBITED.

1. Landing Gear - Up
2. Flaps - Up
3. Airspeed - Above 84 kts/97 mph (V_{SSE})
4. Propeller Levers - High RPM
5. Throttle (Simulated inoperative engine) - Idle
6. Throttle (Other engine) - Maximum Manifold Pressure
7. Airspeed - Reduce approximately 1 knot per second until either V_{MCA} or stall warning is obtained.

CAUTION

Use rudder to maintain directional control (heading) and ailerons to maintain 5° bank towards the operative engine (lateral attitude). At the first sign of either V_{MCA} or stall warning (which may be evidenced by: inability to maintain heading or lateral attitude, aerodynamic stall buffet, or stall warning horn sound) immediately initiate recovery: reduce power to idle on the operative engine and immediately lower the nose to regain V_{SSE} .

INTENTIONALLY LEFT BLANK

SECTION V

PERFORMANCE

TABLE OF CONTENTS

<i>SUBJECT</i>	<i>PAGE</i>
Introduction to Performance and Flight Planning	5-3
Conditions	5-3 - 5-14
Comments Pertinent to the Use of Performance Graphs	5-14
Performance Graphs	5-15 - 5-46
Airspeed Calibration - Normal System	5-15
Altimeter Correction - Normal System	5-16
Airspeed Calibration - Alternate System	5-17
Altimeter Correction - Alternate System	5-18
Fahrenheit to Celsius	5-19
ISA Conversion	5-20
Manifold Pressure vs RPM	5-21
Take-Off Weight	5-22
Stall Speeds - Power Idle	5-23
Wind Components	5-24
Take-Off Distance	5-25
Accelerate - Stop	5-26
Accelerate - Go	5-27
Climb - Two Engine	5-28
Take-Off Climb Gradient, One Engine Inoperative	5-29
Time, Fuel, Distance to Climb	5-30
Climb - One Engine Inoperative	5-31
Service Ceiling - One Engine Inoperative	5-32
October 1978	5-1

TABLE OF CONTENTS (Continued)

<i>SUBJECT</i>	<i>PAGE</i>
Cruise Speeds	5-33
Fuel Flow vs Brake Horsepower	5-34
Fuel Flow vs Fuel Pressure	5-35
Cruise Power Settings	5-36 - 5-39
Maximum Cruise Power	5-36
Recommended Cruise Power	5-37
Recommended Cruise Power	5-38
Economy Cruise Power	5-39
Range Profile - 100 Gallons	5-40
Endurance Profile - 100 Gallons	5-41
Range Profile - 136 Gallons	5-42
Endurance Profile - 136 Gallons	5-43
Holding Time	5-44
Time, Fuel and Distance to Descend	5-45
Climb - Balked Landing	5-46
Landing Distance	5-47

**INTRODUCTION TO PERFORMANCE
AND FLIGHT PLANNING**

All airspeeds quoted in this section are indicated airspeeds (IAS) except as noted and assume zero instrument error.

The graphs and tables in this section present performance information for takeoff, climb, landing and flight planning at various parameters of weight, power, altitude, and temperature. FAA approved performance information is included in this section. Examples are presented on all performance graphs. In addition, the calculations for flight time, block speed, and fuel required are presented using the conditions listed.

For airplanes with maximum takeoff weights less than 5100 lbs read charts at actual weight.

CONDITIONS

At Denver:

Outside Air Temperature 15°C (59°F)
Field Elevation 5330 ft
Altimeter Setting 29.60 in. Hg
Wind 270° at 10 kts
Runway 26L length 10,010 ft

Route of Trip

*DEN-V81-AMA

For VFR Cruise at 11,500 feet

Section V
Performance

BEECHCRAFT Baron B55
TC-371, TC-502 thru TC-1607

ROUTE SEGMENT	MAGNETIC COURSE	DIST NM	WIND 11500 FEET DIR/KTS	OAT 11500 FEET °C	ALT SETTING IN.HG
DEN-COS	161°	55	010/30	-5	29.60
COS-PUB	153°	40	010/30	-5	29.60
PUB-TBE	134°	74	100/20	0	29.56
TBE-DHT	132°	87	200/20	9	29.56
DHT-AMA	125°	65	200/20	10	29.56

*REFERENCE: Enroute Low Altitude Chart L-6

At Amarillo:

Outside Air Temperature 25°C (77°F)
 Field Elevation 3605 ft
 Altimeter Setting 29.56 in. Hg
 Wind 180° at 10 kts
 Runway 21 Length 10,000 ft

To determine pressure altitude at origin and destination airports, add 100 feet to field elevation for each .1 in. Hg below 29.92, and subtract 100 feet from field elevation for each .1 in. Hg above 29.92.

Pressure Altitude at DEN:

$$29.92 - 29.60 = .32 \text{ in. Hg}$$

The pressure altitude at DEN is 320 feet above the field elevation.

$$5330 + 320 = 5650 \text{ ft}$$

Pressure Altitude at AMA:

$$29.92 - 29.56 = .36 \text{ in. Hg}$$

The pressure altitude at AMA is 360 feet above the field elevation.

$$3605 + 360 = 3965 \text{ ft}$$

NOTE

For flight planning, the difference between cruise altitude and cruise pressure altitude has been ignored.

Maximum Allowable Take-off Weight = 5100 lbs

Ramp Weight = 5100 + 21 = 5121 lbs

NOTE

Fuel for start, taxi and take-off is normally 21 pounds.

Enter the Take-Off Weight graph at 5650 feet pressure altitude and 15°C.

The take-off weight to achieve a positive rate-of-climb at lift-off for one engine inoperative is:

Take-off Weight = 4550 pounds

Section V
Performance

BEEHCRAFT Baron B55
TC-371, TC-502 thru TC-1607

Enter the Take-Off Distance graph at 15°C, 5650 feet pressure altitude, 5100 pounds, and 9.5 knots headwind component.

Ground Roll	2000 ft
Total Distance over 50 ft Obstacle	3200 ft
Lift-off Speed	84 kts/97 mph
50 Foot Speed	91 kts/105 mph

Enter the Accelerate-Stop graph at 15°C, 5650 feet pressure altitude, 5100 pounds, and 9.5 knots headwind component:

Accelerate-Stop Distance	4100 ft
Engine Failure Speed	84 kts/97 mph

NOTE

Since 4100 feet is less than the available field length (10,010 ft), the accelerate-stop procedure can be performed at any weight.

Take-off at 5100 lbs can be accomplished. However, if an engine failure occurs before becoming airborne, the accelerate-stop procedure must be performed.

The following example assumes the airplane is loaded so that the take-off weight is 4550 pounds.

Although not required by regulations, information has been presented to determine the take-off weight, field requirements and take-off flight path assuming an engine failure occurs during the take-off procedure. The following illustrates the use of these charts.

Enter the Accelerate-Go graph at 15°C, 5650 feet pressure altitude, 4550 pounds, and 9.5 knots headwind component:

Ground Roll	1800 ft
Total Distance Over 50 ft Obstacle	7100 ft
Lift-off Speed	84 kts/97 mph
50 Foot Speed	91 kts/105 mph

Enter the graph for Take-off Climb Gradient - One Engine Inoperative at 15°C, 5650 feet pressure altitude, and 4550 pounds.

Climb Gradient	2.2%
Climb Speed	91 kts/105 mph

A 2.2% climb gradient is 22 feet of vertical height per 1000 feet of horizontal distance.

NOTE

The Climb Gradient - One Engine Inoperative graph assumes zero wind conditions. Climbing into a headwind will result in higher angles of climb, and hence, better obstacle clearance capabilities.

Section V
Performance

BEEHCRAFT Baron B55
TC-371, TC-502 thru TC-1607

Calculation of horizontal distance to clear an obstacle 90 feet above the runway surface:

Horizontal distance used to climb from 50 feet to 90 feet = $(90-50) (1000 \div 22) = 1818$ feet

Total Distance = $7100 + 1818 = 8918$ feet

The above results are illustrated below:

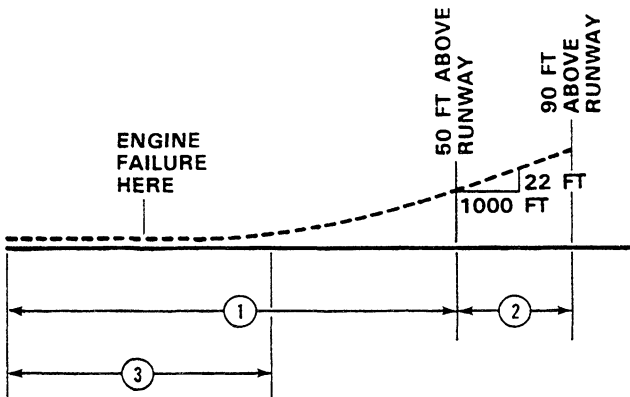

- ① Accelerate-go take-off distance = 7100 feet
- ② Distance to climb from 50 ft. to 90 ft above runway = 1818 feet
- ③ Accelerate-stop distance for 5100 lbs. take-off weight = 4100 feet

The following calculations provide information for the flight planning procedure. All examples are presented on the performance graphs. A take-off weight of 5100 pounds has been assumed.

Enter the Time, Fuel, and Distance to Climb graph at 15°C to 5650 feet and to 5100 pounds. Also enter at -5°C to 11,500 feet and to 5100 pounds. Read:

Time to Climb = (10-4) = 6 min
Fuel Used to Climb = (5.7-2.5) = 3.2 gal
Distance Traveled = (22-9) = 13 NM

The temperatures for cruise are presented for a standard day (ISA); 20°C (36°F) above a standard day (ISA + 20°C); and 20°C (36°F) below a standard day (ISA - 20°C). These should be used for flight planning. The IOAT values are true temperature values which have been adjusted for the compressibility effects. IOAT should be used for setting cruise power while enroute.

Enter the graph for ISA conversion at 11,500 feet and the temperature for the route segment:

DEN-PUB	OAT	=	-5°C
	ISA Condition	=	ISA + 3°C
PUB-TBE	OAT	=	0°C
	ISA Condition	=	ISA + 8°C
TBE-DHT	OAT	=	9°C
	ISA Condition	=	ISA + 17°C
DHT-AMA	OAT	=	10°C
	ISA Condition	=	ISA + 18°C

Section V
Performance

BEEHCRAFT Baron B55
TC-371, TC-502 thru TC-1607

Enter the table for recommended cruise power - 24 in. Hg, 2300 rpm at 10,000 ft, 12,000 ft, ISA and ISA + 20°C.

	TEMPERATURE					
	ISA			ISA + 20°C		
ALTI- TUDE FEET	MAN. PRESS. IN. HG	FUEL FLOW GPH/ ENG	TAS KTS/ MPH	MAN. PRESS. IN. HG	FUEL FLOW GPH/ ENG	TAS KTS/ MPH
10000	20.2	10.9	176/ 203	20.2	10.6	177/ 204
12000	18.7	10.2	173/ 199	18.7	10.0	174/ 200

Interpolate for 11,500 feet and the temperature for the appropriate route segment. Results of the interpolations are:

ROUTE SEGMENT	MAN. PRESS. IN. HG	FUEL FLOW GPH/ENG	TAS KTS/ MPH
DEN-PUB	19.1	10.4	175/ 201
PUB-TBE	19.1	10.3	175/ 201
TBE-DHT	19.1	10.2	174/ 200
DHT-AMA	19.1	10.2	174/ 200

NOTE

The preceding are exact values for the as-
sumed conditions.

**BEECHCRAFT Baron B55
TC-371, TC-502 thru TC-1607**

**Section V
Performance**

Enter the graph for Descent at 11,500 feet to the descent line, and enter again at 3965 feet to the descent line, and read:

$$\begin{aligned} \text{Time to Descend} &= (23-8) = 15 \text{ min} \\ \text{Fuel Used to Descend} &= (6.9-2.2) = 4.7 \text{ gal} \\ \text{Descent Distance} &= (72-24) = 48 \text{ NM} \end{aligned}$$

Time and fuel used were calculated at Recommended Cruise Power - 24 in. Hg. 2300 RPM as follows:

$$\text{Time} = \frac{\text{Distance}}{\text{Ground Speed}}$$

$$\text{Fuel Used} = (\text{Time}) (\text{Total Fuel Flow})$$

Results are:

ROUTE SEGMENT	DISTANCE NM	EST GROUND SPEED KTS/MPH	TIME AT CRUISE ALTITUDE HRS: MIN	FUEL USED FOR CRUISE GAL
DEN-COS	*42	203/234	: 12	4.2
COS-PUB	40	201/231	: 12	4.0
PUB-TBE	74	159/183	: 28	9.4
TBE-DHT	87	163/188	: 32	10.6
DHT-AMA	*17	165/190	: 06	2.0

*Distance required to climb or descend has been subtracted from segment distance.

Section V
Performance

BEEHCRAFT Baron B55
TC-371, TC-502 thru TC-1607

TIME - FUEL - DISTANCE

ITEM	TIME HRS: MINS	FUEL GAL	DISTANCE NM
Start, Runup, Taxi and Take- off	0:00	3.3	0
Climb	0:06	3.2	13
Cruise	1:30	30.2	260
Descent	0:15	4.7	48
Total	1:51	41.4	321

Total Flight Time: 1 hour, 51 minutes

Block Speed: $321 \text{ NM} \div 1 \text{ hour, 51 minutes} = 174 \text{ kts/200 mph}$

Reserve Fuel: (45 minutes at Economy Cruise Power):

Enter the cruise power settings table for Economy Cruise Power at 11,500 feet for ISA (assume ISA Fuel Flow Rate).

Fuel Flow Per Engine = 9.0 gal/hr

Total Fuel Flow = 18.0 gal/hr (108 lb/hr)

Reserve Fuel = (45 min) (108 lb/hr) = 81 lbs (13.5 gal)

Total Fuel = $41.4 + 13.5 = 54.9$ gallons

The estimated landing weight is determined by subtracting the fuel required for the flight from the ramp weight:

Assumed ramp weight = 5121 lbs

Estimated fuel from DEN to AMA = 41.4 gal (248 lbs)

Estimated landing weight = 5121 - 248 = 4873 lbs

Examples have been provided on the performance graphs. The above conditions have been used throughout. Rate of climb was determined for the initial cruise altitude conditions.

Enter the graph for Landing Distance at 25°C, 3965 feet pressure altitude, 4873 pounds and 9.5 kts headwind component:

Ground Roll	1500 ft
Total Distance over 50 ft Obstacle	2100 ft
Approach Speed	87 kts/100 mph

Enter the graph for Climb-Balked Landing at 25°C, 3965 feet pressure altitude and 4873 pounds:

Rate-of-Climb	570 ft/min
Climb Gradient	6.0%

**COMMENTS PERTINENT TO THE USE OF
PERFORMANCE GRAPHS**

1. The example, in addition to presenting an answer for a particular set of conditions, also presents the order in which the graphs should normally be used, i.e., if the first item in the example is OAT, then enter the graph at the known OAT.
2. The reference lines indicate where to begin following guide lines. Always project to the reference line first, then follow the guide lines to the next known item.
3. Indicated airspeeds (IAS) were obtained by using the Airspeed Calibration-Normal System.
4. The associated conditions define the specific conditions from which performance parameters have been determined. They are not intended to be used as instructions, however, performance values determined from charts can only be achieved if specified conditions exist.
5. The full amount of usable fuel is available for all approved flight conditions.

AIRSPEED CALIBRATION - NORMAL SYSTEM

EXAMPLE

NOTE: INDICATED AIRSPEED ASSUMES ZERO INSTRUMENT ERROR

IAS
 FLAPS
 DOWN

80 KNOTS (92 MPH)

DOWN

CAS

79 KNOTS (91 MPH)

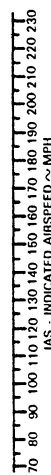
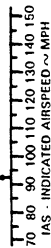
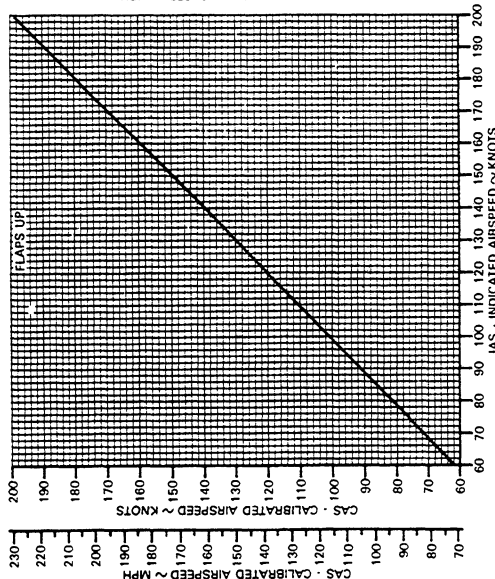
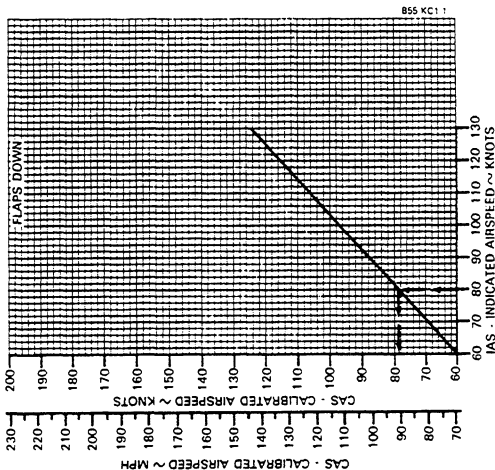

Section V
Performance

BEECHCRAFT Baron B55
TC-371, TC-502 thru TC-1607

ALTIMETER CORRECTION - NORMAL SYSTEM

NOTE
INDICATED ALTITUDE AND INDICATED AIRSPEED
ASSUME ZERO INSTRUMENT ERROR

EXAMPLE

80 KNOTS (92 MPH)
DOWN
5000 FT

IAS
FLAPS
INDICATED PRESSURE
ALTITUDE

ALTIMETER CORRECTION 14 FT
ACTUAL PRESSURE (5000 14) 4986 FT
ALTITUDE

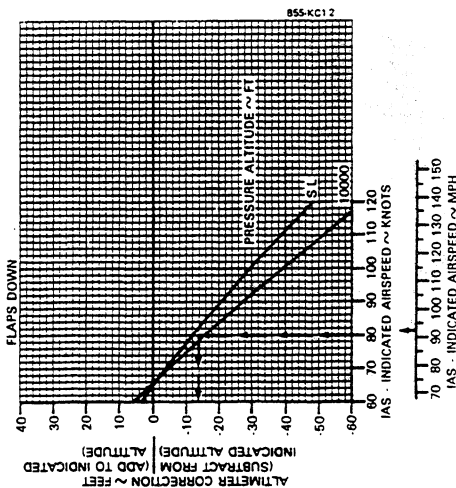
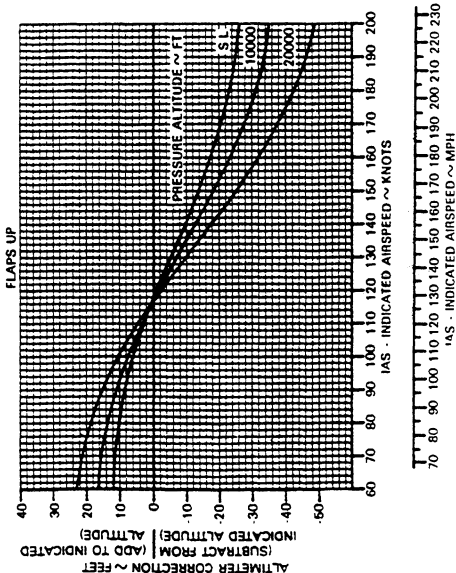

855-KC12

AIRSPEED CALIBRATION - ALTERNATE SYSTEM

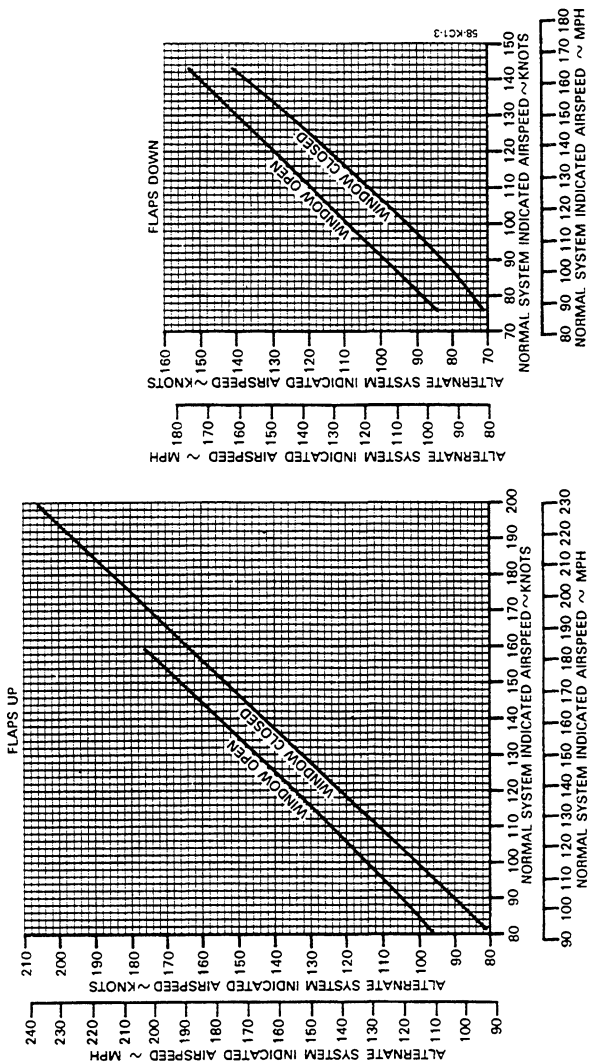

ALTIMETER CORRECTION - ALTERNATE SYSTEM

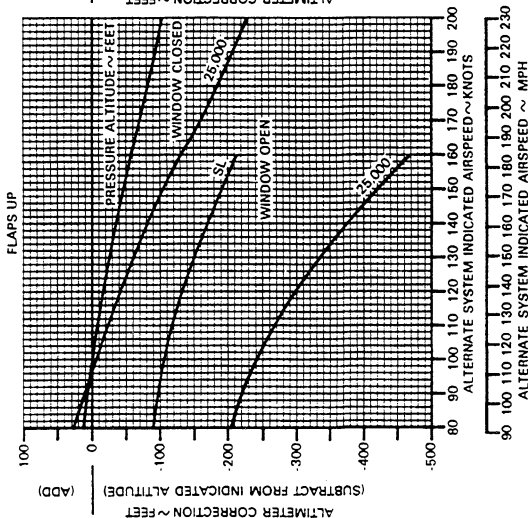
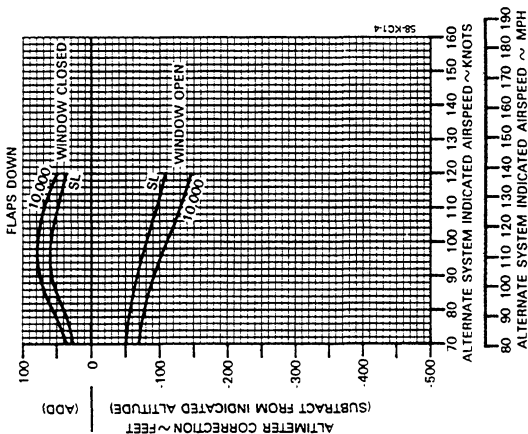

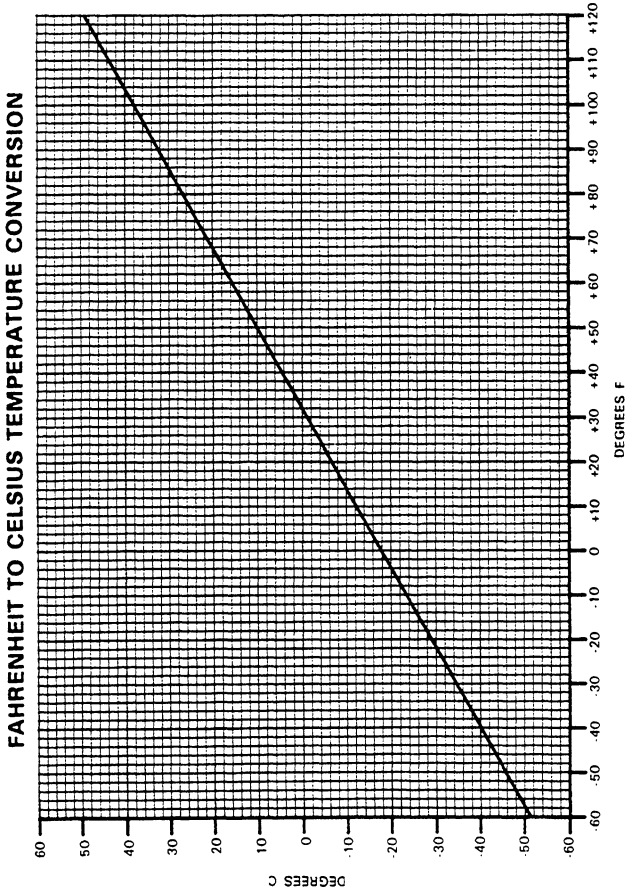

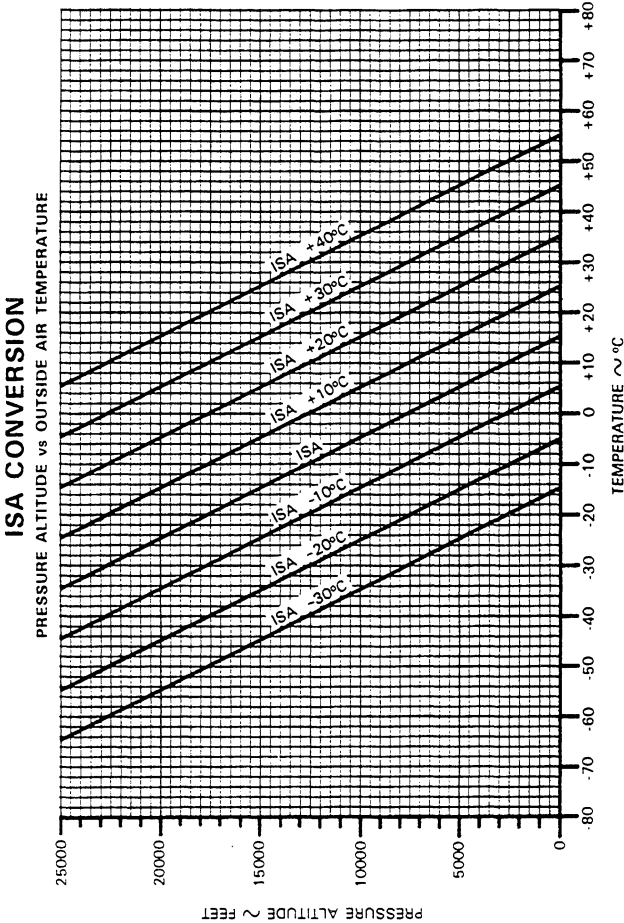

MANIFOLD PRESSURE vs RPM

EXAMPLE
 ENGINE SPEED 2300 RPM
 MANIFOLD PRESSURE 19.1 IN. HG
 WITHIN RECOMMENDED LIMITS

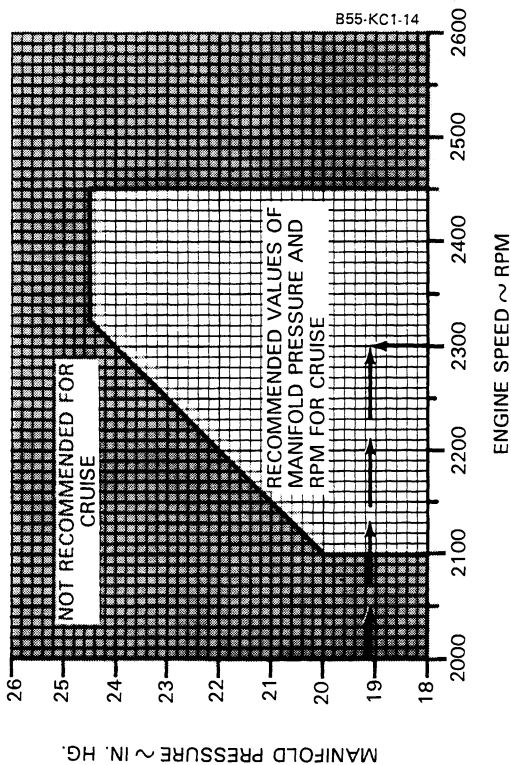

Section V Performance

BEECHCRAFT Baron B55 TC-371, TC-502 thru TC-1607

TAKE-OFF WEIGHT

TO ACHIEVE POSITIVE SINGLE ENGINE
RATE-OF-CLIMB AT LIFT-OFF

ASSOCIATED CONDITIONS

AIRPLANE AIRBORNE
POWER TAKE-OFF AT 2625 RPM
FLAPS UP
LANDING GEAR DOWN
INOPERATIVE PROPELLER FEATHERED

EXAMPLE

PRESSURE ALTITUDE 5650 FT
OAT 15°C

TAKE-OFF WEIGHT 4550 LBS

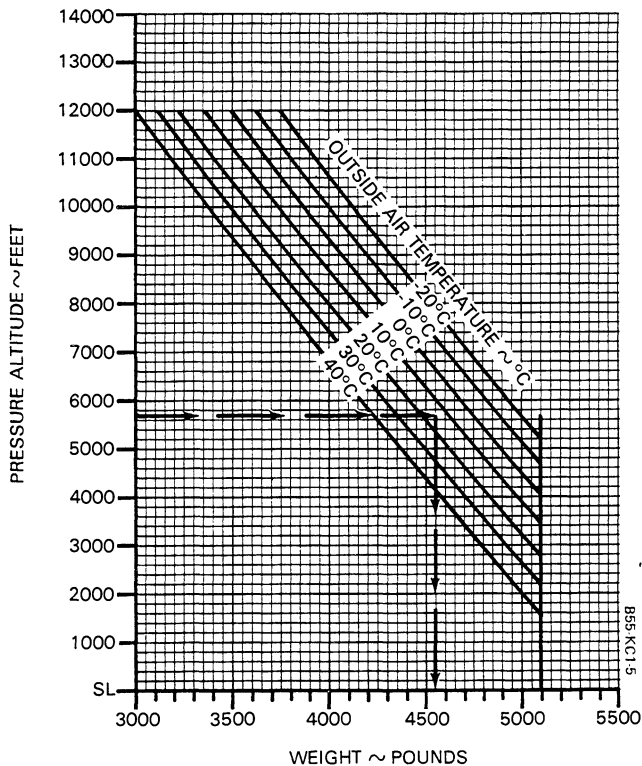

STALL SPEEDS - POWER IDLE

EXAMPLE
 WEIGHT 4550 LBS
 FLAPS UP
 ANGLE OF BANK 30
 STALL SPEED CAS 82 KTS
 IAS 80 KTS
 94 MPH
 92 MPH

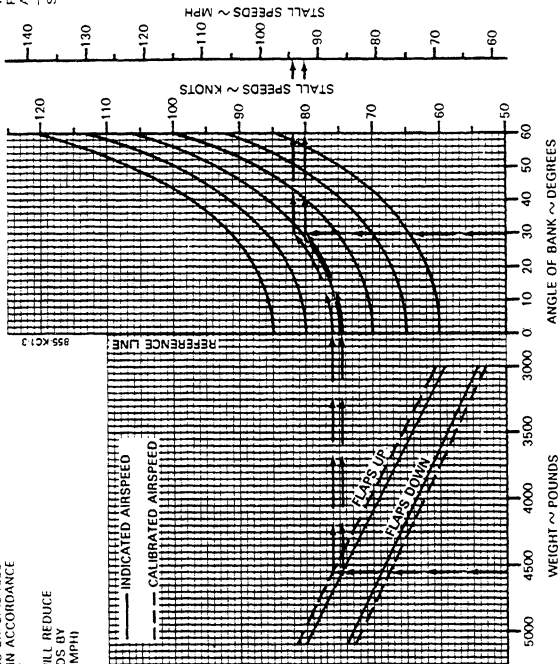

NOTES

- 1 THE MAXIMUM ALTITUDE LOSS EXPERIENCED WHILE CONDUCTING STALLS IN ACCORDANCE WITH CARB 3120 WAS 350 FT
- 2 ZERO THRUST CONDITIONS WILL REDUCE THE POWER OFF STALL SPEEDS BY APPROXIMATELY 4 KNOTS (5 MPH)

WIND COMPONENTS

Demonstrated Crosswind Component is 22 kts

EXAMPLE:

WIND SPEED	20 KTS
ANGLE BETWEEN WIND DIRECTION AND FLIGHT PATH	50°
HEADWIND COMPONENT	13 KTS
CROSSWIND COMPONENT	15 KTS

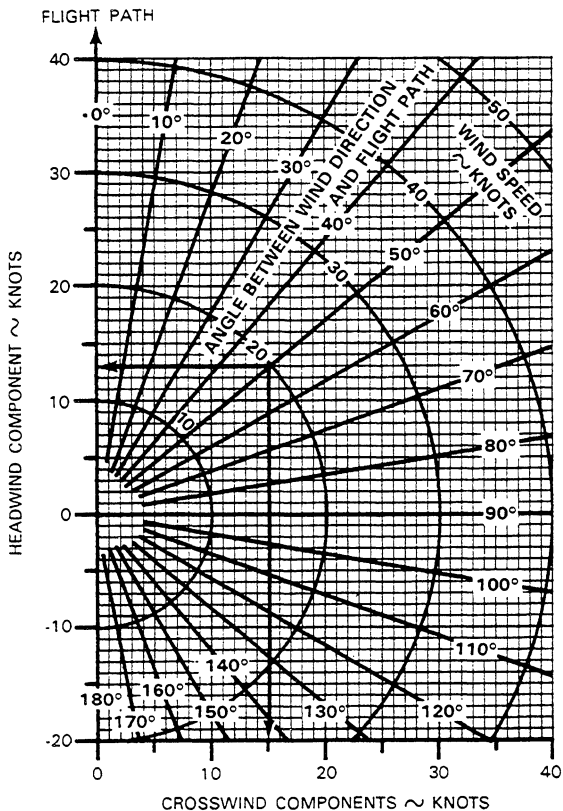

**BEECHCRAFT Baron B55
TC-371, TC-502 thru TC-1607**

**Section V
Performance**

TAKE-OFF DISTANCE

ASSOCIATED CONDITIONS:
 TAKE-OFF AT 2625 RPM
 POWER LEAN TO APPROPRIATE
 MIXTURE FUEL FLOW
 UP (10°)
 FLAPS RETRACT AFTER POSITIVE
 LANDING GEAR CLIMB ESTABLISHED
 COWL FLAPS OPEN
 RUNWAY PAVED, LEVEL, DRY SURFACE

EXAMPLE:
 PRESSURE ALTITUDE 15°C
 TAKE-OFF WEIGHT 5650 FT
 HEAD WIND COMPONENT 5100 LBS
 9.5 KTS
 GROUND ROLL 2000 FT
 TOTAL DISTANCE OVER 3200 FT
 50 FT OBSTACLE
 TAKE-OFF SPEED AT 84 KTS/97 MPH
 LIFT-OFF 91 KTS/105 MPH
 50 FT

LIFT-OFF SPEED (ALL WEIGHTS)
 84 KNOTS/97 MPH
 50 FT SPEED (ALL WEIGHTS)
 91 KNOTS/105 MPH

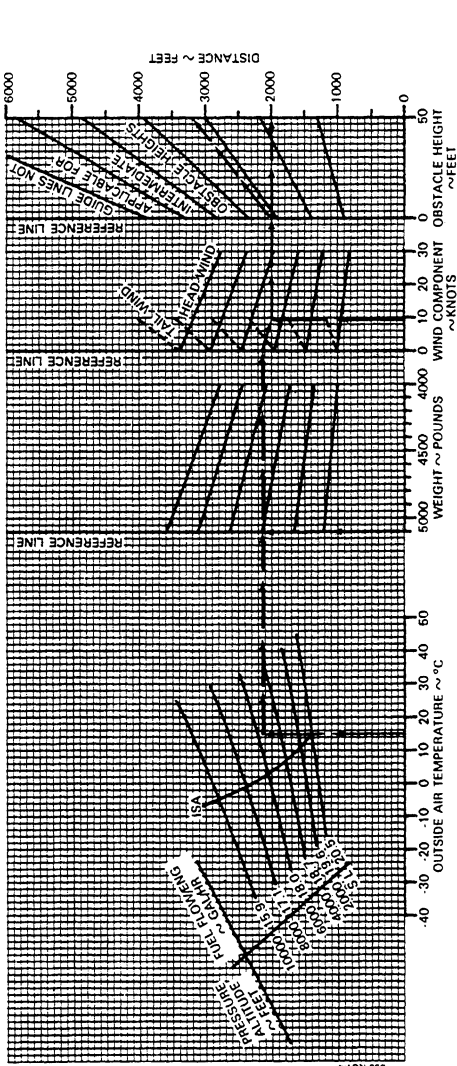

855-KC14

Section V Performance

BEECHCRAFT Baron B55 TC-371, TC-502 thru TC-1607

ACCELERATE - STOP DISTANCE

ASSOCIATED CONDITIONS

- POWER
 - 1 TAKE OFF POWER AT 2625 RPM SET BEFORE BRAKE RELEASE
 - 2 ENGINES IDLE AT DECISION SPEED
- MIXTURE
 - LEAN TO APPROPRIATE FUEL FLOW
- FLAPS
 - UP (0°)
- RUNWAY
 - PAVED, LEVEL, DRY SURFACE
- COWL FLAPS
 - OPEN

EXAMPLE

- OAT 15°C
- PRESSURE ALTITUDE 5650 FT
- TAKE-OFF WEIGHT 5100 LBS
- HEAD WIND 9.5 KTS
- ACCELERATE AND STOP DISTANCE 4100 FT
- IAS DECISION SPEED 84 KTS/97 MPH

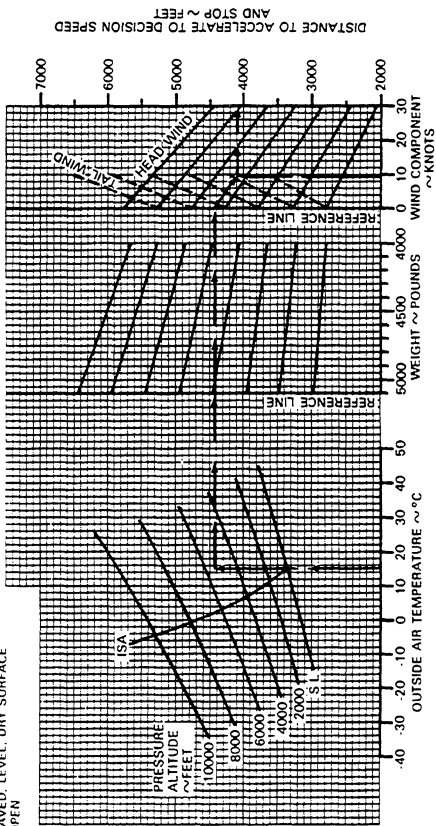

DISTANCE TO ACCELERATE TO DECISION SPEED AND STOP ~ FEET

855-KC1-12

ACCELERATE - GO DISTANCE

ASSOCIATED CONDITIONS:

TAKE-OFF POWER AT 2625 RPM SET
 BEFORE BRAKE RELEASE
 UP TO APPROPRIATE FUEL FLOW
 RETRACT AFTER LIFT-OFF
 PAVED, LEVEL, DRY SURFACE
 COWL FLAPS OPEN

LIFT-OFF SPEED (ALL WEIGHTS)
 84 KNOTS/97 MPH
 50 FT SPEED (ALL WEIGHTS)
 91 KNOTS/105 MPH

EXAMPLE:

PRESSURE ALTITUDE
 TAKE-OFF WEIGHT
 HEAD WIND COMPONENT
 15°C
 5650 FT
 4550 LBS
 9.5 KTS
 1800 FT
 7100 FT

NOTES:

- DISTANCES ASSUME AN ENGINE FAILURE AT LIFT OFF AND PROPELLER IMMEDIATELY FEATHERED.
- WEIGHTS IN SHADED AREA MAY NOT PROVIDE POSITIVE ONE ENGINE INOPERATIVE CLIMB. REFER TO TAKE-OFF WEIGHT GRAPH FOR MAXIMUM WEIGHT AT WHICH THE ACCELERATE GO PROCEDURE SHOULD BE ATTEMPTED.

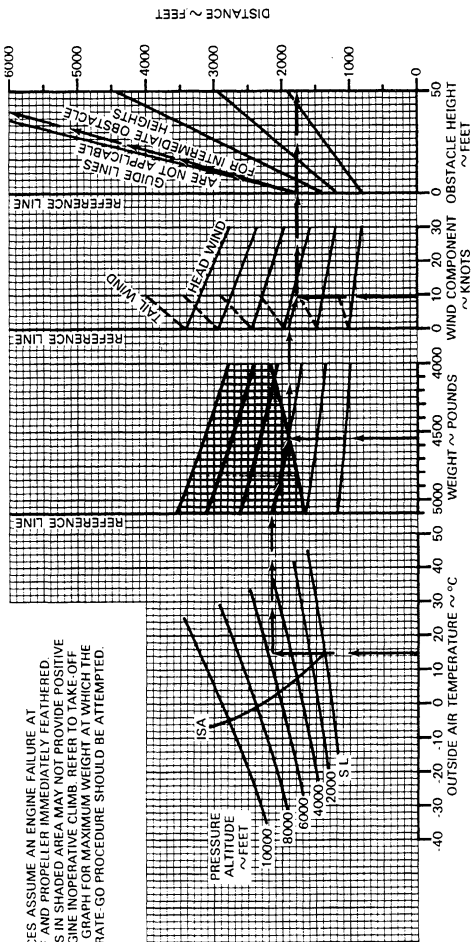

Section V Performance

BEECHCRAFT Baron B55 TC-371, TC-502 thru TC-1607

CLIMB - TWO ENGINE

CLIMB SPEED 107 KNOTS (ALL WEIGHTS)
123 MPH

ASSOCIATED CONDITIONS:

- POWER UP
- LANDING GEAR UP
- COWL FLAPS OPEN
- MIXTURE LEAN TO APPROPRIATE
- FUEL FLOW
- MAXIMUM CONTINUOUS AT 2625 RPM

EXAMPLE:

OAT -5°C
PRESSURE ALTITUDE 11500 FT
WEIGHT 5081 LBS
RATE-OF-CLIMB 720 FT/MIN
CLIMB GRADIENT 5.5%

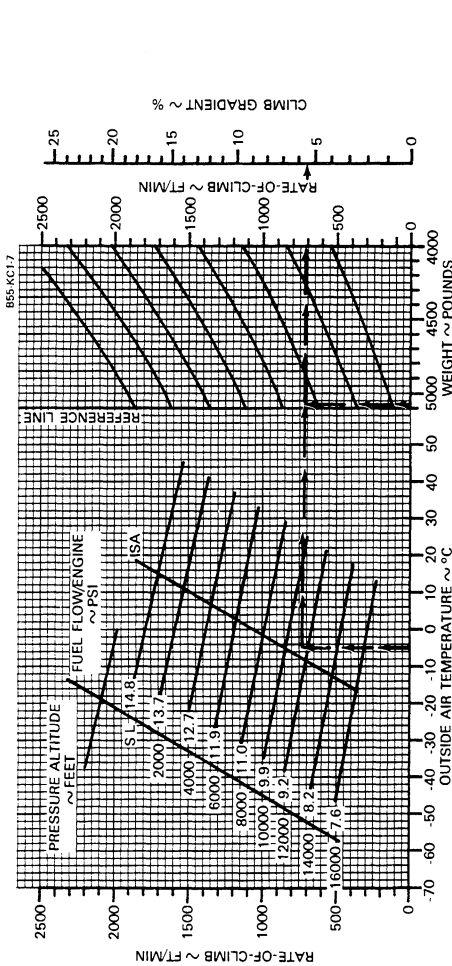

TAKE-OFF CLIMB GRADIENT - ONE ENGINE INOPERATIVE

ASSOCIATED CONDITIONS:

POWER UP
LANDING GEAR UP
FLAPS UP
INOPERATIVE PROPELLER FEATHERED
COWL FLAPS OPEN

CLIMB SPEED (ALL WEIGHTS)

91 KNOTS/105 MPH

EXAMPLE:

OAT 15°C
PRESSURE ALTITUDE 5650 FT
WEIGHT 4550 LBS
GRADIENT OF CLIMB 2.2%
CLIMB SPEED 91 KTS/105 MPH

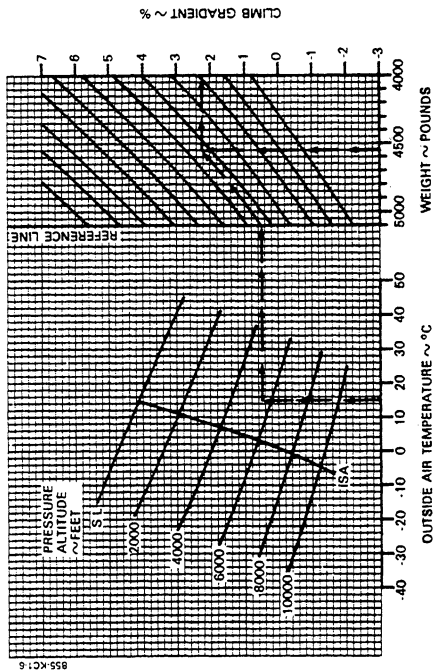

Section V Performance

BEECHCRAFT Baron B55 TC-371, TC-502 thru TC-1607

TIME, FUEL AND DISTANCE TO CLIMB

ASSOCIATED CONDITIONS

POWER 25 IN H_g OR FULL THROTTLE
 2500 RPM
 FUEL DENSITY 6.0 LB/GAL
 MIXTURE LEAN TO APPROPRIATE FUEL FLOW
 COOL FLAPS AS REQUIRED

CLIMB SPEED ~ 122 KNOTS
 140 MPH

EXAMPLE

OAT AT TAKE-OFF 15 C
 OAT AT CRUISE 5 C
 AIRPORT PRESSURE ALTITUDE 5650 FT
 CRUISE PRESSURE ALTITUDE 11500 FT
 INITIAL CLIMB WEIGHT 5100 LBS
 TIME TO CLIMB 10-4 6 MIN
 FUEL TO CLIMB 57-25 3.2 GAL
 DISTANCE TO CLIMB 22-9 13 NM

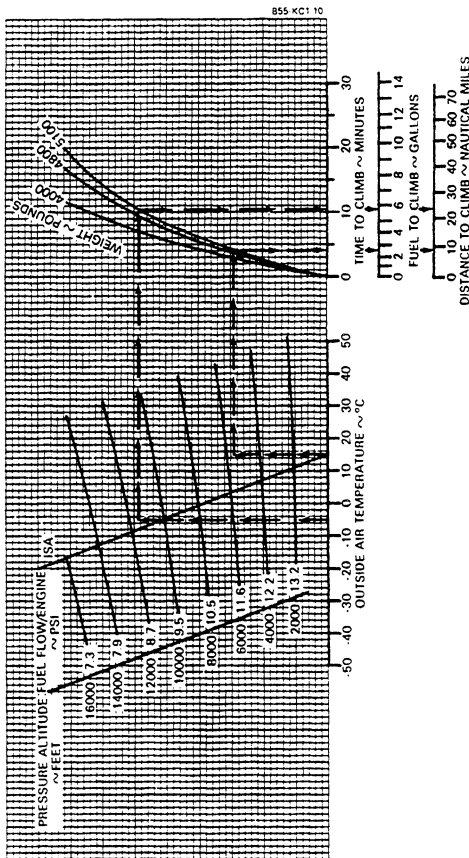

CLIMB - ONE ENGINE INOPERATIVE

ASSOCIATED CONDITIONS:

- POWER UP
- LANDING GEAR UP
- FLAPS FULL
- PROPPELLER FEATHERED
- CONTOUR FLAPS OPEN
- MIXTURE LEAN TO APPROPRIATE
- FUEL FLOW

CLIMB SPEED 100 KNOTS (ALL WEIGHTS)

115 MPH

MAXIMUM CONTINUOUS AT 2625 RPM

UP

FEATHERED

PROPPELLER

FLAPS

MIXTURE

LEAN TO APPROPRIATE

FUEL FLOW

EXAMPLE:

- OAT 15 C
- PRESSURE ALTITUDE 5650 FT
- WEIGHT 4550 LBS
- RATE OF CLIMB 230 FT/MIN
- CLIMB GRADIENT 2.3%

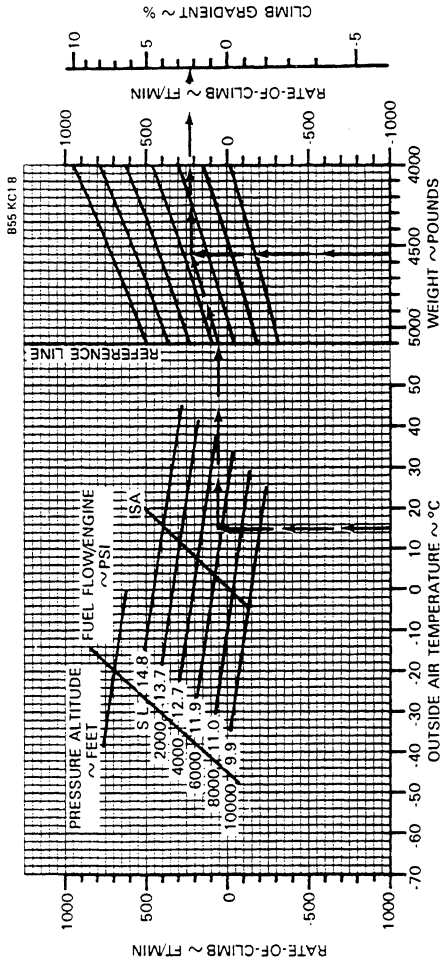

Section V
Performance

BEECHCRAFT Baron B55
TC-371, TC-502 thru TC-1607

SERVICE CEILING - ONE ENGINE INOPERATIVE

ASSOCIATED CONDITIONS

POWER MAXIMUM CONTINUOUS
AT 2625 RPM
LANDING GEAR UP
INOPERATIVE PROPELLER FEATHERED
FLAPS UP

EXAMPLE

OAT 5 C
WEIGHT 4550 LBS
SERVICE CEILING 9000 FT

NOTE
SERVICE CEILING IS THE PRESSURE ALTITUDE WHERE
AIRPLANE HAS CAPABILITY OF CLIMBING 50 FT MINUTE
WITH ONE PROPELLER FEATHERED

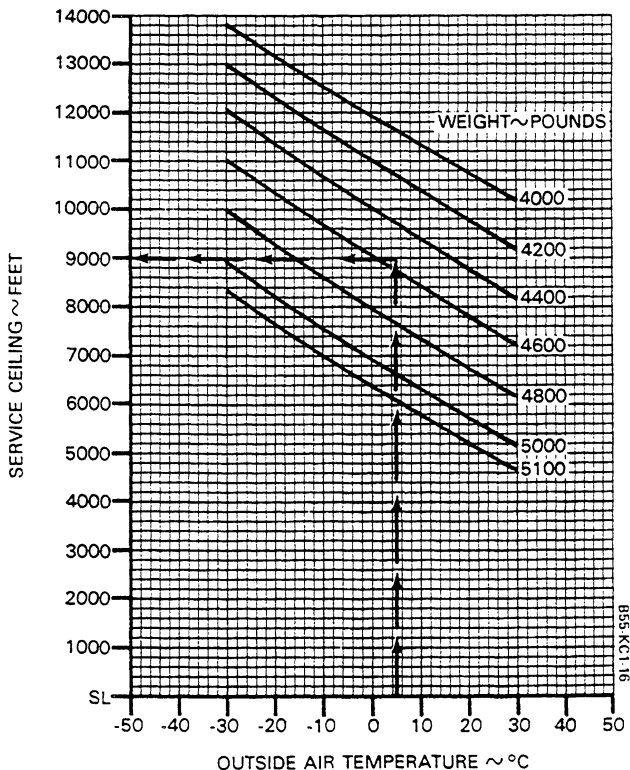

CRUISE SPEEDS

ASSOCIATED CONDITIONS

AVERAGE CRUISE WEIGHT 4900 LBS
 TEMPERATURE STANDARD DAY (ISA)

EXAMPLE

PRESSURE ALTITUDE 11500 FT
 POWER SETTING FULL THROTTLE
 2300 RPM
 TRUE AIRSPEED 174 KNOTS
 200 MPH

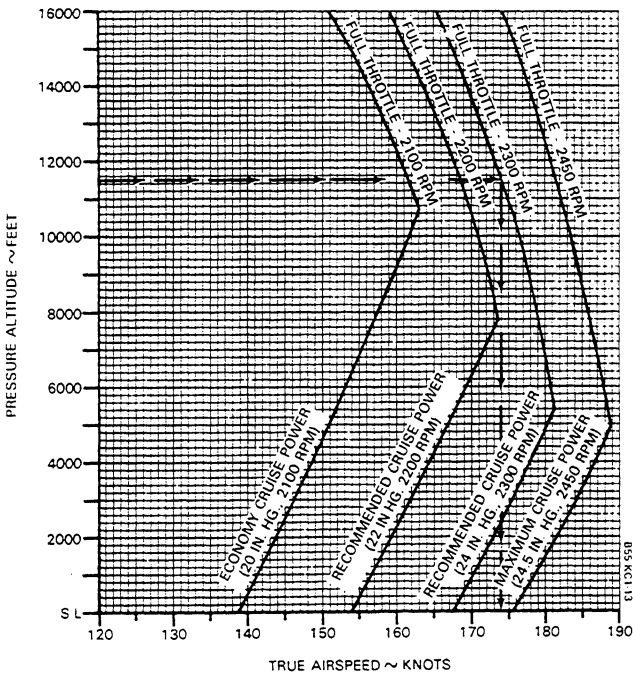

Section V
Performance

BEEHCRAFT Baron B55
TC-371, TC-502 thru TC-1607

FUEL FLOW vs BRAKE HORSEPOWER

EXAMPLE

FUEL FLOW/ENGINE CONDITION	10.2 GAL/HR LEVEL FLIGHT CRUISE LEAN
BRAKE HORSEPOWER PER ENGINE	144 HP

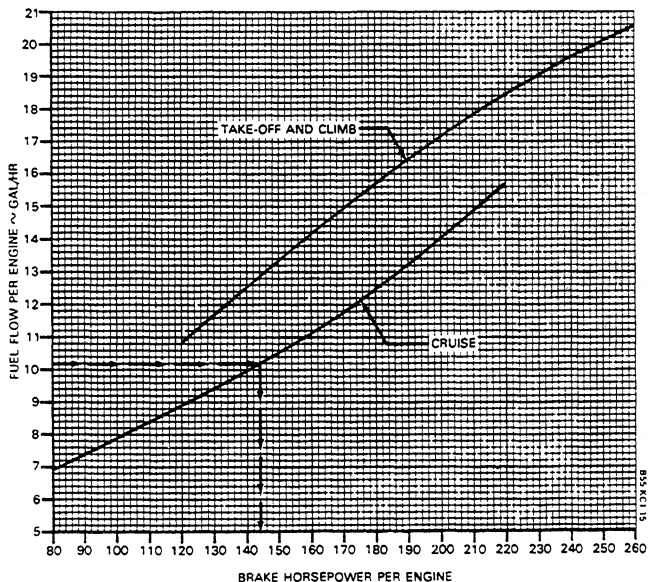

FUEL FLOW vs FUEL PRESSURE

EXAMPLE

FUEL FLOW/ENGINE	10.2 GAL/HR
FUEL PRESSURE	5.8 PSI

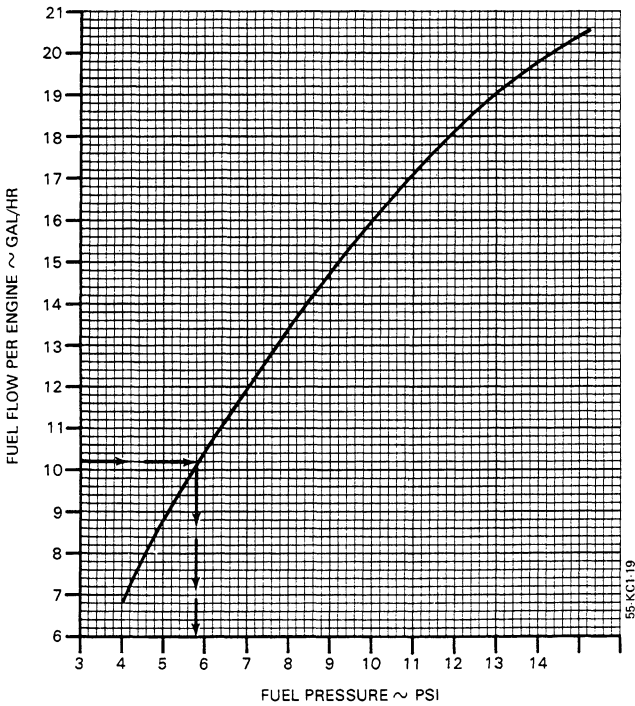

CRUISE POWER SETTINGS

MAXIMUM CRUISE POWER
24.5 IN. HG. 2450 RPM (OR FULL THROTTLE)
4900 LBS.

PRESS ALT.	ISA -36°F (-20°C)						STANDARD DAY (ISA)						ISA +36°F (+20°C)											
	IOAT		ENGINE SPEED	MAN. PRESS	FUEL FLOW/ ENGINE	TAS CAS	IOAT		ENGINE SPEED	MAN. PRESS	FUEL FLOW/ ENGINE	TAS CAS	IOAT		ENGINE SPEED	MAN. PRESS	FUEL FLOW/ ENGINE	TAS CAS						
	°F	°C	RPM	IN HG	PSI	GPH	KTS	°F	°C	RPM	IN HG	PSI	GPH	KTS	°F	°C	RPM	IN HG	PSI	GPH	KTS			
SL	28	-2	2450	24.5	8.6	14.2	174	180	64	18	2450	24.5	8.2	13.7	176	175	100	38	2450	24.5	7.8	13.1	177	171
2000	21	-6	2450	24.5	9.0	14.7	180	181	58	14	2450	24.5	8.6	14.2	182	176	94	34	2450	24.5	8.2	13.7	183	172
4000	15	-10	2450	24.5	9.3	15.2	185	181	51	10	2450	24.5	8.9	14.6	187	176	87	31	2450	24.5	8.4	14.0	188	172
6000	8	-14	2450	23.3	8.9	14.6	186	177	44	7	2450	23.3	8.4	14.0	188	172	80	27	2450	23.3	8.1	13.8	189	167
8000	0	-18	2450	21.6	8.0	13.4	184	170	37	3	2450	21.6	7.8	12.9	186	165	73	23	2480	21.6	7.3	12.4	187	161
10000	-7	-22	2450	20.1	7.2	12.3	182	163	29	-2	2480	20.1	6.9	11.9	184	168	65	19	2480	20.1	6.7	11.5	186	154
12000	-14	-26	2450	18.7	6.5	11.4	179	165	22	-6	2450	18.7	6.4	11.1	181	161	58	14	2460	18.7	6.2	10.8	182	146
14000	-21	-30	2450	17.2	6.1	10.7	177	149	15	-10	2450	17.2	5.9	10.4	178	144	51	10	2480	17.2	5.7	10.1	178	139
16000	-28	-34	2450	16.1	5.7	10.0	173	142	7	-14	2480	16.1	5.6	9.8	174	137	43	6	2480	16.1	5.4	9.5	174	131

NOTES:

1. FULL THROTTLE MANIFOLD PRESSURE SETTINGS ARE APPROXIMATE
2. SHADED AREA REPRESENTS OPERATION WITH FULL THROTTLE

CRUISE POWER SETTINGS

RECOMMENDED CRUISE POWER
24.0 IN. HG. 2300 RPM (OR FULL THROTTLE)
4900 LBS.

PRESS ALT.	ISA -36°F (-20°C)										STANDARD DAY (ISA)										ISA +36°F (+20°C)									
	IOAT		ENGINE SPEED	MAN. PRESS	IN HG	PSI	FUEL FLOW/ ENGINE	TAS	CAS	KTS	IOAT	ENGINE SPEED	MAN. PRESS	IN HG	PSI	FUEL FLOW/ ENGINE	TAS	CAS	KTS	IOAT	ENGINE SPEED	MAN. PRESS	IN HG	PSI	FUEL FLOW/ ENGINE	TAS	CAS	KTS		
	°F	°C	RPM				GPH				°F	°C				GPH				°F	°C				GPH					
SL	28	-2	2300	24.0	24.0	7.2	12.3	166	172	64	18	2300	24.0	24.0	6.9	11.9	168	168	100	38	2300	24.0	24.0	6.7	11.6	169	163	163		
2000	21	-6	2300	24.0	24.0	7.5	12.7	171	172	57	14	2300	24.0	24.0	7.2	12.3	173	168	93	34	2300	24.0	24.0	6.9	11.8	174	163	163		
4000	14	-10	2300	24.0	24.0	7.8	13.1	176	173	50	10	2300	24.0	24.0	7.4	12.6	178	168	86	30	2300	24.0	24.0	7.1	12.2	179	163	163		
6000	7	-14	2300	23.4	23.4	7.7	13.0	174	170	43	6	2300	23.4	23.4	7.3	12.5	181	165	79	25	2300	23.4	23.4	7.0	12.1	182	161	161		
8000	1	-18	2300	21.7	21.7	7.6	12.6	177	163	36	2	2300	21.7	21.7	6.7	11.6	179	169	72	12	2300	21.7	21.7	6.5	11.3	180	164	164		
10000	-7	-23	2300	20.2	20.2	8.5	11.7	175	157	29	-2	2300	20.2	20.2	6.3	10.9	176	167	65	18	2300	20.2	20.2	6.1	10.6	177	147	147		
12000	-16	-28	2300	18.7	18.7	8.9	10.5	173	149	21	-6	2300	18.7	18.7	5.8	10.2	173	145	58	14	2300	18.7	18.7	5.7	10.0	174	145	145		
14000	-22	-30	2300	17.3	17.3	8.7	9.9	170	142	14	-10	2300	17.3	17.3	6.5	9.7	170	137	50	10	2300	17.3	17.3	6.3	9.4	170	133	133		
16000	-29	-34	2300	16.0	16.0	8.3	9.3	165	135	7	-14	2300	16.0	16.0	5.7	9.1	165	129	43	6	2300	16.0	16.0	6.1	8.9	165	124	124		

- NOTES:
1. FULL THROTTLE MANIFOLD PRESSURE SETTINGS ARE APPROXIMATE
2. SHADED AREA REPRESENTS OPERATION WITH FULL THROTTLE

CRUISE POWER SETTINGS

RECOMMENDED CRUISE POWER
22.0 IN. HG. 2200 RPM (OR FULL THROTTLE)
4900 LBS.

PRESS ALT.	ISA -36°F (-20°C)						STANDARD DAY (ISA)						ISA +36°F (+20°C)											
	IOAT		ENGINE SPEED	MAN. PRESS	FUEL FLOW/ ENGINE	TAS	CAS	KTS	IOAT	ENGINE SPEED	MAN. PRESS	FUEL FLOW/ ENGINE	TAS	CAS	KTS	IOAT	ENGINE SPEED	MAN. PRESS	FUEL FLOW/ ENGINE	TAS	CAS	KTS		
	°F	°C	RPM	IN HG	PSI	GPH	KTS			°F	°C	RPM	IN HG	PSI			GPH	KTS	°F	°C	RPM		IN HG	PSI
SL	27	-3	2200	22.0	5.9	10.3	152	158	63	17	2200	22.0	5.7	10.0	154	154	99	37	2200	22.0	5.6	9.8	155	150
2000	20	-7	2200	22.0	6.1	10.6	157	158	56	14	2200	22.0	5.9	10.3	159	155	92	34	2200	22.0	5.7	10.0	160	150
4000	13	-10	2200	22.0	6.3	10.9	162	159	49	10	2200	22.0	6.1	10.6	165	155	86	30	2200	22.0	5.9	10.3	165	151
6000	7	-14	2200	22.0	6.8	11.1	167	159	43	6	2200	22.0	6.2	10.8	169	155	79	26	2200	22.0	6.0	10.5	170	151
8000	0	-18	2200	21.8	6.5	11.2	171	168	36	2	2200	21.8	6.3	10.9	173	164	72	22	2200	21.9	6.1	10.8	174	150
10000	-6	-22	2200	20.2	6.1	10.6	169	161	26	-2	2200	20.2	5.9	10.3	171	147	68	18	2200	20.2	6.7	10.0	172	143
12000	-15	-26	2200	18.7	5.7	10.0	166	144	21	-6	2200	18.7	5.5	9.7	168	140	57	14	2200	19.7	5.4	9.5	168	135
14000	-22	-30	2200	17.3	5.4	9.4	161	136	14	-10	2200	17.3	5.2	9.1	164	132	50	10	2200	17.3	5.1	8.9	163	127
16000	-30	-34	2200	16.0	5.1	8.9	157	128	6	-14	2200	16.0	4.9	8.7	159	125	42	6	2200	16.0	4.9	8.5	168	118

NOTES:
1. FULL THROTTLE MANIFOLD PRESSURE SETTINGS ARE APPROXIMATE
2. SHADED AREA REPRESENTS OPERATION WITH FULL THROTTLE

CRUISE POWER SETTINGS

ECONOMY CRUISE POWER
20.0 IN. HG. 2100 RPM (OR FULL THROTTLE)
4900 LBS.

PRESS ALT.	ISA -36°F (-20°C)										STANDARD DAY (ISA)										ISA +36°F (+20°C)									
	IOAT		ENGINE SPEED	MAN. PRESS	FUEL FLOW/ ENGINE	TAS	CAS	IOAT	ENGINE SPEED	MAN. PRESS	FUEL FLOW/ ENGINE	TAS	CAS	IOAT	ENGINE SPEED	MAN. PRESS	FUEL FLOW/ ENGINE	TAS	CAS											
	°F	°C																		°F	°C	°F	°C	°F	°C	°F	°C	°F	°C	°F
SL	26	-3	2100	20.0	4.9	8.7	138	143	62	17	2100	20.0	4.8	8.5	139	139	98	37	2100	20.0	4.7	8.3	139	134						
2000	19	-7	2100	20.0	5.1	8.9	143	144	55	13	2100	20.0	4.9	8.7	144	139	92	33	2100	20.0	4.8	8.5	144	135						
4000	13	-11	2100	20.0	5.2	9.1	148	144	49	9	2100	20.0	5.1	8.9	148	140	85	29	2100	20.0	4.9	8.7	148	135						
6000	6	-15	2100	20.0	5.3	9.3	152	145	42	5	2100	20.0	5.2	9.1	153	140	78	25	2100	20.0	5.1	8.9	153	135						
8000	-1	-18	2100	20.0	5.4	9.5	157	145	35	2	2100	20.0	5.3	9.3	157	140	71	22	2100	20.0	5.2	9.0	158	135						
10000	-8	-22	2100	20.0	5.5	9.7	161	144	28	-2	2100	20.0	5.4	9.4	162	139	64	18	2100	20.0	5.2	9.2	162	135						
12000	-15	-28	2100	18.7	5.3	9.3	160	139	21	-6	2100	18.7	5.2	9.1	161	134	57	14	2100	18.7	5.1	8.9	160	129						
14000	-23	-30	2100	17.3	5.0	8.8	156	132	13	-10	2100	17.3	4.9	8.6	156	126	49	10	2100	17.3	4.8	8.5	156	121						
16000	-30	-34	2100	16.0	4.8	8.5	152	124	6	-14	2100	16.0	4.7	8.3	151	118	42	6	2100	16.0	4.6	8.1	148	112						

NOTES:
1. FULL THROTTLE MANIFOLD PRESSURE SETTINGS ARE APPROXIMATE
2. SHADED AREA REPRESENTS OPERATION WITH FULL THROTTLE

Section V Performance

BEECHCRAFT Baron B55 TC-371, TC-502 thru TC-1607

RANGE PROFILE - 100 GALLONS

ASSOCIATED CONDITIONS

WEIGHT 5121 LBS BEFORE ENGINE START
 FUEL AVIATION GASOLINE
 FUEL DENSITY 6.0 LBS/GAL
 INITIAL FUEL LOADING 100 U.S. GAL (600 LBS)

STANDARD DAY (ISA)

NOTE
 RANGE INCLUDES START, TAXI, CLIMB AND DESCENT
 WITH 15 MINUTES RESERVE FUEL AT ECONOMY CRUISE

EXAMPLE

PRESSURE ALTITUDE 11500 FT
 FULL THROTTLE
 POWER SETTING 2300 RPM
 RANGE 680 N M

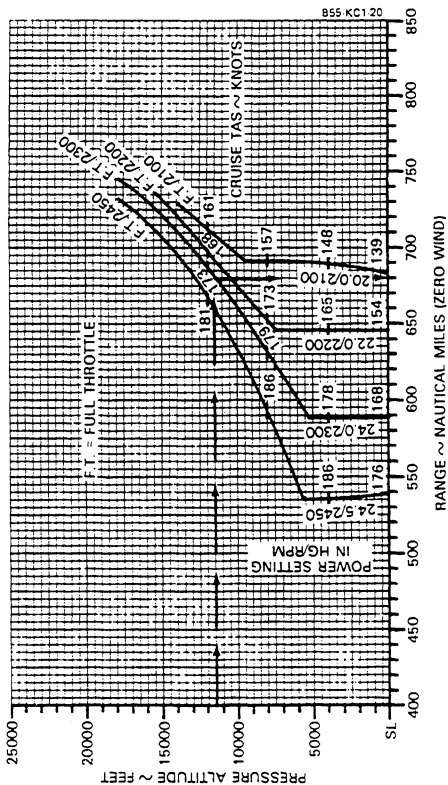

ENDURANCE PROFILE - 100 GALLONS

ASSOCIATED CONDITIONS:

WEIGHT 5121 LBS BEFORE ENGINE START
 FUEL AVIATION GASOLINE
 FUEL DENSITY 6.0 LBS/GAL
 INITIAL LOADING 100 U.S. GAL (1600 LBS)

STANDARD DAY (ISA)

EXAMPLE:
 PRESSURE ALTITUDE 11500 FT
 FULL THROTTLE
 POWER SETTING 2300 RPM

ENDURANCE
 3 HRS 95 MINS
 3 HRS 58 MINS

NOTE:
 ENDURANCE INCLUDES START, TAXI, CLIMB AND DESCENT
 WITH 45 MINUTES RESERVE FUEL AT ECONOMY CRUISE

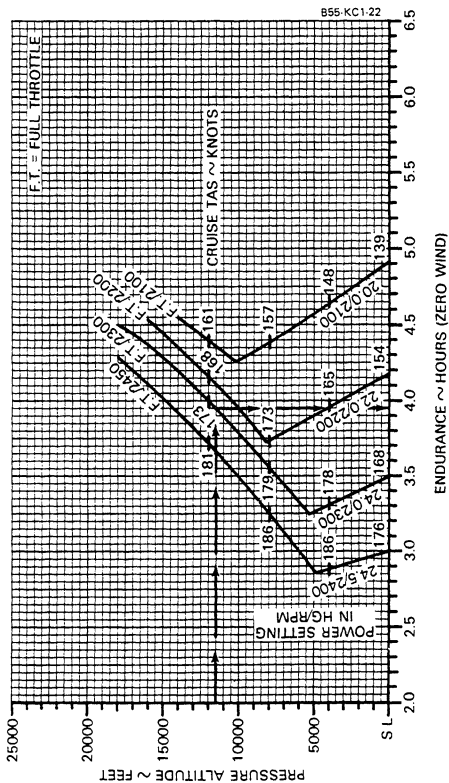

Section V Performance

BEECHCRAFT Baron B55 TC-371, TC-502 thru TC-1607

RANGE PROFILE - 136 GALLONS

ASSOCIATED CONDITIONS:

WEIGHT 5121 LBS BEFORE ENGINE START
 FUEL AVIATION GASOLINE
 FUEL DENSITY 6.0 LBS./GAL
 INITIAL FUEL LOADING 136 U.S. GAL (816 LBS)

STANDARD DAY (ISA)

NOTE
 RANGE INCLUDES START, TAXI, CLIMB AND DESCENT
 WITH 45 MINUTES RESERVE FUEL AT ECONOMY CRUISE

EXAMPLE:

PRESSURE ALTITUDE 11500 FEET
 POWER SETTING FULL THROTTLE
 RANGE 2300 RPM
 980 N.M.

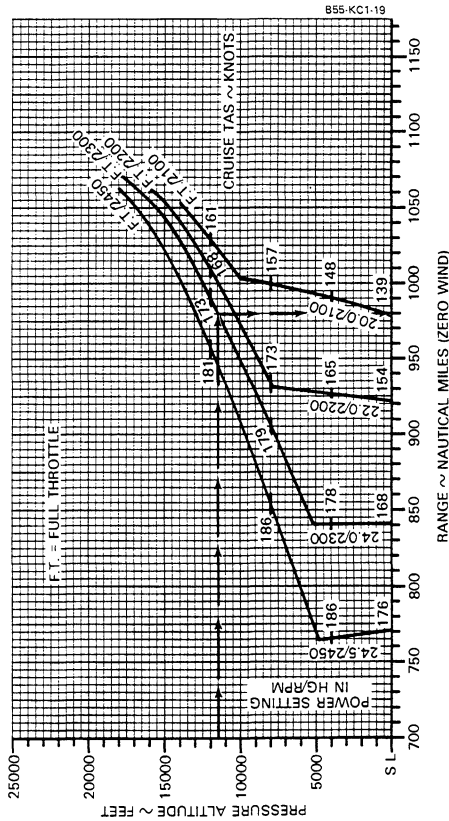

ENDURANCE PROFILE - 136 GALLONS

ASSOCIATED CONDITIONS

WEIGHT 5121 LBS BEFORE ENGINE START
 FUEL AVIATION GASOLINE
 FUEL DENSITY 6.0 LBS/GAL
 INITIAL LOADING 136 U.S. GAL (816 LBS)

STANDARD DAY (ISA)

EXAMPLE
 PRESSURE ALTITUDE 11500 FEET
 POWER SETTING FULL THROTTLE
 ENDURANCE 2300 MPH
 5.65 HRS.
 5 HRS. 39 MIN

NOTE
 ENDURANCE INCLUDES START, TAXI, CLIMB AND DESCENT
 WITH 45 MINUTES RESERVE FUEL AT ECONOMY CRUISE

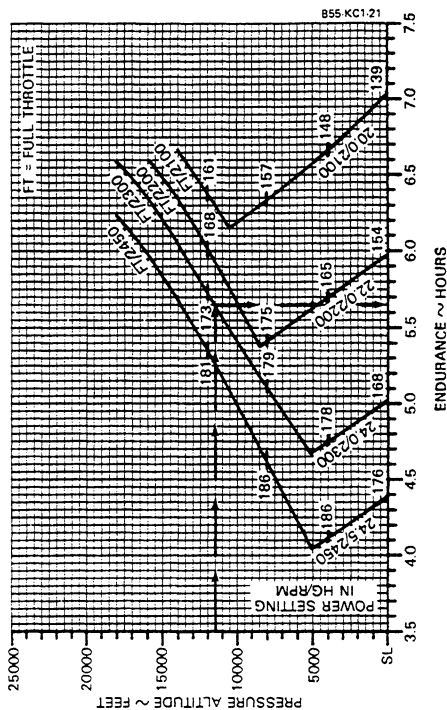

Section V Performance

BEECHCRAFT Baron B55 TC-371, TC-502 thru TC-1607

EXAMPLE

FUEL AVAILABLE FOR HOLDING 200 LBS
 PRESSURE ALT 5000 FT
 HOLDING TIME 1.8 HRS
 1 HR. 48 MIN

HOLDING TIME

ASSOCIATED CONDITIONS:

POWER SETTING 20.0 IN. HG. OR
 FULL THROTTLE
 2100 RPM

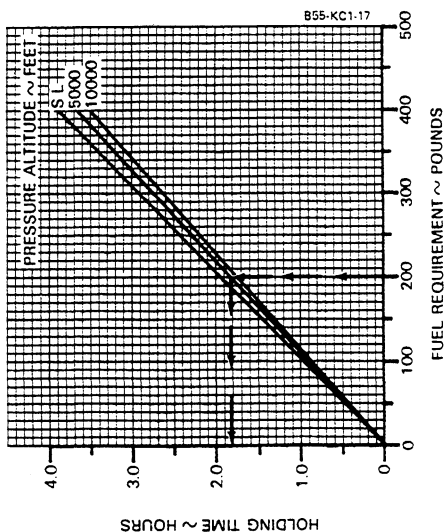

**BEECHCRAFT Baron B55
TC-371, TC-502 thru TC-1607**

**Section V
Performance**

TIME, FUEL AND DISTANCE TO DESCEND

DESCENT SPEED 172 KIAS
198 MPH

ASSOCIATED CONDITIONS

POWER AS REQUIRED TO
MAINTAIN 500 FT/MIN
RATE OF DESCENT
LANDING GEAR UP
FLAPS UP

EXAMPLE

INITIAL ALTITUDE 11500 FT
FINAL ALTITUDE 3965 FT
TIME TO DESCEND 23 : 8 : 15 MIN
FUEL TO DESCEND 69 : 2 : 47 GAL
DISTANCE TO DESCEND 72 : 24 : 48 N.M.

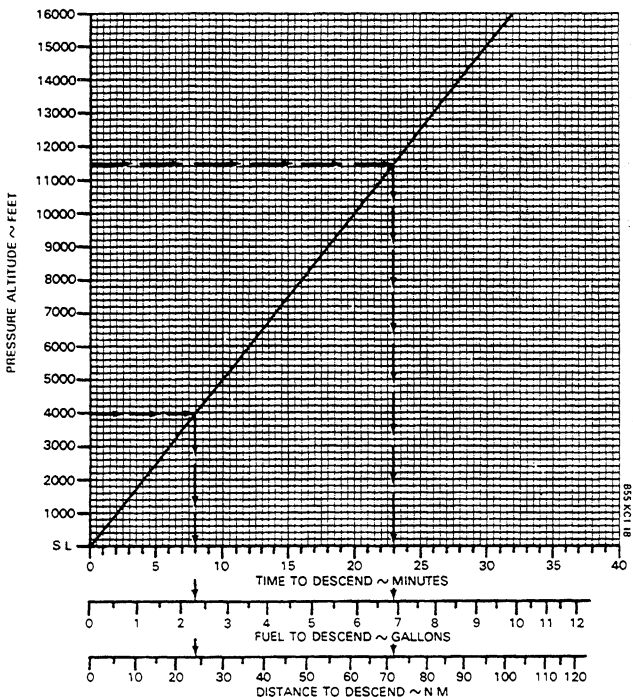

Section V Performance

BEECHCRAFT Baron B55 TC-371, TC-502 thru TC-1607

CLIMB-BALKED LANDING

CLIMB SPEED 90 KNOTS (ALL WEIGHTS)
104 MPH

ASSOCIATED CONDITIONS

- POWER DOWN
- FLAPS DOWN
- LANDING GEAR DOWN TO APPROPRIATE MIXTURE
- FUEL FLOW

EXAMPLE

- OAT 25°C (77°F)
- PRESSURE ALTITUDE 3965 FT
- WEIGHT 4873 LBS
- RATE-OF-CLIMB 570 FT/MIN
- CLIMB GRADIENT 6%

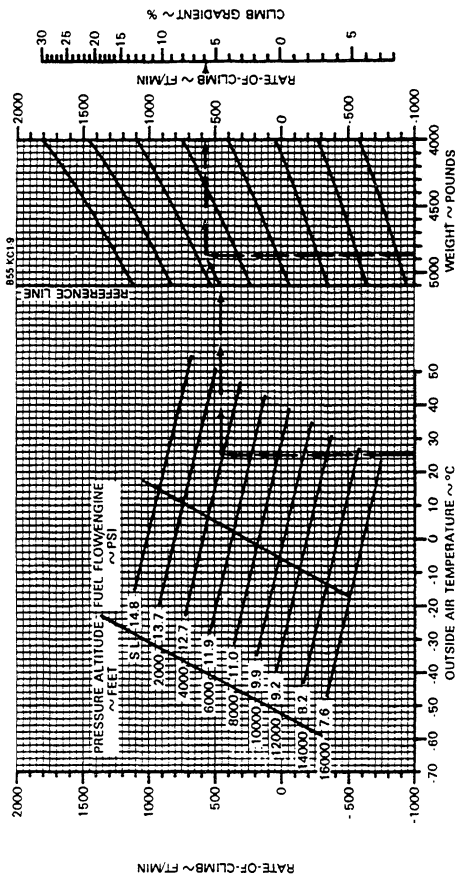

BEECHCRAFT Baron B55 TC-371, TC-502 thru TC-1607

Section V Performance

LANDING DISTANCE

ASSOCIATED CONDITIONS

- POWER RETAILED TO MAINTAIN 800 FT MIN ON FINAL APPROACH
- FLAPS DOWN
- LANDING GEAR DOWN, LEVEL, DRY RUNWAY SURFACE
- APPROACH SPEED IAS AS TABULATED
- BRKING MAXIMUM

WEIGHT ~ LBS	SPEED AT 50 FEET	
	KTS	MPH
5100	90	104
4800	87	100
4600	85	98
4400	84	97
4200	81	93

EXAMPLE

- OAT 25 C
- PRESSURE ALTITUDE 3995 FT
- WIND COMPONENT 187 KTS
- WIND COMPONENT 9.5 KTS
- GROUND ROLL 1500 FT
- TOTAL OVER 50 FT 2100 FT
- OBSTACLE APPROACH 87 KTS, 100 MPH

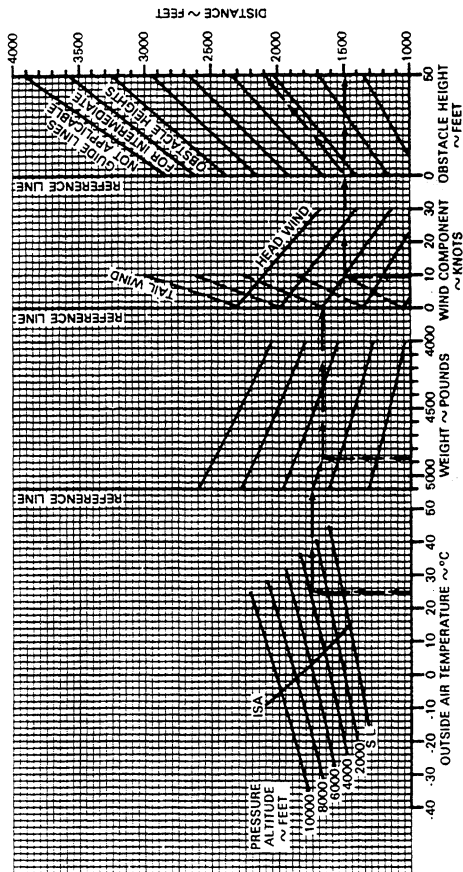

955 KC1 23

INTENTIONALLY LEFT BLANK

SECTION VI

WEIGHT AND BALANCE/ EQUIPMENT LIST

TABLE OF CONTENTS

<i>SUBJECT</i>	<i>PAGE</i>
Weighing Instructions	6-3
Basic Empty Weight and Balance Form	6-5
Weight and Balance Record	6-7
Loading Instructions	6-9
Seating, Baggage and Equipment	
Arrangements	6-9
Moment Limits vs Weight Table	6-11 - 6-18
Moment Limits vs Weight Graph	6-14
Computing Procedure	6-19
Sample Weight and Balance Loading Form .	6-21
Weight and Balance Loading Form	6-22
Useful Load Weights and Moments	6-23 - 6-24
Occupants	6-23
Baggage	6-25
Cargo	6-26 - 6-27
Usable Fuel	6-28
Oil	6-28
Airplane Papers (furnished with individual airplane)	

INTENTIONALLY LEFT BLANK

WEIGHING INSTRUCTIONS

Periodic weighing of the airplane may be required to keep the Basic Empty Weight current. All changes to the airplane affecting weight and balance are the responsibility of the airplane's operator.

1. Three jack points are provided for weighing: two on the wing front spar at Fuselage Station 83.1 and one on the aft fuselage at Fuselage Station 271.0.
2. Fuel should be drained preparatory to weighing. Tanks are drained from the regular drain ports with the airplane in static ground attitude. When tanks are drained, 5.7 pounds of undrainable fuel remain in the airplane at Fuselage Station 81.6. The remainder of the unusable fuel to be added to a drained system is 35.3 pounds at Fuselage Station 78.6
3. Engine oil must be at the full level or completely drained. Total engine oil when full is 45 pounds at Fuselage Station 43.
4. To determine airplane configuration at time of weighing, installed equipment is checked against the airplane equipment list or superseding forms. All installed equipment must be in its proper place during weighing.
5. The airplane must be in a longitudinally level attitude at the time of weighing. Leveling screws are located on the left side of the fuselage at Fuselage Station 152.25 (approximately). Level attitude is determined with a plumb bob.
6. Measurement of the reaction arms for a wheel weighing is made using a steel measuring tape. Measurements are taken, with the airplane level on the scales, from the reference (a plumb bob dropped from the center of either main jack point) to the axle

center line of the main gear and then to the nose wheel axle center line. The main wheel axle center line is best located by stretching a string across from one main wheel to the other. All measurements are to be taken with the tape level with the hangar floor and parallel to the fuselage center line. The locations of the wheel reactions will be approximately at Fuselage Station 96.7 for main wheels and Fuselage Station 12.7 for the nose wheel.

7. Jack point weighings are accomplished by placing scales at the jack points specified in step 1 above. Since the center of gravity of the airplane is forward of Fuselage Station 83.1, the tail reaction of the airplane will be in an up direction. This can be measured on regular scales by placing ballast of approximately 200 pounds on the scales and attached to the aft weighing point by cable of adjustable length. The up reaction will then be total ballast weight minus the scale reading and is entered in the weighing form as a negative quantity.
8. Weighing should always be made in an enclosed area which is free from air currents. The scales used should be properly calibrated and certified.

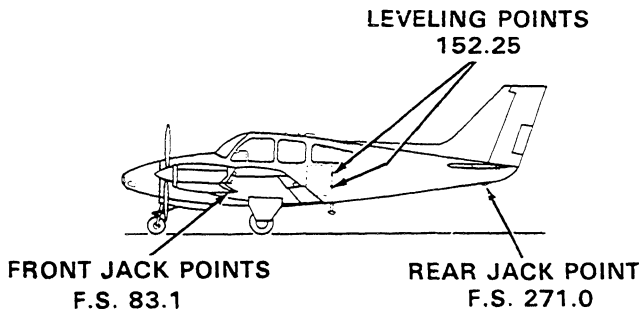

BASIC EMPTY WEIGHT AND BALANCE

BARON B55 SER. NO. _____ REG. NO. _____ DATE _____
STRUT POSITION - NOSE MAIN JACK POINT LOCATION PREPARED BY
 EXTENDED 11.8 96 FORWARD 83.1 Company _____
 COMPRESSED 13.1 97 AFT 271.0 Signature _____

REACTION WHEEL - JACK POINTS	SCALE READING	TARE	NET WEIGHT	ARM	MOMENT
LEFT MAIN					
RIGHT MAIN					
NOSE OR TAIL					
TOTAL (AS WEIGHED)					
Space below provided for additions and subtractions to as weighed condition					
EMPTY WEIGHT (DRY)			45	-	1935
ENGINE OIL			41	79	3239
UNUSABLE FUEL					
BASIC EMPTY WEIGHT					

NOTE

Each new airplane is delivered with a completed sample loading, empty weight and center of gravity, and equipment list, all pertinent to that specific airplane. It is the owner's responsibility to ensure that changes in equipment are reflected in a new weight and balance and in an addendum to the equipment list. There are many ways of doing this; it is suggested that a running tally of equipment changes and their effect on empty weight and c.g. is a suitable means for meeting both requirements.

The current equipment list and empty weight and c.g. information must be retained with the airplane when it changes ownership. Beech Aircraft Corporation cannot maintain this information; the current status is known only to the owner. If these papers become lost, the FAA will require that the airplane be reweighed to establish the empty weight and c.g. and that an inventory of installed equipment be conducted to create a new equipment list.

WEIGHT AND BALANCE RECORD

SERIAL NO. _____ REGISTRATION NO. _____ PAGE NO. 1

DATE	ITEM NO.		DESCRIPTION OF ARTICLE OR CHANGE	WEIGHT CHANGE ADDED (+) OR REMOVED (-)			RUNNING BASIC EMPTY WEIGHT	
	IN	OUT		WT (LBS)	ARM (IN.)	MOM $\frac{MOM}{100}$	WT (LBS)	MOM $\frac{MOM}{100}$

Section VI
Wt and Bal/Equip List

BEEHCRAFT Baron B55
TC-371, TC-502 thru TC-1607

WEIGHT AND BALANCE RECORD

2

PAGE NO.

REGISTRATION NO.

SERIAL NO.

DATE	ITEM NO.		DESCRIPTION OF ARTICLE OR CHANGE	WEIGHT CHANGE ADDED (+) OR REMOVED (-)			RUNNING BASIC EMPTY WEIGHT	
	IN	OUT		WT (LBS)	ARM (IN.)	MOM 100	WT (LBS)	MOM 100

LOADING INSTRUCTIONS

It is the responsibility of the airplane operator to ensure that the airplane is properly loaded. At the time of delivery, Beech Aircraft Corporation provides the necessary weight and balance data to compute individual loadings. All subsequent changes in airplane weight and balance are the responsibility of the airplane owner and/or operator.

The empty weight and moment of the airplane at the time of delivery are shown on the airplane Empty Weight and Balance form. Useful load items which may be loaded into the airplane are shown on the Useful Load Weight and Moment tables. The minimum and maximum moments are indicated on the Moment Limits vs Weight table. These moments correspond to the forward and aft center of gravity flight limits for a particular weight. All moments are divided by 100 to simplify computations.

SEATING, BAGGAGE AND EQUIPMENT ARRANGEMENTS

(TC-371, TC-502 thru TC-1298)

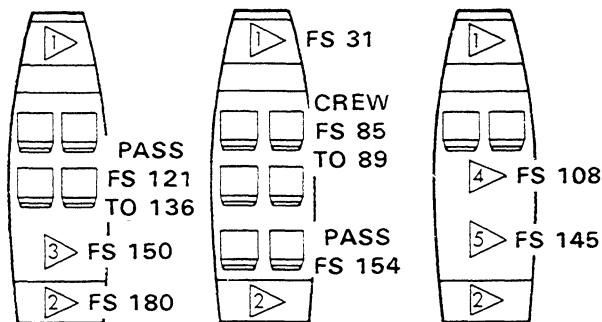

SEATING, BAGGAGE AND EQUIPMENT
ARRANGEMENTS
(TC-1299 thru TC-1607)

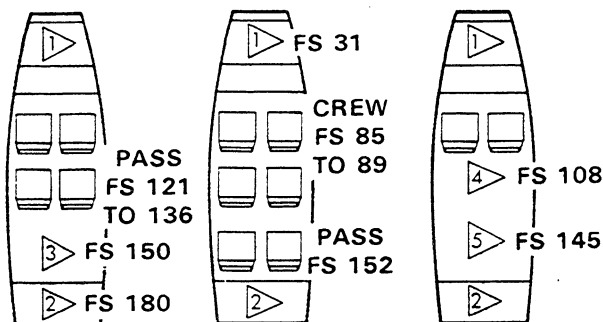

1. MAXIMUM WEIGHT 270 POUNDS (TC-371, TC-502 thru TC-954) OR 300 POUNDS (TC-955 thru TC-1607) INCLUDING EQUIPMENT AND BAGGAGE.
2. MAXIMUM WEIGHT 120 POUNDS INCLUDING EQUIPMENT AND BAGGAGE.
3. MAXIMUM WEIGHT 400 POUNDS INCLUDING EQUIPMENT AND BAGGAGE WITH 5th and 6th SEATS REMOVED OR STOWED.
4. MAXIMUM WEIGHT 200 POUNDS FORWARD OF REAR SPAR INCLUDING EQUIPMENT AND CARGO WITH 3rd and 4th SEATS REMOVED.
5. MAXIMUM WEIGHT 400 POUNDS AFT OF REAR SPAR INCLUDING EQUIPMENT AND CARGO WITH 3rd, 4th, 5th and 6th SEATS REMOVED.

ALL CARGO MUST BE SECURED WITH APPROVED CARGO RETENTION SYSTEMS.

MOMENT LIMITS vs WEIGHT
(TC-371, TC-502 thru TC-954)

Moment limits are based on the following weight and center of gravity limit data (landing gear down).

WEIGHT CONDITION	FORWARD CG LIMIT	AFT CG LIMIT
5000 lb. (B55 max. take-off or landing)	80.0	86.0
4990 lb. (B55A max. take-off or landing)	80.0	86.0
3800 lb. or less	74.0	86.0
Weight	<u>Minimum Moment</u> 100	<u>Maximum Moment</u> 100
3200	2368	2752
3225	2387	2774
3250	2405	2795
3275	2424	2817
3300	2442	2838
3325	2461	2860
3350	2479	2881
3375	2498	2903
3400	2516	2924
3425	2535	2946
3450	2553	2967
3475	2572	2989
3500	2590	3010
3525	2609	3032
3550	2627	3053
3575	2646	3075

MOMENT LIMITS vs WEIGHT (Continued)

Weight	<u>Minimum Moment</u> 100	<u>Maximum Moment</u> 100
3600	2664	3096
3625	2683	3118
3650	2701	3139
3675	2720	3161
3700	2738	3182
3725	2757	3204
3750	2775	3225
3775	2794	3247
3800	2812	3268
3825	2836	3290
3850	2859	3311
3875	2882	3333
3900	2906	3354
3925	2929	3376
3950	2953	3397
3975	2976	3419
4000	3000	3440
4025	3024	3462
4050	3048	3483
4075	3072	3505
4100	3096	3526
4125	3120	3548
4150	3144	3569
4175	3168	3591
4200	3192	3612
4225	3216	3634
4250	3241	3655
4275	3265	3677
4300	3290	3698

MOMENT LIMITS vs WEIGHT (Continued)

Weight	Minimum <u>Moment</u> 100	Maximum <u>Moment</u> 100
4325	3314	3720
4350	3339	3741
4375	3363	3763
4400	3388	3784
4425	3413	3806
4450	3438	3827
4475	3463	3849
4500	3488	3870
4525	3513	3892
4550	3538	3913
4575	3563	3935
4600	3588	3956
4625	3613	3978
4650	3639	3999
4675	3664	4021
4700	3690	4042
4725	3715	4064
4750	3741	4085
4775	3766	4107
4800	3792	4128
4825	3818	4150
4850	3844	4171
4875	3870	4193
4900	3896	4214
4925	3922	4236
4950	3948	4257
4975	3974	4279
4990	3990	4291
5000	4000	4300

Section VI
Wt and Bal/Equip List

BEECHCRAFT Baron B55
TC-371, TC-502 thru TC-1607

Baron B55 and B55A
MOMENT LIMITS vs WEIGHT

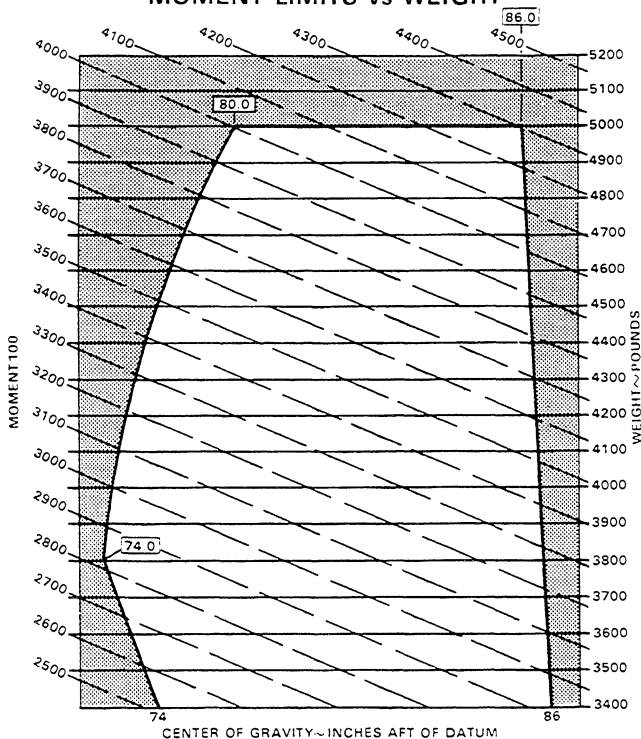

ENVELOPE BASED ON THE FOLLOWING WEIGHT AND CENTER OF GRAVITY LIMIT DATA (LANDING GEAR DOWN):

B55

WEIGHT CONDITION	FORWARD CG. LIMIT	AFT CG. LIMIT
5000 LB (MAX TAKE-OFF OR LANDING)	80.0	86.0
3800 LB or LESS	74.0	86.0

B55A

WEIGHT CONDITION	FORWARD CG. LIMIT	AFT CG. LIMIT
4990 LB (MAX TAKE-OFF OR LANDING)	80.0	86.0
3800 LB or LESS	74.0	86.0

MOMENT LIMITS vs WEIGHT

(TC-955 thru TC-1607 and prior serials when Kit 55-4014 is installed)

Moment limits are based on the following weight and center of gravity limit data (landing gear down).

WEIGHT CONDITION	FORWARD CG LIMIT	AFT CG LIMIT
5100 lb. (B55 max. take-off or landing)	81.0	86.0
4990 lb. (B55A max. take-off or landing)	79.9	86.0
4740 lb.	77.5	86.0
3800 lb. or less	74.0	86.0
Weight	<u>Minimum Moment</u> 100	<u>Maximum Moment</u> 100
3200	2368	2752
3225	2387	2774
3250	2405	2795
3275	2424	2817
3300	2442	2838
3325	2461	2860
3350	2479	2881
3375	2498	2903
3400	2516	2924
3425	2535	2946
3450	2553	2967
3475	2572	2989
3500	2590	3010
3525	2609	3032
3550	2627	3053
3575	2646	3075

MOMENT LIMITS vs WEIGHT (Continued)

Weight	<u>Minimum Moment</u> 100	<u>Maximum Moment</u> 100
3600	2664	3096
3625	2683	3118
3650	2701	3139
3675	2720	3161
3700	2738	3182
3725	2757	3204
3750	2775	3225
3775	2794	3247
3800	2812	3268
3825	2834	3290
3850	2856	3311
3875	2878	3333
3900	2901	3354
3925	2923	3376
3950	2945	3397
3975	2967	3419
4000	2990	3440
4025	3012	3462
4050	3035	3483
4075	3057	3505
4100	3080	3526
4125	3102	3548
4150	3125	3569
4175	3148	3591
4200	3170	3612
4225	3193	3634
4250	3216	3655
4275	3239	3677
4300	3262	3698
4325	3285	3720
4350	3308	3741

MOMENT LIMITS vs WEIGHT (Continued)

Weight	Minimum Moment	Maximum Moment
	100	100
4375	3331	3763
4400	3354	3784
4425	3377	3806
4450	3401	3827
4475	3424	3849
4500	3447	3870
4525	3471	3892
4550	3494	3913
4575	3517	3935
4600	3541	3956
4625	3564	3978
4650	3588	3999
4675	3612	4021
4700	3635	4042
4725	3659	4064
4750	3686	4085
4775	3717	4107
4800	3748	4128
4825	3779	4150
4850	3810	4171
4875	3842	4193
4900	3873	4214
4925	3905	4236
4950	3937	4257
4975	3969	4279
4990	3988	4291
5000	4001	4300
5025	4033	4322
5050	4066	4343
5075	4098	4365
5100	4131	4386

Baron B55 and B55A
MOMENT LIMITS vs WEIGHT

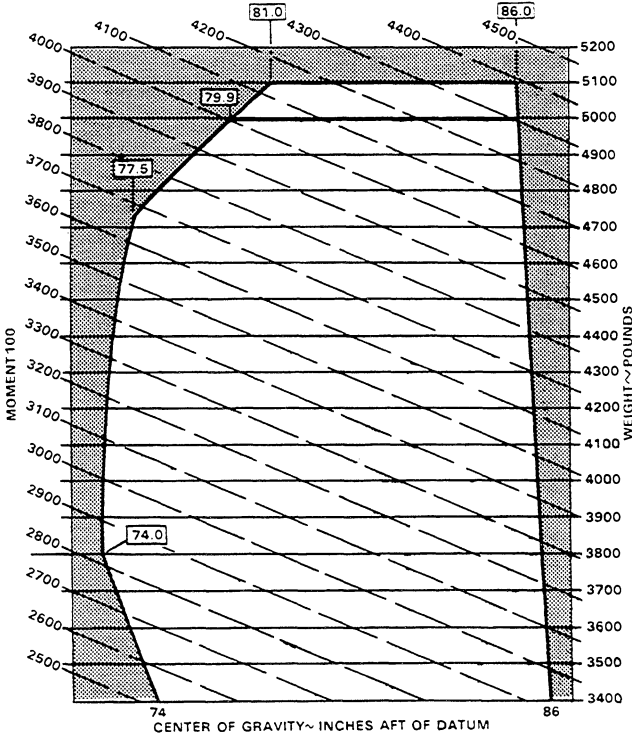

ENVELOPE BASED ON THE FOLLOWING WEIGHT AND CENTER OF GRAVITY LIMIT DATA (LANDING GEAR DOWN)

B55		
WEIGHT CONDITION	FORWARD CG. LIMIT	AFT CG. LIMIT
5100 LB (MAX TAKE-OFF OR LANDING)	81.0	86.0
4740 LB	77.5	86.0
3800 LB or LESS	74.0	86.0

B55A		
WEIGHT CONDITION	FORWARD CG. LIMIT	AFT CG. LIMIT
4990 LB (MAX TAKE-OFF OR LANDING)	79.9	86.0
4740 LB	77.5	86.0
3800 LB or LESS	74.0	86.0

COMPUTING PROCEDURE

1. Record the *Basic Empty Weight and Moment from the Basic Empty Weight and Balance form (or from the latest superseding form) under the Basic Empty Condition block. The moment must be divided by 100 to correspond to Useful Load Weights and Moments tables.
2. Record the weight and corresponding moment from the appropriate table of each of the useful load items (except fuel) to be carried in the airplane.
3. Total the weight column and moment column. The SUB-TOTAL is the Zero Fuel Condition.
4. Determine the weight and corresponding moment for the fuel loading to be used. This fuel loading includes fuel for the flight, plus that required for start, taxi, and take-off. Add the Fuel to Zero Fuel Condition to obtain the SUB-TOTAL Ramp Condition.
5. Subtract the fuel to be used for start and taxi to arrive at the SUB-TOTAL Take-off Condition.
6. Subtract the weight and moment of the fuel in the incremental sequence in which it is to be used from the take-off weight and moment. The Zero Fuel Condition, the Take-Off Condition, and the Landing Condition moment must be within the minimum and maximum moments shown on the Moment Limit vs Weight table for that weight. If the total moment is less than the

minimum moment allowed, useful load items must be shifted aft or forward load items reduced. If the total moment is greater than the maximum moment allowed, useful load items must be shifted forward or aft load items reduced. If the quantity or location of load items is changed, the calculations must be revised and the moments rechecked.

- * On airplanes prior to serial number TC-1403 the Empty Weight (Dry) for the airplane may be converted to Basic Empty Weight by adding the weight and moment for full oil (45 lbs. and 1935 lb. in.) and unusable fuel (41 lbs. and 3239 lb. in.).

The following Sample Loading chart is presented to depict the sample method of computing a load. Weights used DO NOT reflect an actual airplane loading.

WEIGHT AND BALANCE LOADING FORM

BARON B55 DATE _____

SERIAL NO. TC-XXXX REG NO. NXXX

ITEM	WEIGHT	MOM/100
1. BASIC EMPTY CONDITION	3337	2634
2. FRONT SEAT OCCUPANTS	340	290
3. 3rd and 4th SEAT OCCUPANTS	340	412
4. 5th and 6th SEAT OCCUPANTS	170	258
5. NOSE BAGGAGE	78	24
6. REAR BAGGAGE	-	-
7. AFT BAGGAGE	40	72
8. CARGO	-	-
9. SUB TOTAL ZERO FUEL CONDITION	4305	3690
10. FUEL - MAIN (74 GAL) FUEL - AUX (62 GAL)	444 372	333 346
11. SUB TOTAL RAMP CONDITION	5121	4369
12. *LESS FUEL FOR START, TAXI, AND TAKE-OFF	-21	-16
13. SUB TOTAL TAKE-OFF CONDITION	5100	4353
14. LESS FUEL - MAIN (20 GAL)	-120	-90
15. SUB TOTAL	4980	4263
14. LESS FUEL - AUX (62 GAL)	-372	-346
17. SUB TOTAL	4608	3917
18. LESS FUEL - MAIN (30 GAL)	-180	-135
19. LANDING CONDITION	4428	3782

SAMPLE

*Fuel for start, taxi and take-off is normally 21 lbs at an average mom/100 of 16.

Section VI
Wt and Bal/Equip List

BEECHCRAFT Baron B55
TC-371, TC-502 thru TC-1607

WEIGHT AND BALANCE LOADING FORM

BARON _____ **DATE** _____

SERIAL NO. _____ **REG NO.** **NXXX** _____

ITEM	WEIGHT	MOM/100
1. BASIC EMPTY CONDITION		
2. FRONT SEAT OCCUPANTS		
3. 3rd and 4th SEAT OCCUPANTS		
4. 5th and 6th SEAT OCCUPANTS		
5. NOSE BAGGAGE		
6. REAR BAGGAGE		
7. AFT BAGGAGE		
8. CARGO		
9. SUB TOTAL ZERO FUEL CONDITION		
10. FUEL - MAIN (GAL) FUEL - AUX (GAL)		
11. SUB TOTAL RAMP CONDITION		
12. *LESS FUEL FOR START, TAXI, AND TAKE-OFF		
13. SUB TOTAL TAKE-OFF CONDITION		
14. LESS FUEL - MAIN (GAL)		
15. SUB TOTAL		
16. LESS FUEL - AUX (GAL)		
17. SUB TOTAL		
18. LESS FUEL - MAIN (GAL)		
19. LANDING CONDITION		

*Fuel for start, taxi and take-off is normally 21 lbs at an average mom/100 of 16.

USEFUL LOAD WEIGHTS AND MOMENTS
 (TC-371, TC-502 thru TC-1298)
 OCCUPANTS

	Front Seats		3rd and 4th Seats		5th and 6th Seats
	Fwd Position	Aft Position	Fwd Position	Aft Position	
WEIGHT	ARM 85	ARM 89	ARM 121	ARM 136	ARM 154
	MOM/100				
120	102	107	145	163	185
130	110	116	157	177	200
140	119	125	169	190	216
150	128	134	182	204	231
160	136	142	194	218	246
170	144	151	206	231	262
180	153	160	218	245	277
190	162	169	230	258	293
200	170	178	242	272	308
NOTE: OCCUPANT POSITIONS SHOWN ARE FOR THE SEATS ADJUSTED THE MAXIMUM RANGE. INTERMEDIATE POSITIONS WILL REQUIRE INTERPOLATION OF THE MOMENT/100 VALUES.					

USEFUL LOAD WEIGHTS AND MOMENTS
(TC-1299 thru TC-1607)
OCCUPANTS

	Front Seats		3rd and 4th Seats		5th and 6th Seats
	Fwd Position	Aft Position	Fwd Position	Aft Position	
WEIGHT	ARM 85	ARM 89	ARM 121	ARM 136	ARM 152
	MOM/100				
120	102	107	145	163	182
130	110	116	157	177	198
140	119	125	169	190	213
150	128	134	182	204	228
160	136	142	194	218	243
170	144	151	206	231	258
180	153	160	218	245	274
190	162	169	230	258	289
200	170	178	242	272	304

NOTE: OCCUPANT POSITIONS SHOWN ARE FOR THE SEATS ADJUSTED TO THE MAXIMUM RANGE. INTERMEDIATE POSITIONS WILL REQUIRE INTERPOLATION OF THE MOMENT/100 VALUES.

BAGGAGE

Weight	NOSE	REAR	AFT
	COMPT	FS 131 TO 170	FS 170 TO 190
	ARM 31	ARM 150	ARM 180
	Mom/100	Mom/100	Mom/100
10	3	15	18
20	6	30	36
30	9	45	54
40	12	60	72
50	16	75	90
60	19	90	108
70	22	105	126
80	25	120	144
90	28	135	162
100	31	150	180
110	34	165	198
120	37	180	216
130	40	195	
140	43	210	
150	47	225	
160	50	240	
170	53	255	
180	56	270	
190	59	285	
200	62	300	
220	68	330	
240	74	360	
260	81	390	
270	84	405	
280	87	420	
300	93	450	
320		480	
340		510	
360		540	
380		570	
400		600	

**CARGO
FWD OF SPAR
(CENTER SEATS REMOVED)
ARM 108**

Weight	<u>Moment</u> 100	Weight	<u>Moment</u> 100
10	11	110	119
20	22	120	130
30	32	130	140
40	43	140	151
50	54	150	162
60	65	160	173
70	76	170	184
80	86	180	194
90	97	190	205
100	108	200	216

CARGO
AFT OF SPAR
(CENTER & AFT SEATS REMOVED)
ARM 145

Weight	<u>Moment</u> 100	Weight	<u>Moment</u> 100
10	15	210	305
20	29	220	319
30	44	230	334
40	58	240	348
50	73	250	363
60	87	260	377
70	102	270	392
80	116	280	406
90	131	290	421
100	145	300	435
110	160	310	450
120	174	320	464
130	189	330	479
140	203	340	493
150	218	350	508
160	232	360	522
170	247	370	537
180	261	380	551
190	276	390	566
200	290	400	580

USABLE FUEL

		MAIN WING TANKS ARM 75	AUX WING TANKS ARM 93
Gallons	Weight	Mom/100	
5	30	23	28
10	60	45	56
15	90	68	84
20	120	90	112
25	150	113	140
30	180	135	167
35	210	158	195
40	240	180	223
44	264	198	
45	270	203	251
50	300	225	279
55	330	248	307
60	360	270	335
62	372		346
65	390	293	
70	420	315	
74	444	333	

***OIL**

Quarts	Weight	<u>Moment</u> 100
24	45	19

*Included in Basic Empty Weight

SECTION VII

SYSTEMS DESCRIPTION

TABLE OF CONTENTS

<i>SUBJECT</i>	<i>PAGE</i>
Airframe	7-5
Flight Controls	7-5
Control Surfaces	7-5
Control Column	7-5
Rudder Pedals	7-6
Trim Controls	7-6
Instrument Panel	7-6
Flight Instruments	7-6
Power Plant Instruments	7-7
Illustration	7-8, 7-9
Ground Control	7-7
Wing Flaps	7-7
Landing Gear System	7-10
Control Switch	7-10
Position Indicators	7-10
Safety Switch	7-10
Warning Horn	7-11
Manual Extension	7-11
Brakes	7-12
Baggage/Cargo Compartments	7-12A
Aft Baggage/Cargo Compartment	7-12A
Nose Baggage/Cargo Compartment	7-12B
Seating	7-12B
Seat Belts and Shoulder Harnesses	7-13

TABLE OF CONTENTS (Continued)

<i>SUBJECT</i>	<i>PAGE</i>
Doors, Windows, and Exits	7-13
Forward Cabin Door	7-13
Openable Cabin Windows	7-14
Emergency Exits	7-15
Control Locks	7-16
Power Plants	7-17
Power Plant Controls	7-17
Propeller, Throttle and Mixture	7-17
Induction Air	7-17
Lubrication System	7-18
Cowl Flaps	7-18
Propellers	7-18
Fuel System	7-19
Schematic	7-20
Fuel Pressure Indicator	7-21
Fuel Crossfeed	7-22
Fuel Boost Pumps	7-22
Fuel Required for Flight	7-23
Electrical System	7-23
Schematic	7-24
Battery	7-25
Generators	7-25
Alternators	7-25
Starters	7-26
External Power	7-26
Lighting Systems	7-27
Interior Lighting	7-27
Exterior Lighting	7-27
Heating and Ventilation System	7-28
Cabin Heating	7-28
Heater Operation	7-28
Heat Regulation	7-29
Heater Blower	7-30
Cabin Ventilation	7-30

TABLE OF CONTENTS (Continued)

<i>SUBJECT</i>	<i>PAGE</i>
Exhaust Vents	7-31
Individual Fresh Air Outlets	7-31
Environmental Schematics	7-32, 7-33
Oxygen System	7-34
Pitot and Static System	7-34
Pitot System	7-35
Normal Static System	7-35
Alternate Static System	7-35
Vacuum System	7-36
Stall Warning	7-36
Ice Protection Systems	7-37
Surface Deice System	7-37
Propeller and Windshield Anti-ice System (Fluid Flow)	7-38
Electrothermal Propeller Deice	7-39
Pitot Heat	7-39
Stall Warning Anti-ice	7-39
Engine Break-in Information	7-40

INTENTIONALLY LEFT BLANK

AIRFRAME

The BEECHCRAFT BARON B-55 is a four to six place all-metal, low-wing, twin-engine airplane with retractable tri-cycle landing gear, and a conventional horizontal and vertical stabilizer.

FLIGHT CONTROLS

CONTROL SURFACES

Control surfaces are bearing supported and operated through push-pull rods and conventional cable systems terminating in bellcranks.

CONTROL COLUMN

The throw-over type control column for elevator and aileron control can be placed in front of either front seat. Pull the T-handle latch at the back of the control arm and position the control wheel as desired. Check for full freedom of movement after repositioning the control.

NOTE
(TC-1534 thru TC-1607)

If a reduced power throttle position exists when throwing over the control column, it will be necessary to momentarily move the throttle levers forward for passage of the control column.

The optional dual control column is required for flight instruction.

RUDDER PEDALS

To adjust the rudder pedals, press the spring-loaded lever on the side of each pedal arm and move the pedal to its forward or aft position. The adjustment lever can also be used to place the right set of rudder pedals against the floor, (when the copilot brakes are not installed) when not in use.

TRIM CONTROLS

All trim tabs are adjustable from the control console. A position indicator is provided for each. The left aileron tab incorporates servo action in addition to its trimming purpose. Elevator trim is controlled by a hand wheel located to the left of the throttles. An elevator tab indicator dial is located above and to the left of the trim control hand wheel.

INSTRUMENT PANEL

FLIGHT INSTRUMENTS

The flight instruments are located on a floating panel directly in front of the pilot's seat. Standard flight instrumentation includes attitude and directional gyros, air-speed, altimeter, vertical speed, turn coordinator, and a clock. A magnetic compass is mounted above the instrument panel. The outside air temperature indicator is located either above the instrument panel or on the left side panel. Located on the right side of the instrument panel is the standard vacuum gage for the instrument air system.

POWER PLANT INSTRUMENTS

Most of the engine instruments are located in the upper center of the instrument panel. The standard indicators for each engine are as follows: tachometers, manifold pressure, fuel pressure, fuel quantity, and loadmeters. Other indicators such as the exhaust gas temperature system, the propeller deice ammeter (or propeller alcohol quantity and deice pressure) are usually installed on the right side of the instrument panel. Two multi-purpose instruments, one for each engine, indicate cylinder head temperature, oil pressure, and oil temperature.

GROUND CONTROL

Spring-loaded linkage from the nose gear to the adjustable rudder pedals allows for nose wheel steering. Smooth turning is accomplished by allowing the airplane to roll while depressing the appropriate rudder pedal. The minimum wing tip turning radius, using partial braking action and differential power, is 29 feet 6 inches.

WING FLAPS

The wing flaps are controlled by a three position switch on the left side of the control console. The switch must be pulled out of a detent before operating. The flap position lights, immediately above the control switch, show green for the up position and red for the full down (28°) landing position. Intermediate flap positions of 10° and 20°, as marked on the leading edge of the left flap, may be attained by returning the switch to the OFF position when the desired flap setting mark lines up with the wing trailing edge. A dial-type wing flap position indicator marked UP, 10°, 20°, and DN replaced the lights on serials TC-1011 and after.

Section VII
Systems Description

BEECHCRAFT Baron B55
TC-371, TC-502 thru TC-1607

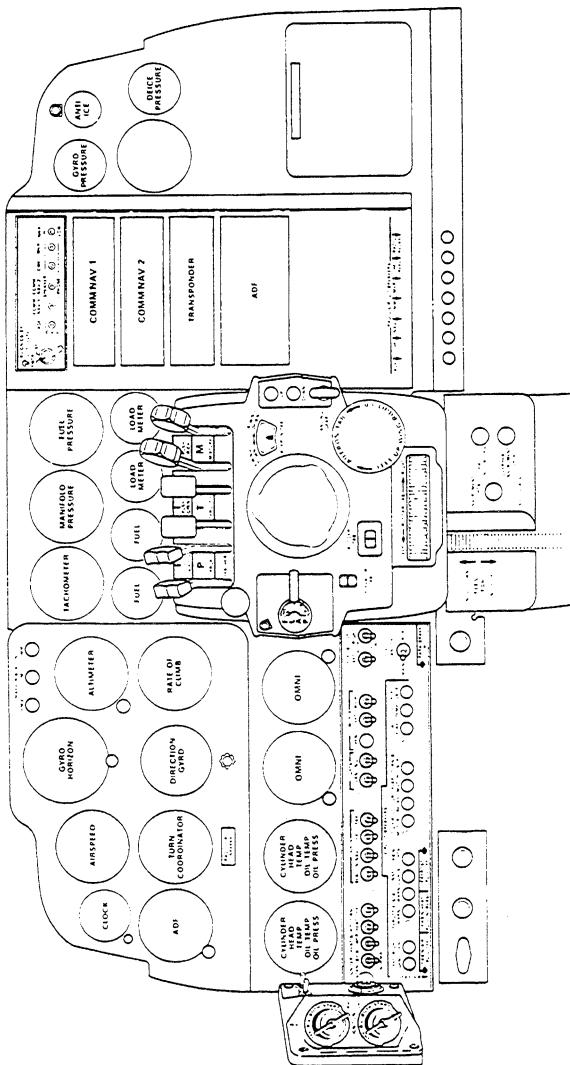

LANDING GEAR SYSTEM

CAUTION

Never taxi with a flat strut.

The landing gear is operated through adjustable linkage connected to an actuator assembly mounted beneath the front seats. The actuator assembly is driven by an electric motor. The landing gear may be electrically retracted and extended, and may be extended manually.

CONTROL SWITCH

The landing gear is controlled by a two-position switch on the right side of the control console. The switch handle must be pulled out of the safety detent before it can be moved to the opposite position. Never operate the landing gear electrically with the handcrank engaged.

POSITION INDICATORS

Landing gear position lights are located above the control switch. The lights, red for gear up and green for gear down, illuminate only when the gear has reached the fully retracted or extended position. In addition, a mechanical pointer at the base of the console shows the position of the nose gear during transit and in the full up or full down position.

SAFETY SWITCH

To prevent inadvertent retraction of the landing gear on the ground, a main strut safety switch opens the control circuit when the strut is compressed.

CAUTION

Never rely on the safety switch to keep the gear down during taxi or on take-off, landing roll, or in a static position. Always make certain that the landing gear switch is in the down position during these operations.

WARNING HORN

If either or both throttles are retarded below an engine setting sufficient to sustain two engine flight with the landing gear retracted, a warning horn will sound intermittently. During one engine operation, the horn can be silenced by advancing the throttle of the inoperative engine until the throttle warning horn switch opens the circuit.

MANUAL EXTENSION

The landing gear can be manually extended, but not retracted, by operating the handcrank on the rear of the pilot's seat. The landing gear handle must be in the down position and the landing gear MOTOR circuit breaker must be pulled before manually extending the gear. When the electrical system is operative, the landing gear may be checked for full down with the gear position lights, provided the landing gear RELAY circuit breaker is engaged. After the landing gear is down, disengage the handcrank. For electrical retraction of the landing gear after a practice manual extension use procedures outlined in the EMERGENCY PROCEDURES section.

If the landing gear was extended for emergency reasons, do not move any landing gear controls or reset any switches or circuit breakers until the aircraft is on jacks, to prevent a gear retraction on the ground. These procedures are outlined in the EMERGENCY PROCEDURES section.

BRAKES

The brakes on the main landing gear wheels are operated by applying toe pressure to the top of the rudder pedals.

CAUTION

Continuous brake application of either the pilot's or copilot's brake pedals in conjunction with an overriding pumping action from the opposite brake pedals could result in the loss of braking action on the side which continuous pressure is being applied.

The parking brake control is located just left of the elevator tab wheel on the pilot's subpanel. To set the parking brakes, pull the control out and depress the pilot's toe pedals until firm. Push the control in to release the brakes.

NOTE

The parking brake should be left off and wheel chocks installed if the airplane is to be left unattended. Changes in ambient temperature can cause the brakes to release or to exert excessive pressures.

The brakes hydraulic fluid reservoir is accessible through the nose baggage door. Fluid level is checked with the dipstick attached to the reservoir cap. The brakes require no adjustments, since the pistons move outward to compensate for lining wear.

BAGGAGE/CARGO COMPARTMENTS

AFT BAGGAGE/CARGO COMPARTMENT

The aft baggage/cargo compartment is accessible through the baggage door on the right side of the fuselage. This area extends aft of the pilot's seats to the rear bulkhead. Because of structural limitations, this area is divided into three sections, each having a different weight limitation. Loading within the baggage/cargo compartment must be in accordance with the data in the **WEIGHT AND BALANCE** section. All cargo must be secured with the approved cargo retention systems.

WARNING

Do not carry hazardous material anywhere in the airplane.

Do not carry passengers in the baggage or cargo area unless secured in a seat.

NOSE BAGGAGE/CARGO COMPARTMENT

The forward baggage/cargo compartment is easily accessible through a large door on the right side of the nose. The door, hinged at the top, swings upward, clear of the loading area. Loading within this area must be within the limitations according to the **WEIGHT AND BALANCE** section. The nose baggage/cargo compartment incorporates the full width of the fuselage as usable space. This compartment also affords accessibility to the oxygen cylinder and to some of the airplane's avionics. Straps are provided and should be used to secure any baggage or cargo loaded into the nose baggage/cargo compartment.

SEATING

To adjust any of the four standard seats forward or aft, pull up on the release bar below the seat and slide the seat to the desired position. The seat backs of all standard seats can be placed in any of four positions by operating a release lever on the inboard side of each seat. An option is available that provides for the seat backs on all seats (except the pilot's) to be placed in any position from vertical to fully reclined. Outboard armrests for all standard seats are built into the cabin sidewalls. A center armrest for the front seats can be elevated or positioned flush with the seat cushions. The inboard armrests for the two standard rear seats can be folded into a stowed position. The optional fifth and sixth seats can be folded up to provide additional floor space, or folded down to provide access to the extended baggage/cargo compartment.

SEAT BELTS AND SHOULDER HARNESSSES

The optional shoulder harness installation is available for the pilot seats only. The belt is in the "Y" configuration with the single strap being contained in an inertia reel attached to the overhead canopy structure of the cockpit. The two straps are worn with one strap over each shoulder and fastened by metal loops into the seat belt buckle. The harness should be used with the seats in the upright position. The spring loading at the inertia reel keeps the harness snug but will allow normal movement required during flight operations. The inertia reel is designed with a locking device that will secure the harness in the event of sudden forward movement or an impact action.

DOORS, WINDOWS AND EXITS

FORWARD CABIN DOOR

The airplane has a conventional cabin door on the forward right side of the fuselage and when closed, the outside cabin door handle is spring loaded to fit into a recess in the door to create a flat aerodynamically clean surface. The door may be locked with a key. To open the door from the outside, lift the handle from its recess and pull until the door opens.

To close the cabin door from the inside, observe that the door handle is in the unlocked position. In this position, the latch handle is free to move approximately one inch in either direction before engagement of the locking mechanism. Then grasp the door and firmly pull the door closed. Rotate the door handle fully counterclockwise into the locked position. When the door is properly locked, the door latch handle is free to move approximately one inch in either direction.

NOTE

When checking the door latch handle, do not move it far enough to engage the door latch release mechanism.

Press firmly outward at the top rear corner of the door. If any movement of the door is detected, completely open the door and close again following the above instructions.

To open the door from the inside, depress the lock button and rotate the handle clockwise.

OPENABLE CABIN WINDOWS

To open window; release latch front of bar, pull bar at the bottom of the window out and upward. Window will open approximately two inches.

Close window by pulling inward and down on the bar at the bottom of the window. Resistance will be felt as the bar moves downward. Continue moving bar downward to its lowest position. Check that bar is locked by the latch.

NOTE

Windows are to be closed before takeoff and during flight. While closing window, ascertain that the emergency release pin (which allows the window to open fully for emergency exit) is securely in place.

EMERGENCY EXITS

To open the emergency exit provided by the openable middle window on each side of the cabin:

1. Lift the latch.
2. Pull out the emergency release pin and push the window out.

The above procedure is described on a placard installed below the left and right middle windows.

CONTROL LOCKS

(TC-371, 502 thru 1436)

1. Insert the spring end of the rudder control locking pin into the hole at the top of the pilot's left rudder pedal.
2. Neutralize the pedals and insert the opposite end of the locking pin into the right pedal by compressing the spring.
3. Place the elevator and aileron controls in an approximately neutral position.
4. Insert the elevator-aileron control locking pin into the hole in the control column hanger and the hole in the underside of the control column tube.
5. Close the throttles and place the throttle lock over the throttle control knobs.

To lessen the possibility of taxi or takeoff with the control lock installed, remove the locking components in the following order: rudder, throttle and elevator-aileron.

(TC-1437 and after)

The control column pin assembly is placarded with the installation instructions. Install the assembly with the instructions facing the instrument panel. Placard reading **CONTROLS LOCKED, REMOVE BEFORE FLIGHT** will be facing pilot if properly installed.

1. Close throttles, install pin between levers, through collar lock and control column. (Rotate control wheel approximately 12° to the right.)
2. Route cable and rudder lock around right side of control column, position pedals in aft position and install lock in rudder pedals.

POWER PLANTS

The BEECHCRAFT BARON B-55 is powered by two Continental IO-470-L six-cylinder, horizontally opposed, fuel injected engines rated at 260 hp at 2625 rpm.

POWER PLANT CONTROLS

PROPELLER, THROTTLE, AND MIXTURE

The control levers are grouped along the upper face of the control console. Their knobs are shaped so they can be identified by touch. A single controllable friction knob below and to the left of the control levers prevents creeping.

INDUCTION AIR

Induction air is available from filtered ram air or alternate air. Filtered ram air enters from above the engine inside the nacelle area. Should the filter become obstructed, a spring-loaded door on the side of the plenum will open automatically and the induction system will operate on alternate air taken from the nacelle area.

LUBRICATION SYSTEM

The engine oil system for each engine is the full pressure, wet sump type and has a 12-quart capacity. Oil operating temperatures are controlled by an automatic thermostat bypass control. The bypass control will limit oil flow through the oil cooler when operating temperatures are below normal and will permit the oil to bypass the cooler if it should become blocked.

The oil system may be checked through access doors in the engine cowling. A calibrated dip stick adjacent to the filler cap indicates the oil level. Due to the canted position of the engines, the dip sticks are calibrated for either right or left engines and are not interchangeable.

The oil grades listed in the Approved Engine Oils in the SERVICING section are general recommendations only, and will vary with individual circumstances. The determining factor for choosing the correct grade of oil is the average ambient temperature.

COWL FLAPS

The cowl flap for each engine is controlled by a separate switch located on the pilot's subpanel to the left of the control console. The cowl flap is closed when the switch is in the up position and open when the switch is down. An amber annunciator light adjacent to the cowl flap switches, illuminates when either switch is in the open position.

PROPELLERS

The engines are equipped with either two or three blade, full feathering, constant speed, propellers. Springs aided

by counterweights move the blades to high pitch. Engine oil under governor-boosted pressure moves the blades to low pitch.

The propellers should be cycled occasionally during cold weather operation. This will help maintain warm oil in the propeller hubs so that the oil will not congeal.

FUEL SYSTEM

The standard fuel tank installation consists of a 22-gallon main tank in each wing leading edge and a 31-gallon auxiliary tank in each wing panel outboard of the nacelle, for a total of 106 gallons of usable fuel with all tanks full. The optional fuel tank installation consists of a 37-gallon main tank in each wing leading edge and a 31-gallon auxiliary tank in each wing panel outboard of the nacelle, for a total of 136 gallons of usable fuel with all tanks full.

A vapor return line from each injector pump returns excess fuel to the tank from which it is being drawn, during either normal or emergency cross-feed operation. Each tank is filled at its own filler neck through an opening in the upper wing surface covered by a flush type filler cap. The fuel system is drained at eight locations, as shown in the accompanying fuel system schematic.

Fuel quantity is measured by float type transmitter units which convey signals to two indicators on the instrument panel. They indicate the amount of fuel in either the main tanks or the auxiliary tanks for their respective wings. A two-position selector switch on the pilot's subpanel, to the left of the control console, determines the tanks, main or auxiliary, to which the indicators are connected.

Section VII
Systems Description

BEECHCRAFT Baron B55
TC-371, TC-502 thru TC-1607

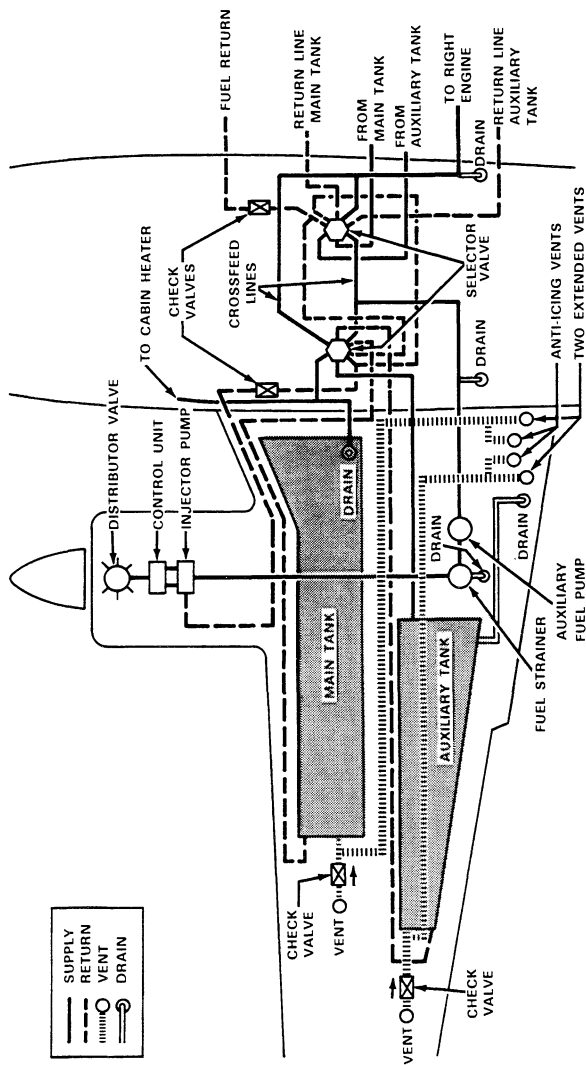

FUEL SYSTEM SCHEMATIC

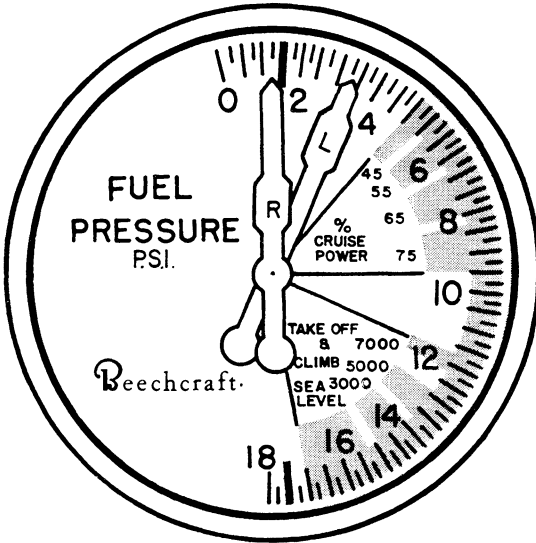

FUEL PRESSURE INDICATOR

The fuel pressure indicator registers metered fuel pressure at the fuel injection manifold valve. It does not indicate either engine-driven fuel pump pressure or fuel boost pump pressure. Red radials are placed at the minimum and maximum allowable operating fuel pressures. The green sectors indicate normal operating range. For fuel flow conversions see PERFORMANCE section.

In the cruise power range the green sectors cover the fuel pressure required from 45% to 75% power. The lower edge of each sector is the normal-lean setting and the upper edge is the best power setting for that particular power range.

Section VII

BEEHCRAFT Baron B55

Systems Description

TC-371, TC-502 thru TC-1607

The takeoff and climb range is covered by green sectors for full power at various altitudes. The full power markings represent the maximum performance mixtures for the altitudes shown, permitting leaning of the mixture for maximum power and performance during high altitude takeoffs and full power climbs.

FUEL CROSSFEED

The separate, identical fuel supplies for each engine are interconnected by crossfeed lines. During normal operation each engine uses its own fuel pumps to draw fuel from its respective fuel tank arrangement. However, on emergency crossfeed operations the entire fuel supply of any or all tanks can be consumed by either engine.

A mechanical interlock prevents both fuel selector valves being placed on cross-feed at the same time, as this would cut off the fuel supply for both engines.

The fuel crossfeed system is provided for use during emergency conditions in level flight only. The system is not to be used to transfer fuel from one tank to another or to balance fuel during flight. The procedure for using the cross-feed system is described in the EMERGENCY PROCEDURES section.

FUEL BOOST PUMPS

An individual two-speed electric fuel boost pump is provided for each engine. HIGH pressure, OFF, or LOW pressure is selected with each fuel boost pump switch on the pilot's subpanel. High pressure is used for stabilizing the fuel pressure before start and provides near maximum engine performance should the engine-driven pump fail. In high ambient temperatures, low pressure should be used

for ground operation, take-off, and climb. The location of the fuel boost pumps in the system permits fuel to be drawn from any tank within the system by the pump for the operating engine. The high pressure position should not be selected while the engine is operating except in the event of engine driven pump failure since the high pressure mode supplies a greater pressure than can be accepted by the injector system for a reduced power condition.

FUEL REQUIRED FOR FLIGHT

Flight planning and fuel loading are facilitated by the use of fuel quantity indicators that have been coordinated with the usable fuel supply. It is the pilot's responsibility to ascertain that the fuel quantity indicators are functioning and maintaining a reasonable degree of accuracy, and be certain of ample fuel for a flight. A minimum of 13 gallons of fuel is required in each main tank before takeoff. An inaccurate indicator could give an erroneous indication of fuel quantity. If the pilot is not sure that at least 13 gallons are in each main tank, add necessary fuel so that the amount of fuel will not be less than 13 gallons per main tank at takeoff. Plan for an ample margin of fuel for any flight.

ELECTRICAL SYSTEM

In general, the airplane's circuitry is the single-wire, ground return type. The battery, magneto/start, and generator or alternator switches are located on the left side panel. The panel to the left of the control console contains most of the electrical system switches and circuit breakers. Each is placarded as to its function. Avionics circuit breakers are located on the right subpanel.

Section VII
Systems Description

BEECHCRAFT Baron B55
TC-371, TC-502 thru TC-1607

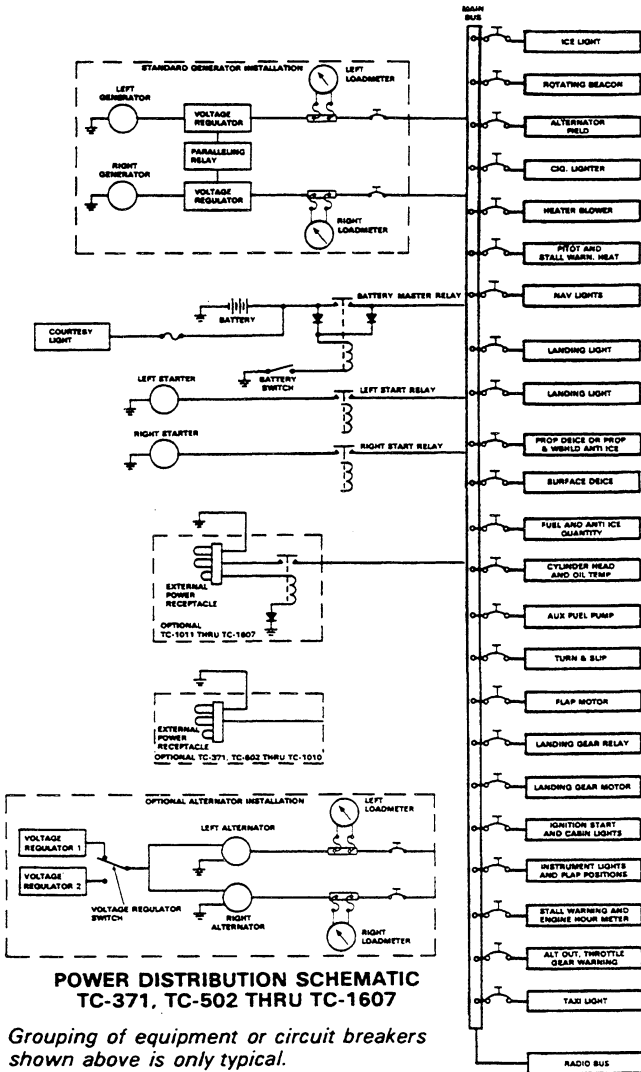

POWER DISTRIBUTION SCHEMATIC
TC-371, TC-502 THRU TC-1607

Grouping of equipment or circuit breakers shown above is only typical. See airplane circuit breaker placards.

BATTERY

One 17 ampere-hour, 24-volt lead acid battery is standard. Two 25 ampere-hour, 12-volt lead acid batteries, connected in series are offered as options. The battery installation is located beneath the floor of the nose baggage compartment. Battery servicing procedures are described in the SERVICING section. The battery can be turned off in flight and the alternator/generators will remain on the line.

GENERATORS

Two 25-ampere, 24-volt generators are standard equipment. The generators are belt-driven from the engine accessory section.

The electrical output of each generator is automatically controlled by an individual voltage regulator and the system paralleling relay. Individual generator output is indicated by two loadmeters on the instrument panel. The power distribution system is protected by circuit breakers.

ALTERNATORS

Two 50-ampere, 24-volt, belt-driven alternators are controlled by two transistorized voltage regulators. Only one regulator is operable in the system at any one time. The remaining regulator is used as an alternate or standby unit. When switched into the circuit, either regulator will adjust alternator output to the required electrical load, including battery recharging. Selection of the regulators is provided by a two-position selector switch below the pilot's subpanel. The power distribution system is protected by circuit breakers.

Individual alternator output is indicated by two loadmeters on the instrument panel. The loadmeters give a percentage reading of the load on the system.

Section VII

BEEHCRAFT Baron B55

Systems Description

TC-371, TC-502 thru TC-1607

On serials TC-371, TC-502 thru TC-1042, a press-to-test overvoltage warning light on the instrument panel illuminates whenever the alternators are disconnected from the aircraft bus by an overvoltage relay located forward of the instrument panel.

On serials TC-1043 thru TC-1607, two annunciator ALT OUT lights are on the instrument panel. They will illuminate whenever their respective alternator is disconnected from the bus by low voltage or an overvoltage condition or with the switch in the OFF position. Any time a failure is detected the appropriate alternator should be turned off.

STARTERS

The starters are relay-controlled and are actuated by rotary type, momentary-on switches incorporated in the magneto/start switches located on the pilot's side panel. To energize the starter circuit, hold the magneto/start switch in the START position. After starting, release the switch to the BOTH position.

EXTERNAL POWER

The external power receptacle is located in the outboard side of the left nacelle and accepts a standard AN type plug. The power unit should be capable of delivering at least 300 amperes for starting. Before connecting an external power unit, turn the electrical systems and avionics off to avoid damage due to electrical surges. If the unit does not have a standard AN type plug, check the polarity (negative ground) and connect the positive lead from the external power unit to the center post of the airplane's receptacle. The negative lead connects to the other large post. If the airplane is equipped with a reverse polarity relay (TC-1011 and after), positive power must also be connected to the small guide pin. If polarity is reversed on TC-1011 and after, a diode in the coil circuit will prevent contactor operation. When external power is connected, the battery switch should be turned on.

LIGHTING SYSTEM

INTERIOR LIGHTING

The cabin dome light is operated by an OFF-ON switch forward of the light. Individual reading lights above the standard third and fourth or the optional fifth and sixth seats are operated by switches between the air and light outlets. Three rheostat switches are located on the control console. One switch adjusts the intensity of the instrument flood lights located under the glareshield. Lighting for the instruments is controlled by the second switch. The third switch regulates the lighting for the electrical panel, avionics panel, and the fuel selector panel, plus the trim tab and mechanical landing gear position indicators.

On B55 Baron models TC-1403 and after, the magnetic compass light, outside air temperature indicator light and map light are operated by a switch on the pilot's control wheel.

EXTERIOR LIGHTING

The switches for the navigation lights, landing lights, rotating beacons, nose taxi light, and wing ice light(s) are grouped along the top of the pilot's subpanel. The landing lights in the leading edge of each wing tip are operated by separate switches. For longer battery and lamp service life, use the landing lights only when necessary. Avoid prolonged operation, during ground maneuvering, which could cause overheating. At night, reflections from rotating anti-collision lights on clouds, dense haze, or dust can produce optical illusions and vertigo. The use of these lights may not be advisable under instrument or limited VFR conditions.

HEATING AND VENTILATION SYSTEM

CABIN HEATING

A combustion heater in the nose supplies heated air to the cabin. Outlets are located forward of the pilot and copilot seats, at the rear of the copilot's seat, and at the rear of the right passenger seat. The fifth outlet provides heated air for windshield defrosting.

In flight, fresh ram air enters an intake on each side of the nose cone, passes through the heater, and is distributed to the cabin outlets. For ground operation, a blower maintains airflow through the system.

If a malfunction resulting in dangerously high temperatures should occur, a thermostat will ground a fuse in the heater power circuit. This renders the heater system, except the blower, inoperative. **MAKE CERTAIN ANY MALFUNCTION CAUSING THE OVERHEAT FUSE TO BLOW IS CORRECTED BEFORE ATTEMPTING TO OPERATE THE HEATER AGAIN.**

HEATER OPERATION

1. For B55 Baron models TC-371, TC-502 thru TC-954, a two-position switch, placarded **HEAT AND BLOWER**, is located on the pilot's subpanel. To place the heating system in operation, move the switch to the **ON** position.

For B55 Baron models TC-955 thru TC-1607, a three-position switch, placarded **BLOWER, OFF, and HEATER**, is located on the pilot's subpanel. To place the heating system in operation, move the switch to the **HEATER** position.

2. The CABIN AIR control, which regulates the amount of intake air, is below the left side of the pilot's subpanel. Push the CABIN AIR control full forward.
3. Pull out the CABIN HEAT control to the right of the CABIN AIR control to increase the temperature of the heated air. Push the CABIN HEAT control in to decrease temperature.
4. For windshield defrosting, push in the DEFROST control located to the right of the CABIN HEAT control.
5. To direct heated air onto the pilot's feet, pull out the PILOT AIR control to the right of the DEFROST control. (Only TC-955 and after)
6. The COPILOT AIR control, identical to the PILOT AIR control, is located below the right side of the instrument panel. (Only TC-955 and after)

HEAT REGULATION

For maximum heat, the CABIN AIR control can be pulled partially out to reduce the volume of incoming cold air and permit the heater to raise the temperature of the admitted air. However, if the CABIN AIR control is pulled out more than halfway, the heater will not operate.

The volume of air available for the pilot outlet and the copilot outlet can be divided between the two outlets as desired by adjusting each control individually.

More heated air will be available for defrosting by reducing the flow of air from the pilot outlet, copilot outlet, or both.

The PILOT AIR and COPILOT AIR controls can be used to regulate the amount of air distributed to the two rear outlets.

HEATER BLOWER

(TC-371, TC-502 thru TC-954)

When the two-position switch on the pilot's subpanel is placed in the HEATER & BLOWER position, the blower will operate if the landing gear is in the extended position and the CABIN AIR control is more than halfway in. The blower will automatically shut off if the landing gear is retracted or the CABIN AIR control is pulled out more than halfway.

(TC-955 thru TC-1607)

When the three-position switch on the pilot's subpanel is placed in either the HEATER position or the BLOWER position, the blower will operate if the landing gear is in the extended position and the CABIN AIR control is more than halfway in. The blower will automatically shut off if the landing gear is retracted or the CABIN AIR control is pulled out more than halfway.

CABIN VENTILATION

In flight, to provide unheated air for the same cabin outlets used for heating, push the CABIN AIR and CABIN HEAT controls forward.

For ventilation during ground operation:

(TC-371, TC-502 thru TC-954)

Push the CABIN AIR control forward and place the two-position HEAT & BLOWER switch on the pilot's subpanel in the ON position.

(TC-955 thru TC-1607)

Push the CABIN AIR control forward and place the three position switch on the pilot's subpanel in the BLOWER position.

EXHAUST VENTS

An adjustable cabin air exhaust vent is located aft of the radio speaker in the overhead panel. This overhead vent can be closed by a control located in the overhead panel. Fixed exhaust vents are located along the cabin floor under the baggage door. A fixed exhaust vent is located in the back of the hat shelf on TC-1481 and after.

INDIVIDUAL FRESH AIR OUTLETS

Individual Overhead Fresh Air Outlets

(TC-502 thru TC-954)

A manually retractable air scoop on top of the cabin conducts outside air to individual fresh-air outlets in the overhead upholstery panel above each seat. The outlets can be manually adjusted to control both the quantity and direction of air flow. The air scoop may be closed by operating a push-pull control located on the overhead panel.

(TC-955 thru TC-1607)

Fresh ram air from the air intake on the left side of the dorsal fairing is ducted to individual outlets above each seat including the optional seats. Each outlet can be positioned to direct the flow of air as desired. The volume of incoming air can be regulated by rotating the outlet. A push-pull control in the overhead panel enables the pilot to adjust the amount of ram air available to all outlets (TC-969 and after).

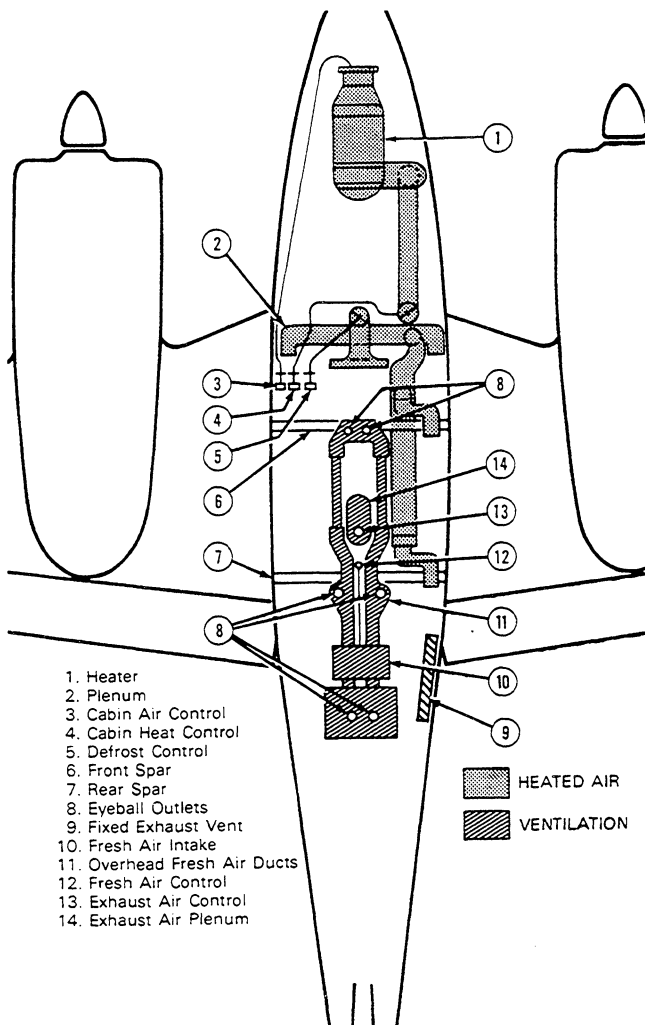

HEATING AND VENTILATION SYSTEM SCHEMATIC
TC-371, TC-502 THRU TC-954

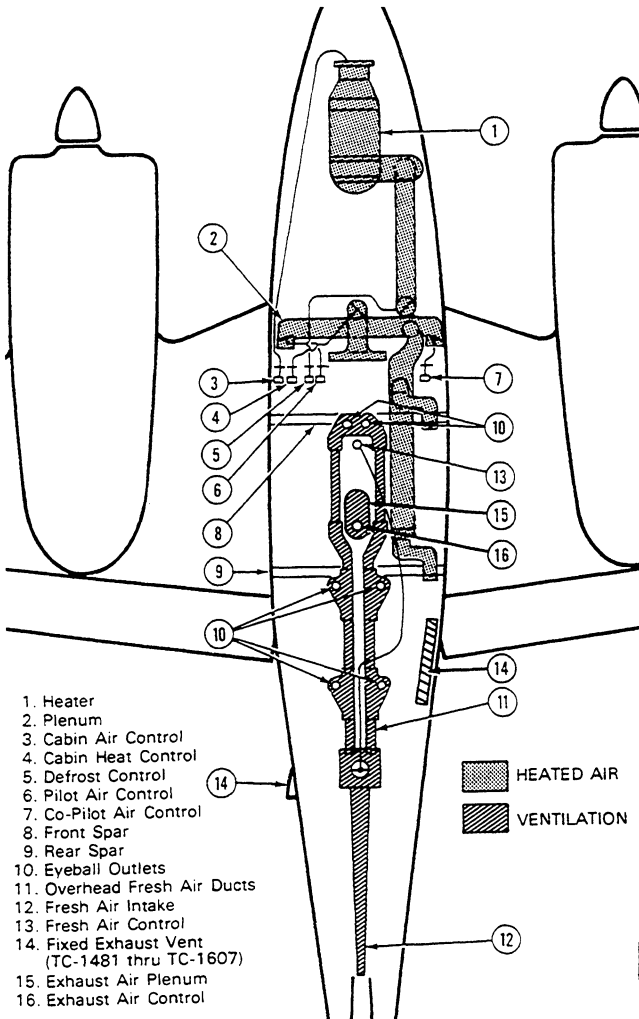

**HEATING AND VENTILATION SYSTEM SCHEMATIC
 TC-955 THRU TC-1607**

PITOT SYSTEM

A standard pitot tube for the pilot's flight instruments is located under the left wing and the optional pitot tube for the copilot's instruments is located under the right wing.

The pitot system needs no drain because of the location of the components.

A pitot heat switch, located on the pilot's left subpanel, supplies heat to the left and right pitot masts.

NORMAL STATIC SYSTEM

Static air is taken from a flush static port located on each side of the aft fuselage. The static air is routed to the rate-of-climb indicator, altimeter and airspeed indicator.

To drain the static air line on serials TC-371 and TC-502 thru TC-954, remove one end of the hose which forms the static air line drain on the left side panel near the aft bulkhead and permit the system to drain. On serials TC-955 and after, the static air line is drained at the emergency static air source or static air drain located on the lower left cabin sidewall by raising the lever to the up position. Return the lever to normal position after the line is completely drained.

ALTERNATE STATIC SYSTEM

The alternate static air source is designed to provide a source of static pressure to the instruments from inside the fuselage should the outside static air ports become blocked. An abnormal reading of the instruments supplied with static air could indicate a restriction in the outside static air ports. A lever on the lower sidewall adjacent to the pilot selects the normal or alternate static air source. To recognize the need and procedures for the use of alternate static air, refer to EMERGENCY PROCEDURES. Airspeed Calibrations and Altimeter Corrections charts are in the PERFORMANCE section.

VACUUM SYSTEM

Suction for the vacuum-operated gyroscopic flight instruments is supplied by two engine-driven vacuum pumps, interconnected to form a single system. If either pump fails, check valves automatically close and the remaining pump continues to operate all gyro instruments. A suction gage on the instrument panel indicates the amount of suction in the vacuum system in inches of mercury. On later serial airplanes two red buttons on the gage serve as source failure indicators, each for its respective side of the system.

STALL WARNING

A stall warning horn on the cabin forward bulkhead sounds a warning signal while there is time for the pilot to correct the attitude. The horn is triggered by a sensing vane on the leading edge of the left wing and is effective in all flight attitudes and at all weights and airspeeds. Irregular and intermittent at first, the warning signal will become steady as the airplane approaches a complete stall.

In icing conditions, stalling airspeeds should be expected to increase due to the distortion of the wing airfoil when ice has accumulated on the airplane. For the same reason, stall warning devices tend to lose their accuracy. The sensing vane is installed on a plate that can be electrically heated, preventing ice from forming on the vane of the transducer. A switch on the pilot's subpanel, placarded PITOT HEAT, supplies power to the heated pitot mast and to the heating plate at the stall warning transducer. However, any accumulation of ice in the proximity of the stall warning vane reduces the probability of accuracy in the stall warning system whether or not the vane itself is clear of ice. For this reason, it is advisable to maintain an extra margin of airspeed above the stall speed.

ICE PROTECTION SYSTEMS

SURFACE DEICE SYSTEM

Deice boots bonded to the leading edges of the wings and the tail surfaces are operated by engine-driven pump pressure. Compressed air, after passing through the pressure regulator, goes to the distributor valve. When the deice system is not in operation, the distributor valve applies vacuum to the boots to deflate and hold the boots flat against the surface. Then, when the deice system is operated, the distributor valve changes from vacuum to pressure and the boots inflate. After the cycle is completed, the valve returns to vacuum hold down.

A three-position, spring loaded switch, with a center OFF position, a MAN (manual) down position, and an up AUTO (automatic) position, controls the system. When the switch is in the AUTO position, the deice boots inflate for a period of five to six seconds, then deflate automatically and return to the vacuum hold down position. The switch must be tripped for each complete cycle. In the MAN position the deice boots inflate as long as the switch is held in this position. When the switch is released, the boots deflate and go to the vacuum hold down condition.

Deice boots are designed to remove ice after it has accumulated, rather than prevent its formation. If the rate of ice accumulation is slow, best results are obtained by leaving the deice system off until 1/2 to 1 inch of ice accumulates. Bridging can occur if boots are actuated too early or too frequently.

The wing ice light(s), used to check for ice accumulation during night operation, illuminates the wing leading edge. The light switch is on the pilot's subpanel.

Section VII

BEEHCRAFT Baron B55

Systems Description

TC-371, TC-502 thru TC-1607

PROPELLER AND WINDSHIELD ANTI-ICE SYSTEM (FLUID FLOW)

The system is designed to prevent the formation of ice. Always place the system in operation before encountering icing conditions.

Ice is prevented from forming on the propeller blades by wetting the blade anti-ice boots with anti-icing fluid. The anti-ice pump delivers a constant flow of fluid from the supply tank to the blade boots. The pump is controlled by an ON-OFF switch located on the pilot's subpanel.

Windshield anti-ice (when installed) receives anti-ice fluid from the same source as the propeller anti-ice system. Ice is prevented from forming on the windshield by wetting the windshield surface with anti-ice fluid. This combined system is controlled by a three position switch, MOM ON-OFF-ON, located on the pilot's subpanel. The system will not function unless the propeller anti-ice pump switch is turned ON. For windshield system only, the flow is controlled by an ON-OFF switch. An indicator on the right side of the instrument panel indicates the amount of fluid in the supply tank.

With a full reservoir, system endurance is:

Windshield	approx. 36 min.
Prop Anti-ice Only	approx. 120 min.
Prop & Windshield	approx. 28 min.

ELECTROTHERMAL PROPELLER DEICE (2 and 3 BLADES)

Propeller ice removal is accomplished by the electrically heated deice boots bonded to each propeller blade. The system uses the aircraft electrical power to heat portions of the deice boots in a sequence controlled by a timer. The system is controlled by an ON-OFF switch on the pilot's subpanel. When the system is turned on the ammeter will register 7 to 12 amperes on the 2 blade propeller, or 14 to 18 amperes on the 3 blade propeller. The system can be operated continuously in flight; it will function automatically until the switch is turned off. Propeller imbalance can be relieved by varying rpm. Increase rpm briefly, then return to the desired setting. Repeat if necessary.

CAUTION

Do not operate the system with the engines inoperative.

PITOT HEAT

Heating elements are installed in the pitot mast(s). Both heating elements are controlled by an individual switch located on the pilot's subpanel. The switch is placarded PITOT HEAT, and should remain off during ground operations, except for testing or for short intervals of time to remove ice or snow from the mast(s).

STALL WARNING ANTI-ICE (Optional)

The mounting pad and the stall warning vane are equipped with a heating element that is activated any time the switch placarded PITOT HEAT, is on.

ENGINE BREAK-IN INFORMATION

Use a straight mineral oil as recommended by the engine manufacturer throughout the break-in period. Drain the initial oil at 20 to 30 hours, replace with new mineral oil which is to be used until oil consumption stabilizes, usually a total of about 50 hours.

Drain and replace the engine oil as recommended in **HANDLING, SERVICING AND MAINTENANCE**. If operating conditions are unusually dusty or dirty, more frequent oil changes may be necessary. Oil changes are more critical during the break-in period than at any other time.

Use full throttle at recommended rpm for every take-off and maintain until at least 400 feet AGL, then reduce as necessary for cruise climb or cruise. Maintain the highest power recommended for cruise operations during the break-in period, avoiding altitudes above 8000 feet. Interrupt cruise power every 30 minutes or so by smoothly advancing to take-off power settings for about 30 seconds, then returning to cruise power settings.

Avoid long power-off descents especially during the break-in period. Maintain sufficient power during descent to permit cylinder head temperatures to remain in the green arc.

Minimize ground operation time, especially during warm weather. During the break-in period, avoid engine idling in excess of 15 minutes, especially in high ambient temperatures.

SECTION VIII

HANDLING, SERVICING AND MAINTENANCE

TABLE OF CONTENTS

<i>SUBJECT</i>	<i>PAGE</i>
Introduction	8-5
Publications	8-6
Airplane Inspection Periods	8-6
Preventative Maintenance That May Be	
Accomplished By A Certificated Pilot	8-7
Alterations or Repairs to Airplane	8-7
Ground Handling	8-8
Towing	8-8
Parking	8-9
Tie-Down	8-9
Main Wheel Jacking	8-10
Prolonged Out of Service Care	8-10
Storage	8-10
Flyable Storage - 7 to 30 Days	8-10
Mooring	8-10
Engine Preparation For Storage	8-11
During Flyable Storage	8-11
Fuel Cells	8-12
Flight Control Surfaces	8-12
Grounding	8-12
Pitot Tube(s)	8-12
Windshield and Windows	8-12
Preparation For Service	8-12

TABLE OF CONTENTS (Continued)

<i>SUBJECT</i>	<i>PAGE</i>
External Power	8-13
Recharging Battery Using	
Auxiliary Power	8-14
Checking Electrical Equipment	8-14
Servicing	8-15
Fuel System	8-15
Fuel Cells	8-15
Fuel Drains	8-15
Fuel Strainers	8-16
Oil System	8-16
Battery	8-17
Tires	8-18
Shock Struts	8-18
Shimmy Damper	8-20
Brakes	8-21
Induction Air Filter	8-21
To Remove and Clean the Filter	8-22
Propellers	8-22
Propeller and Windshield Anti-ice	
Tank (Fluid)	8-23
Oxygen System	8-23
Oxygen Cylinder Retesting	8-24
Minor Maintenance	8-24
Rubber Seals	8-24
Heating and Ventilating System	8-25
Alternators	8-25
Magnetos	8-26
Cleaning	8-26A
Exterior Painted Surfaces	8-26A
Windshield and Windows	8-28
Surface Deice Boots	8-28
Engine	8-29
Interior	8-29

TABLE OF CONTENTS (Continued)

<i>SUBJECT</i>	<i>PAGE</i>
Lubrication Points	8-30 - 8-35
Recommended Servicing Schedule	8-36 - 8-41
Consumable Materials	8-42
Approved Engine Oils	8-44
Bulb Replacement Guide	8-46
Overhaul or Replacement Schedule	8-47
Special Conditions Cautionary Notice	8-47
Landing Gear	8-48
Power Plant	8-48
Fuel System	8-49
Instruments	8-50
Electrical System	8-50
Utility Systems	8-51
Flaps and Flight Controls	8-52
Miscellaneous	8-52

INTENTIONALLY LEFT BLANK

INTRODUCTION

The purpose of this section is to outline the requirements for maintaining the airplane in a condition equal to that of its original manufacture. This information sets the time frequency intervals at which the airplane should be taken to a BEECHCRAFT Aero or Aviation Center for periodic servicing or preventive maintenance.

The Federal Aviation Regulations place the responsibility for the maintenance of this airplane on the owner and operator of the airplane who must ensure that all maintenance is done by qualified mechanics in conformity with all airworthiness requirements established for this airplane.

All limits, procedures, safety practices, time limits, servicing and maintenance requirements contained in this handbook are considered mandatory.

Authorized BEECHCRAFT Aero or Aviation Centers will have recommended modification, service, and operating procedures issued by both FAA and Beech Aircraft Corporation, designed to get maximum utility and safety from the airplane.

If there is a question concerning the care of the airplane, it is important to include the airplane serial number in any correspondence. The B55 (TC-371, TC-502 thru TC-1035) serial number appears on the model designation placard attached to the underside of the fuselage just forward of the tiedown. The designation placard on B55 (TC-1036 and after) is attached to the right side of the fuselage at the in-board end of the flap.

PUBLICATIONS

The following publications are available through BEEHCRAFT Aero or Aviation Centers.

1. Shop Manual
2. Parts Catalog
3. Service Instructions
4. Various Inspection Forms

NOTE

Neither Service Publications, Reissues, nor Revisions are automatically provided to the holder of this manual. For information on how to obtain "Revision Service" applicable to this manual, consult any BEEHCRAFT Aero or Aviation Center or refer to the latest revision of BEEHCRAFT Service Instructions No. 0250-010.

AIRPLANE INSPECTION PERIODS

1. FAA Required 100 Hour and/or Annual Inspections.
2. BEEHCRAFT Recommended Inspection Guide.
3. Continuing Care Inspection Guide.
4. See "Recommended Servicing Schedule" and Overhaul or Replacement Schedule" for further inspection schedules.

NOTE

Check the wing bolts for proper torque at the first 100 hour inspection and at the first 100 hour inspection after each reinstallation of the wing attach bolts.

**PREVENTATIVE MAINTENANCE THAT MAY
BE ACCOMPLISHED BY A CERTIFICATED PILOT**

1. A certificated pilot may perform limited maintenance. Refer to FAR Part 43 for the items which may be accomplished.

To ensure proper procedures are followed, obtain a BEECHCRAFT Shop Manual for performing preventative maintenance.

2. All other maintenance must be performed by licensed personnel.

NOTE

Pilots operating airplanes of other than U. S. registry should refer to the regulations of the country of certification for information on preventative maintenance that may be performed by pilots.

ALTERATIONS OR REPAIRS TO AIRPLANE

The FAA should be contacted prior to any alterations on the airplane to ensure the airworthiness of the airplane is not violated.

NOTE

Alterations or repairs to the airplane must be accomplished by licensed personnel.

GROUND HANDLING

The three-view drawing in Section 1 shows the minimum hangar clearances for a standard airplane. Allowances must be made for any special radio antennas.

CAUTION

To insure adequate propeller clearance, always observe recommended shock strut servicing procedures and tire inflation pressures.

TOWING

Attach the tow bar to the tow pin on the nose gear lower torque knee. It is recommended to have someone in the airplane to operate the brakes.

CAUTION

Do not exert force on the propellers, control surfaces, or horizontal stabilizer. When towing with a tug, limit turns to prevent damage to the nose gear. Do not attempt to tow airplane backward by the tail tiedown ring. Do not tow when the main gear is obstructed by mud or snow. Also ensure the rudder lock is removed.

Care should be used when removing the tow bar to prevent damage to the lubrication fittings on the landing gear.

PARKING

The parking brake control is located just left of the elevator tab wheel on the pilot's subpanel. To set the parking brakes, pull control out and depress each toe pedal until firm. Push the control in to release the brakes.

NOTE

Excessive pedal pressure may prevent releasing of the parking brake.

The parking brake should be left off and wheel chocks installed if the airplane is to be left unattended. Changes in ambient temperature can cause the brakes to release or to exert excessive pressures.

TIE-DOWN

It is advisable to nose the airplane into the wind. Three tie-down lugs are provided: one on the lower side of each wing and a third at the rear of the fuselage.

1. Install the control locks.
2. Chock the main wheels, fore and aft.
3. Using nylon line or chain of sufficient strength, secure the airplane at the three points provided. **DO NOT OVER TIGHTEN**; if the line at the rear of the fuselage is excessively tight, the nose may rise and produce lift due to the angle of attack of the wings.
4. Release the parking brake.

If high winds are anticipated, a vertical tail post should be installed at the rear tie-down lug, and a tie-down line attached to the nose gear.

MAIN WHEEL JACKING

1. Check the shock strut for proper inflation to prevent damage to the landing gear door by the jack adapter and to facilitate installation of the adapter.
2. Insert the main wheel jack adapter into the main wheel axle.
3. A scissors-type jack is recommended for raising and lowering the wheel.
4. When lowering the wheel, exercise care to prevent compression of the shock strut, which would force the landing gear door against the jack adapter.

NOTE

Persons should not be in or on the airplane while it is on a main wheel jack.

PROLONGED OUT OF SERVICE CARE**STORAGE**

Storage procedures are intended to protect the airplane from deterioration while it is not in use. The primary objectives of these measures are to prevent corrosion and damage from exposure to the elements.

Flyable Storage (7-30 days) has been considered here. For more extended storage periods, consult the Beech Airplane Shop Manual and Continental Service Bulletin M 74-9 or later issue.

FLYABLE STORAGE - 7 TO 30 DAYS***MOORING***

If airplane cannot be placed in a hangar, tie down securely at the three points provided. Do not use hemp or manila

rope. It is recommended a tail support be used to compress the nose strut and reduce the angle of attack of the wings. Attach a line to the nose gear.

ENGINE PREPARATION FOR STORAGE

Engines in airplanes that are flown only occasionally tend to exhibit cylinder wall corrosion much more than engines that are flown frequently.

Run engines at least five minutes at 1200 to 1500 rpm with oil and cylinder head temperatures in the normal operating range.

Check for correct oil level and add oil if necessary to bring level to full mark.

DURING FLYABLE STORAGE

Each seven days during flyable storage, the propellers shall be rotated by hand. After rotating each engine six revolutions, stop the propellers 60° or 120° from the position they were in.

WARNING

Before rotation of propeller blades, ascertain magneto/start switches are OFF, throttles are in the CLOSED position, and mixture controls are in the IDLE CUT-OFF position. Always stand in the clear while turning propellers.

If at the end of 30 days, airplane will not be removed from storage, the engines shall be started and run. The preferred method will be to fly the airplane for 30 minutes, and up to, but not exceeding normal oil and cylinder temperatures.

EXTERNAL POWER

When using external power, it is very important that the following precautions be observed:

1. The airplane has a negative ground system. Exercise care to avoid reversed polarity. Be sure to connect the positive lead of the auxiliary power unit to the positive terminal of the airplane's external power receptacle and the negative lead to the negative terminal of the external power receptacle. A positive voltage must also be applied to the small guide pin.

NOTE

A negative ground external power source is required. If the polarity is reversed on airplanes prior to TC-1011 the avionics may be damaged. On TC-1011 and after, the reverse polarity relay will not close thus preventing current flow to the airplane.

2. To prevent arcing, make certain no power is being supplied when the connection is made.
3. Make certain that the battery switch is ON, all avionics and electrical switches OFF, and a battery is in the system before connecting an external power unit. This protects the voltage regulators and associated electrical equipment from voltage transients (power fluctuations).

**RECHARGING THE BATTERY
(USING AUXILIARY POWER)**

1. Battery switch - ON
2. Generators/Alternators, Electrical and Avionics Equipment - OFF
3. Connect auxiliary power unit
4. Set the output of the external power unit at 27.0 to 28.5 volts
5. Auxiliary power unit - ON

If the battery relay will not close, the battery must be removed from the aircraft for recharging. Check the battery relay control circuit for a malfunction.

CHECKING ELECTRICAL EQUIPMENT

Connect an auxiliary power unit as outlined in Starting Procedures. Ensure that the current is stabilized prior to making any electrical equipment or avionics check.

NOTE

If the external power unit has poor voltage regulation or produces voltage transients, the aircraft electrical equipment connected to the unit may be damaged.

SERVICING

FUEL SYSTEM

FUEL TANKS

See Consumable Materials for recommended fuel grades.

All fuel tanks in each wing are serviced through two fuel fillers. Refer to the LIMITATIONS section for the usable fuel for both standard and optional fuel tank arrangements.

Ground the airplane with a static line before refueling and secure the filler caps immediately after filling. Before letting the airplane stand for several days, it is a good practice to fill the wing fuel system to ensure that the cell inner liners do not dry out and crack, allowing fuel to diffuse through the cell walls. Also, less moisture condensation will occur when fuel tanks are full. If the tanks are to be drained before storage, a coating of light engine oil should be sprayed or flushed onto the inner liners of the cells as a preservative.

FUEL DRAINS

Open each of the snap-type fuel drains to purge any water from the system. The standard fuel system has a total of eight drains. Two sump drains extend through the bottom of each wing. There is one drain in each wing wheel well for the fuel strainer, and two drains extending through the fuselage for the system low spot.

FUEL STRAINERS

To preclude the possibility of contaminated fuel, always cap any disconnected fuel lines or fittings. The fuel strainer in each wheel well should be inspected and cleaned with solvent at regular intervals. The frequency of inspection and cleaning will depend upon service conditions, fuel handling cleanliness, and local sand and dust conditions. At each 100-hour inspection the strainer plug should be removed from the fuel injection control valve and the fuel injection control valve screen washed in fresh cleaning solvent. After the strainer plug has been re-installed and safetied, the installation should be checked for leakage. A leading edge sump strainer, accessible through an access door on the bottom of the wing, should be cleaned periodically.

OIL SYSTEM

The engines are equipped with a wet sump, pressure type oil system. Each engine sump has a capacity of 12 quarts. The oil system may be checked through access doors in the engine cowling. A calibrated dipstick adjacent to the filler cap indicates the oil level. Due to the canted position of the engines, the dipsticks are calibrated for either right or left engines and are not interchangeable.

The oil should be changed every 25 hours under normal operating conditions. The oil drain is accessible through the cowl flap opening. The engines should be warmed to operating temperature to assure complete draining of the oil.

Moisture that may have condensed and settled in the oil sump should be drained occasionally by opening the oil drain plug and allowing a small amount of oil to escape. This is particularly important in winter, when the moisture will collect rapidly and may freeze.

The engine manufacturer recommends the use of ashless dispersant oils. In order to promote faster ring seating and oil control, a straight mineral oil should be used for the first change period or until oil consumption stabilizes. Dispersant oils must meet Teledyne Continental Motors Corporation Specification MHS-24B.

Aviation Grade Oil	Average Ambient Air Temperature
SAE 50	Above 5°C (40°F)
SAE 30	Below 5°C (40°F)

BATTERY

LEAD ACID

The battery is accessible by opening the forward baggage compartment door and removing the battery box cover from the floor of the compartment. Check the electrolyte level after each 25 hours of operation and add distilled water as necessary. Avoid filling over the baffles and never fill over the split ring or more than one-quarter inch over the separator tops.

Excessive water consumption may be an indication that the voltage regulators require resetting. The specific gravity of the electrolyte should be checked periodically and maintained within the limits placarded on the battery.

The battery box is vented overboard to dispose of electrolyte and hydrogen gas fumes discharged during the normal charging operation. To ensure disposal of these fumes the vent hose connections at the battery box should be checked frequently for obstructions.

NICKEL CADMIUM

The two 24-ampere hour, 12-volt, nickel cadmium batteries connected in series are accessible by removing the battery cover located at floor level on the right side of the nose baggage compartment. When service is required for the nickel cadmium battery, it is recommended it be serviced at a qualified Nickel Cadmium Battery Shop.

TIRES

Nose Wheel Tire (5.00 x 5)

Prior to TC-1010	50 psi
TC-1010 and after	65 psi

Main Wheel Tires (6.50 x 8)

Prior to TC-1020	50 psi
TC-1020 and after	65 psi

Maintaining recommended tire inflation will minimize tread wear and aid in preventing tire failure caused from running over sharp stones and ruts. When inflating tires, visually inspect them for cracks, breaks, or evidence of internal damage.

NOTE

Beech Aircraft Corporation cannot recommend the use of recapped tires. Recapped tires have a tendency to swell as a result of the increased temperature generated during takeoff. Increased tire size can jeopardize proper function of the landing gear retract system, with the possibility of damage to the landing gear doors and retract mechanism.

SHOCK STRUTS

CAUTION

DO NOT taxi with a flat shock strut.

The shock struts are filled with compressed air and hydraulic fluid. The same procedure is used for servicing both the main and the nose gear shock struts. To service a strut, proceed as follows:

1. Jack the airplane, remove the air valve cap, depress the valve core, and allow the strut to fully deflate.

WARNING

Do not unscrew the valve body assembly until all air pressure has been released or it may be blown off with considerable force, causing injury to personnel or damage to equipment.

2. Carefully remove the valve body assembly.
3. Compress the strut and fill through the air valve assembly hole with hydraulic fluid (approximately one pint) until the fluid overflows.
4. Cycle the strut from full extension to compressed and refill. Repeat until no more fluid can be added to the strut in the compressed position.

NOTE

Cycling of the shock strut is necessary to expel any trapped air within the strut housing.

5. Install the air valve assembly.
6. With the airplane resting on the ground and the fuel cells full, inflate the nose gear strut until 4-1/2 inches of the piston are exposed and inflate the main gear struts until 3 inches of the piston are exposed. Rock the airplane gently to prevent possible binding of the piston in the barrel while inflating.

NOTE

It is recommended that the nose strut inflation dimension and the tire inflation pressures be carefully adhered to. Properly inflated tires and struts reduce the possibility of ground damage occurring to the propellers. Exercise caution when taxiing over rough surfaces.

7. Remove all foreign material from the exposed piston with a soft cloth moistened with hydraulic fluid.

CAUTION

If a compressed air bottle containing air under extremely high pressure is used, exercise care to avoid over-inflating the shock strut.

WARNING

NEVER FILL SHOCK STRUTS WITH OXYGEN.

SHIMMY DAMPER

The shimmy damper has a reservoir of fluid carried in the piston rod. Two coil springs installed in the piston rod keep fluid in the shimmy damper under pressure. As fluid is lost through leakage it is automatically replenished from the reservoir until the reservoir supply is exhausted.

To check the fluid level in the shimmy damper, insert a wire, approximately 1/32 inch in diameter, through the hole in the disc at the aft end of the piston rod until it touches the bottom of the hole in the floating piston. Mark the wire, remove it, and measure the depth of the insertion. When the shimmy damper is full, insertion depth is 2-3/16 inches, when empty, 3-1/16 inches.

NOTE

The measuring wire should be inserted in the hole in the floating piston rather than against the piston face to give a more accurate reading. To determine if the wire is inserted in the hole in the floating piston, insert the wire several times, noting insertion depth each time. When the wire is inserted in the hole, the depth will be about 1/4 inch greater than when it rests against the piston face.

When the shimmy damper is found empty or nearly empty, it should be refilled. See Shop Manual.

BRAKES

The brake hydraulic fluid reservoir is accessible through the nose baggage compartment. A dipstick is attached to the reservoir cap. Refer to Consumable Materials for hydraulic fluid specification.

The brakes require no adjustments since the pistons move to compensate for lining wear. See Shop Manual for specific brake wear limits information.

INDUCTION AIR FILTERS

The filters should be inspected for foreign matter at least once during each 50-hour operating period. In adverse climatic conditions, or if the airplane is stored, preflight inspection is recommended.

TO REMOVE AND CLEAN THE FILTER:

1. Remove the access plate in the top of the engine cowling.
2. Remove the second access plate on top of the air box and slide out the filter.
3. Remove the filter and clean as noted by the manufacturer's instructions.
4. Reinstall the filter and the plates.

PROPELLERS

The daily preflight inspection should include a careful examination of the propeller blades for nicks and scratches.

Propeller operation, servicing, and maintenance instructions are contained in the propeller owner's manual furnished with the airplane.

WARNING

When servicing a propeller, always make certain that the ignition switch is off and that the engine has cooled completely. **WHEN MOVING A PROPELLER, STAND IN THE CLEAR; THERE IS ALWAYS SOME DANGER OF A CYLINDER FIRING WHEN A PROPELLER IS MOVED.**

PROPELLER AND WINDSHIELD ANTI-ICE TANK (FLUID)

The tank is located beneath the floor on the left side of the forward baggage compartment. The filler cap is accessible through an access door in the floor of the compartment. Capacity is 3 U.S. gallons of anti-ice fluid (see Consumable Materials). The tank should be drained and flushed twice a year.

OXYGEN SYSTEM

WARNING

Keep hands, tools, clothing, and oxygen equipment clean and free from grease and oil. **KEEP FIRE AWAY FROM OXYGEN.**

1. Read the pressure indicator on the oxygen console. (The shutoff valve on the oxygen cylinder must be open.) If the oxygen cylinder is equipped with a gage, system pressure may be checked at the cylinder.

CAUTION

Always open the cylinder shutoff valve slowly to prevent damage to the system.

2. Make certain that the oxygen control valve (located in the sidewall oxygen console) is closed (PUSH IN).
3. Close the cylinder shutoff valve, remove the cap from the filler valve, and attach the recharging outlet. Open valve on supply bottle.
4. Open the cylinder shutoff valve and fill the cylinder to 1800 ± 50 psi (add 3.5 psi per degree above 70°F; subtract 3.5 psi per degree below 70°F).

Section VIII

Handling, Serv - Maint

BEEHCRAFT Baron B55

TC-371, TC-502 thru TC-1607

5. Close the cylinder shutoff valve, close valve on the supply bottle, remove the recharging outlet, and replace the filler valve cap.
6. Reopen the cylinder shutoff valve to prepare system for use.

OXYGEN CYLINDER RETESTING

Oxygen cylinders used in the airplane are of two types. Light weight cylinders, stamped "3HT" on the plate on the side, must be hydrostatically tested every three years and the test date stamped on the cylinder. This bottle has a service life of 4,380 pressurizations or twenty-four years, whichever occurs first, and then must be discarded. Regular weight cylinders, stamped "3A", or "3AA", must be hydrostatically tested every five years and stamped with the retest date. Service life on these cylinders is not limited.

MINOR MAINTENANCE

RUBBER SEALS

To prevent sticking of the rubber seals around the windows, doors, and engine cowling, the seals should be coated with Oakite 6 compound. The compound is noninjurious to paint and can be removed by employing normal cleaning methods.

HEATING AND VENTILATING SYSTEM

The heater fuel pump filter in the nose wheel well should be removed and cleaned after each 100 hours of airplane operation. Remove the filter by turning the base of the pump counterclockwise. Wash the filter in clean unleaded gasoline and dry with compressed air.

The iris valve at the heater blower inlet should be lubricated occasionally with molybdenum disulfide (see Consumable Materials). The valve should never be lubricated with oil or any liquid lubricant which would collect dust.

Do not replace the overheat fuse until a thorough inspection of the system has determined the cause and the malfunction has been corrected.

ALTERNATORS

Since the alternator and voltage regulator are designed for use on only one polarity system, the following precautionary measures must be observed when working on the charging circuit, or serious damage to the electrical equipment will result:

1. When installing a battery, make certain that the ground polarity of the battery and the ground polarity of the alternator are the same.
2. When connecting a booster battery, be sure to connect the negative battery terminals together and the positive battery terminals together.

3. When using a battery charger, connect the positive lead of the charger to the positive battery terminal and the negative lead of the charger to the negative battery terminal.

4. Do not operate an alternator on open circuit. Be sure all circuit connections are secure.

5. Do not short across or ground any of the terminals on the alternator or voltage regulator.

6. Do not attempt to polarize an alternator.

MAGNETOS

Ordinarily, the magnetos will require only occasional adjustment, lubrication, and breaker point replacement. This work should be done by an authorized BEECHCRAFT Aero or Aviation Center.

WARNING

To be safe, treat the magnetos as hot whenever a switch lead is disconnected at any point; they do not have an internal automatic grounding device. Otherwise, all spark plug leads should be disconnected or the cable outlet plate on the rear of the magneto should be removed.

CLEANING

EXTERIOR PAINTED SURFACES

WARNING

Do not expose control surface trim tab hinge lines and their pushrod systems to the direct stream or spray of high-pressure, soap-and-water washing equipment. Fluid dispensed at high pressure could remove the protective lubricant, allowing moisture from heavy or prolonged rain to collect at hinge lines, and then to freeze at low temperatures. After high-pressure or hand washing, and at each periodic inspection, lubricate trim tab hinge lines and trim tab pushrod end fittings (Brayco 300 per Federal Specification VV-L-800 preferred). See Consumable Materials.

CAUTION

When cleaning landing gear areas with solvent, especially if high-pressure equipment is used, exercise care to avoid washing away grease from landing gear components. After washing the landing gear areas with solvent, lubricate all lubrication points, or premature wear may result.

Do not apply wax, polish, rubbing compound, or abrasive cleaner to any uncured painted surface. Use of such items can permanently damage the surface finish. Also, waxes and polishes seal the paint from the air and prevent curing.

Alkyd enamel (sometimes called "automotive enamel"), acrylic enamel, lacquer, and dope

CAUTION

finishes require a curing period of approximately 90 days; Acrylic urethane, polyester urethane, and epoxy finishes undergo a curing process for a period of 30 days after application. Wash uncured painted surfaces with a mild non-detergent soap (MILD detergents can be used on urethane finishes) and cold or luke-warm water only. Use soft cloths, keeping them free of dirt and grime. Any rubbing of the surface should be done gently and held to a minimum to avoid damaging the paint film. Rinse thoroughly with clear water. Stubborn oil or soot deposits may be removed with automotive tar removers.

Prior to cleaning, cover the wheels, making certain the brake discs are covered. Attach the pitot cover securely, and plug or mask off all other openings. Be particularly careful to mask off all static air buttons before washing or waxing. Use special care to avoid removing lubricant from lubricated areas.

When using high-pressure washing equipment, keep the spray or stream clear of wheel bearings, propeller hub bearings, etc., and openings such as pitot tubes, static air buttons, and battery and avionics equipment cooling ducts, which should be securely covered or masked off. Avoid directing high-pressure sprays toward the fuselage, wings, and empennage from the rear, where moisture and chemicals might more easily enter the structure, causing corrosion damage to structural members and moving parts.

Hand washing may be accomplished by flushing away loose dirt with clean water, then washing with a mild soap and water, using soft cleaning cloths or a chamois. Avoid harsh, abrasive, or alkaline soaps or detergents which could cause corrosion or scratches. Thorough clear-water rinsing pre-

vents buildup of cleaning agent residue, which can dull the paint's appearance. To remove oily residue or exhaust soot, use a cloth dampened with an automotive tar remover. Wax or polish the affected area, if necessary.

There is some variation in the procedures required for proper care of the several types of exterior paint. During the curing period, do not make prolonged flights in heavy rain or sleet, and avoid all operating conditions which might cause abrasion or premature finish deterioration. Alkyd enamel, lacquer, and dope finishes must be polished and waxed periodically to maintain luster, and to assure protection from the weather. Acrylic enamel should be waxed, and may be polished, if desired. Acrylic urethane may be waxed for protection from the elements, but should not be polished unless polishing or buffing is required to restore a damaged area. Waxing of polyester urethane finishes, although not required, is permitted; however, never use abrasive cleaner type waxes, polishes, or rubbing compounds, as these products cause eventual deterioration of the characteristic urethane gloss. Epoxy finishes should be waxed on a regular basis, and may be polished and buffed to restore appearance should "chalking" occur. For waxing, select a high quality automotive or aircraft waxing product. Do not use a wax containing silicones, as silicone polishes are difficult to remove from surfaces. A buildup of wax on any exterior paint finish will yellow with age; therefore, wax should be removed periodically. Generally, aliphatic naphtha (see Consumable Materials) is adequate and safe for this purpose.

NOTE

Before returning the airplane to service, remove all maskings and coverings, and re-lubricate as necessary.

WINDSHIELD AND WINDOWS

The windshield and plastic windows should be kept clean and waxed at all times. To prevent scratches wash the windows carefully with plenty of soap and water, using the palm of the hand to feel and dislodge dirt and mud. A soft cloth, chamois or sponge may be used, but only to carry water to the surface. Rinse thoroughly, then dry with a clean, moist chamois. Rubbing the surface of the plastic with a dry cloth builds up an electrostatic charge which attracts dust particles in the air.

Remove oil and grease with a cloth moistened with isopropyl alcohol. Never use gasoline, benzine, alcohol, acetone, carbon tetrachloride, fire extinguisher fluid, anti-ice fluid, lacquer thinner or glass cleaner. These materials will soften plastic and may cause it to craze.

After thoroughly cleaning, the surface should be waxed with a good grade of commercial wax. The wax will fill in the minor scratches and help prevent further scratching. Apply a thin, even coat of wax and bring it to a high polish by rubbing lightly with a clean, dry, soft flannel cloth. Do not use a power buffer; the heat generated by the buffing pad may soften the plastic.

SURFACE DEICE BOOTS

The surfaces of the deice boots should be checked for indication of engine oil after servicing and at the end of each flight. Any oil spots that are found should be removed with a non-detergent soap and water solution. Care should be exercised during cleaning. Avoid scrubbing the surface of the boots as this will tend to remove the special graphite surfacing. The deice boots are made of soft, flexible stock which may be damaged if gasoline hoses are dragged over the surface of the boots or if ladders and platforms are rested against them.

ENGINE

Clean the engine with neutral solvent. Spray or brush the fluid over the engine, then wash off with water and allow to dry. Solutions which may attack rubber or plastics should not be used.

INTERIOR

To remove dust and loose dirt from the upholstery, headliner, and carpet, clean the interior regularly with a vacuum cleaner.

Blot up any spilled liquid promptly with cleansing tissue or rags. Do not pat the spot; press the blotting material firmly and hold it for several seconds. Continue blotting until no more liquid is taken up. Scrape off sticky materials with a dull knife; then spot-clean the area.

Oily spots may be cleaned with household spot removers, used sparingly. Before using any solvent, read the instructions on the container and test it on an obscure place on the fabric to be cleaned. Never saturate the fabric with a volatile solvent; it may damage the padding and backing materials.

Soiled upholstery and carpet may be cleaned with foam-type detergent used according to the manufacturer's instructions. To minimize wetting the fabric, keep the foam as dry as possible and remove it with a vacuum cleaner.

The plastic trim, instrument panel, and control knobs need only be wiped with a damp cloth. Oil and grease on the control wheel and control knobs can be removed with a cloth moistened with isopropyl alcohol. Volatile solvent, such as mentioned in the article on care of plastic windows should never be used since they often craze the plastic.

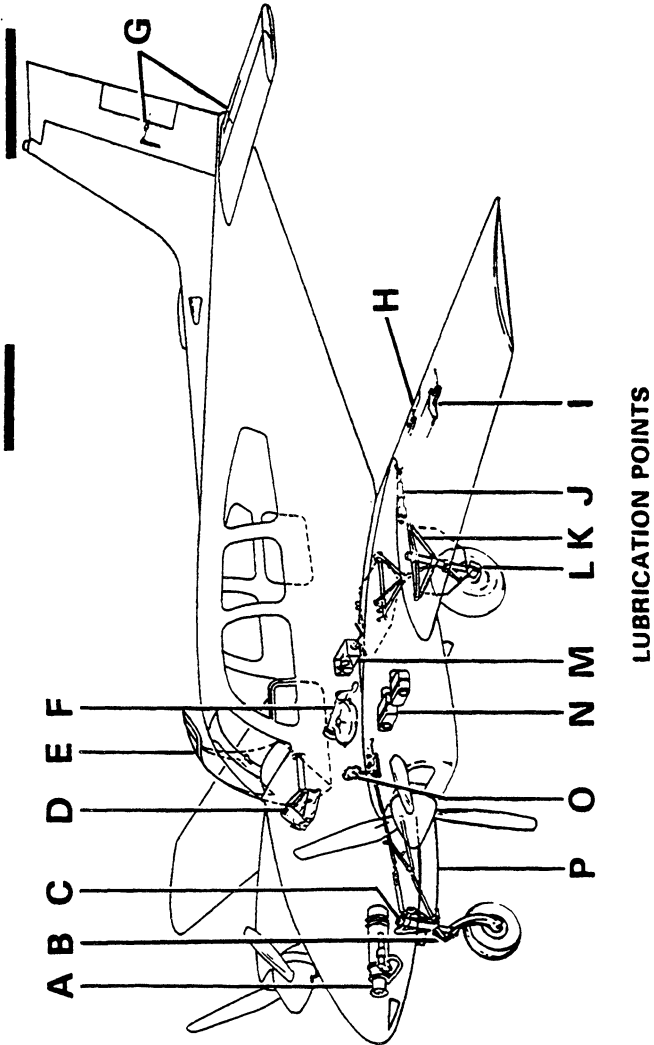

A

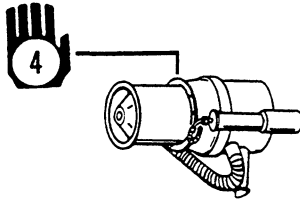

HEATER IRIS VALVE

B

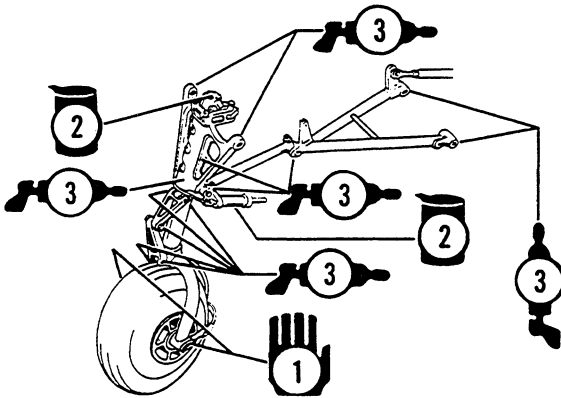

NOSE GEAR RETRACT

C

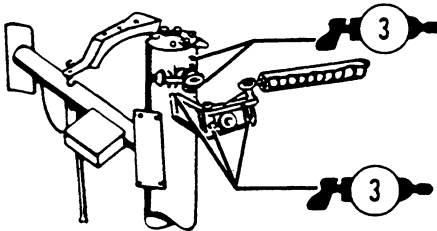

NOSE WHEEL STEERING

D

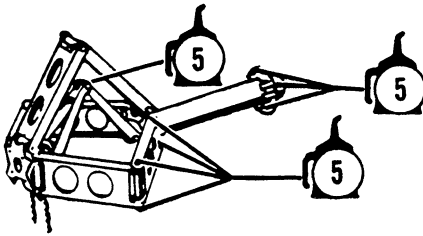

CONTROL COLUMN LINKAGE

E

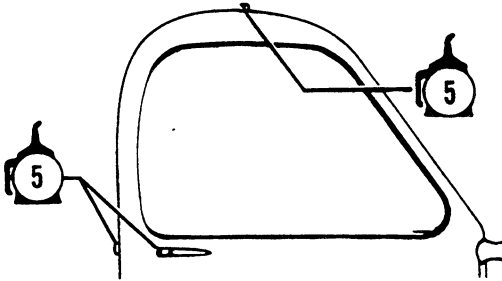

CABIN DOOR

F

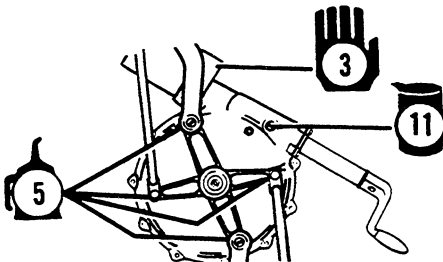

LANDING GEAR GEAR BOX

G

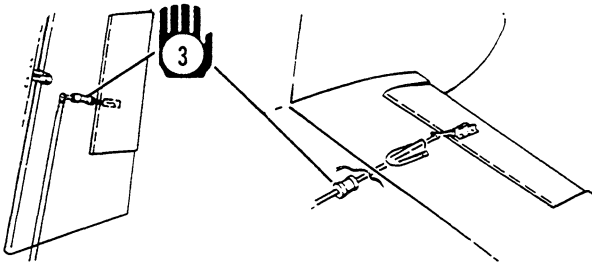

RUDDER TRIM

ELEVATOR TAB

H

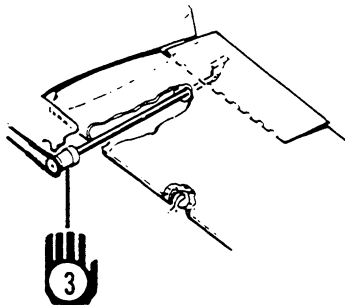

AILERON TAB

I

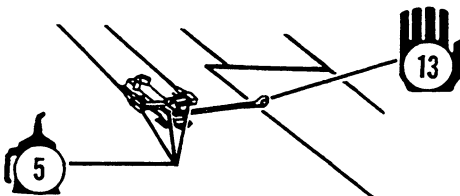

AILERON BELL CRANKS

J

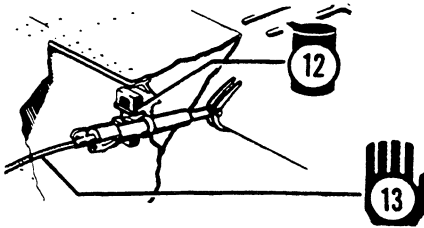

FLAP ACTUATOR

K

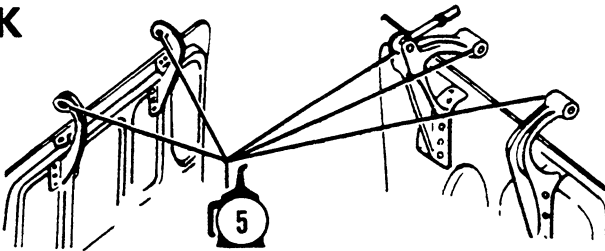

LANDING GEAR DOOR HINGES

L

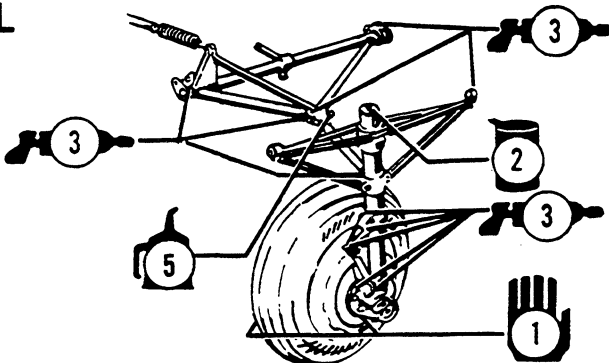

LANDING GEAR RETRACT

M

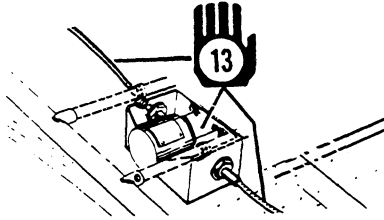

FLAP MOTOR GEAR BOX

O

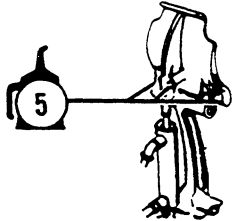

RUDDER PEDALS

P

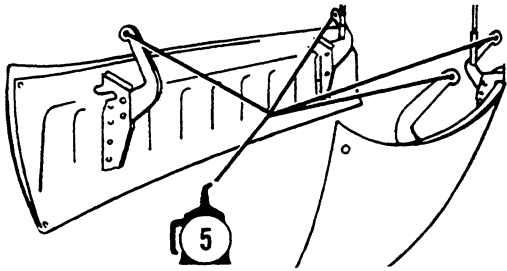

LANDING GEAR DOOR HINGES



HAND OR PACK



ZERK FITTING



FLUID CONTAINER



SQUIRT CAN

NOTE: Letters are keyed to the Service Schedule; Numbers refer to items in the Consumable Materials Chart.

RECOMMENDED SERVICING SCHEDULE

INTERVAL	ITEM	LOCATION (Letters refer to Lubrication Points Diagram)	(Number refers to item on Consumable Materials)
Pre-flight	Check engine oil level Drain main fuel cell drains Drain fuel strainer drains Drain fuel system low spot drains Drain heater fuel filter (prior to TC-1406) Drain box section cell Service fuel cells	Access door on upper cowling Lower wing surface (leading edge) Wing surface fwd of main wheel well Lower fuselage, inboard of wing root Nose wheel well Aft bottom wing surface Top of wings	6 - - - - - 7
25 Hrs.	Check battery electrolyte Change engine oil Clean oil screen	Fwd baggage compartment under floor Access plate on lower nacelle Access door on right side of cowl	See Shop Manual 6 9

50 Hrs.	Clean induction air filter †Lubricate landing gear uplock rollers	Access plate, induction scoop Main landing gear (L)	5
100 Hrs.	Clean fuel strainers Clean fuel injection control valve screen Clean heater fuel filter (prior to TC-1406) Clean heater fuel pump strainer ††Lubricate landing gear uplock rollers Clean and check spark plugs Check magneto timing Lubricate landing gear door hinges Lubricate nose wheel steering mechanism	In wheel wells Access door on side of nacelle Nose wheel well Nose wheel well Main landing gear (L) Under cowl, both sides engine Engine compartment (N) Landing gear wheel wells (K) (P) Nose wheel well (C)	*9 *9 *9 *9 3 - - 5 3

*Clean with solvent and blow dry with compressed air.

RECOMMENDED SERVICING SCHEDULE

INTERVAL	ITEM	LOCATION (Letters refer to Lubrication Points Diagram)	(Number refers to item on Consumable Materials)
100 Hrs. (Cont.)	Lubricate landing gear retract mechanism Lubricate wheel bearings Lubricate cabin door mechanism Lubricate aileron bell cranks and control rod ends Lubricate control column linkage Lubricate rudder pedals Drain static air lines Central instrument air inlet filter(s). Check and replace as necessary (TC-1014 and after) Clean oil separator	Nose wheel and main gear wheel wells (B) (L) Landing gear (B) (L) Cabin door latch (E) Access panel underside wings (I) Forward of instrument panel (D) Cockpit (O) Left forward or aft cabin sidewall Behind instrument panel On firewall	3, 5 1 5 5, 13 5 5 - Donaldson EBG03-0003

100 Hrs. (Cont.)	Replace gyro filters	Mounted on each gyro instrument	
300 Hrs.	Rod end bearings Service landing gear actuator gear box	Control system and landing gear Under front seats (F)	Oil or grease as required 11
500 Hrs.	Replace central instrument air inlet filter(s) (TC-1014 and after)	Behind instrument panel	Donaldson EBG03-0003
600 Hrs.	Service landing gear motor-reduction gears Lubricate flap motor reduction gears	Under front spar cover (F) Under front spar cover (M)	3 13
900 Hrs.	Lubricate flap flex drives Lubricate flap actuators	Forward of flap underside of wing (J)	13 12
900 Hrs. or 5 years whichever occurs first	Lubricate rudder and elevator trim tab actuators Lubricate aileron trim tab actuators	Empennage (G) Aileron (H)	3 3

RECOMMENDED SERVICING SCHEDULE

INTERVAL	ITEM	LOCATION (Letters refer to Lubrication Points Diagram)	(Number refers to item on Consumable Materials)
As Req.	Service wing fuel system Service propeller/wind- shield anti-ice reservoir Service oxygen cylinder Service brake fluid reservoir Drain moisture from engine oil sump Service main gear struts Service nose gear strut Service shimmy damper Check brake lining wear Lubricate heater iris	At wing fillers Under left floorboard, forward baggage compartment Nose baggage compartment Nose baggage compartment Through cowl flap opening Top of each strut (L) Top of strut (B) Nose landing gear (B) Main landing gear wheels Forward nose compart- ment (A)	7 8 18 2 - 2 2 2 - 4

Note 3	Replace emergency locator transmitter battery	At emergency locator
--------	---	----------------------

NOTES: 1. Anytime the control surfaces are altered, repaired, or repainted, they must be re-balanced per the Shop Manual.

2. Check the wing bolts for proper torque at the first 100-hour inspection and at the first 100-hour inspection after each reinstallation of the wing attach bolts.

3. Rechargeable Batteries: Recharge after one cumulative hour of use or after 50% of the useful charge life.

Non-rechargeable Batteries: Replace after one cumulative hour or as noted on the battery.

† TC-371, TC-502 through TC-1402 which have not been modified per S.I. O448-211; the uplock roller should be lubricated with oil at 50 hours and hand packed with grease at 100 hours.

†† TC-1403 and after, and previous airplanes which have been modified per S.I. O448-211; the uplock roller will require only greasing through the zerk installed in the bolt head, at each 100 hours.

CONSUMABLE MATERIALS

Only the basic number of each Military Specification is included in the Consumable Materials Chart. No attempt has been made to update the basic number with the letter suffix that designates the current issues of the various specifications.

Vendors listed as meeting Federal and Military Specifications are provided as reference only and are not specifically recommended by Beech Aircraft Corporation; consequently, any product conforming to the specification listed may be used. The products listed below have been tested and approved for aviation usage by Beech Aircraft Corporation, by the vendor, or by compliance with the applicable specifications. Other products that are locally procurable which conform to the requirements of the applicable Military Specification may be used even though not specifically included herein.

It is the responsibility of the operator/user to determine the current revision of the applicable Military Specification prior to usage of that item. This determination may be made by contacting the vendor of a specific item.

CONSUMABLE MATERIALS

ITEM	MATERIAL	SPECIFICATION
1.	Lubricating Grease High Temperature	Aeroshell No. 5 or MIL-G-81322
<i>CAUTION</i>		
Do not mix Aeroshell No. 5 with MIL-G-81322. Thoroughly clean grease from bearings and bearing area before changing grease.		
2.	Hydraulic Fluid	MIL-H-5606
*3.	Lubricating Grease, General Purpose, Wide Temperature	MIL-G-81322
4.	Molybdenum Disulfide	MIL-M-7866
5.	Lubricating Oil	SAE No. 20 or SAE 10W-30
**6.	Engine Oil	SAE 30 (Below 40°F) SAE 50 (Above 40°F) Approved Multi- viscosity Oils
***7.	Engine Fuel	Grade 100LL (Blue) preferred, 100 (Green)
8.	Anti-Ice Fluid	MIL-F-5566
9.	Solvent	Federal Specification, PD680

Section VIII
Handling, Serv - Maint

BEECHCRAFT Baron B55
TC-371, TC-502 thru TC-1607

ITEM	MATERIAL	SPECIFICATION
10.	Lubricant	Scintilla 10-86527
11.	Lubricant	Mobil Compound GG or Mobil 636
12.	Lubricating Oil, Gear	MIL-L-10324, or MIL-L-2105C, Grade 75W
13.	Grease, Aircraft and Instrument	MIL-G-23827
†14.	Lubricant, Rubber Seal	Oakite 6 Compound
15.	Naptha, Aliphatic	Federal Specification, TT-N-95
††16.	Tape, Antiseize Tetrafluorethylene	MIL-T-27730
17.	Leak Test Compound, Oxygen Systems	MIL-L-25567
18.	Oxygen, Aviator's Breathing	MIL-O-27210
19.	Lubricating Oil, General Purpose, Preservative (Water- Displacing, Low Temperature)	●Brayco 300 per Federal Specifi- cation VV-L-800 (Preferred)

Alternates for Brayco 300:

Lubricant	●●CRC 3-36
	●●●LPS No. 1
	●●●●WD-40

- * In extremely cold climates use MIL-G-23827 grease in place of MIL-G-81322. (These greases harmful to paint.)
- ** Ashless dispersant oil (latest revision of Teledyne Continental Motors Corp. Spec. MHS-24) recommended; straight mineral oils recommended during break-in period. See servicing data.
- *** If 100LL grade fuel (blue) is not available, use 100 (green) as minimum grade. See Engine Manufacturer's Service Letter for recommended maintenance and servicing techniques.
- † Product of Oakite Products, Inc., 50 Valley Road, Berkley Heights, N.J. 07922.
- †† For sealing tapered pipe threads on high pressure oxygen lines.
 - Product of Bray Oil Co.,
1925 North Marianna
Los Angeles, Calif. 90032
 - Product of CRC Chemicals, Inc.,
Warminster, Pa. 18974
 - Product of LPS Research Laboratories, Inc.,
2050 Cotner Ave,
W. Los Angeles, Calif. 90025
 - Product of WD-40 Company,
1061 Cudahy Place,
San Diego, Calif. 92110

Section VIII**Handling, Serv - Maint****BEECHCRAFT Baron B55****TC-371, TC-502 thru TC-1607****APPROVED ENGINE OILS**

COMPANY	BRAND AND WEIGHT
BP Oil Corporation	B/P Aero Oil D65/80
Castrol Limited (Australia)	Grade 40, Castrolaero AD, Type III Grade 50, Castrolaero AD, Type II
Continental Oil Co.	Conoco Aero S (SAE 10W30)
Delta Petroleum Co.	Delta Avoil - Grades 30, 40 - 50
Gulf Oil Corporation	Gulfpride Aviation AD
Humble Oil & Refining Company	Esso Aviation Oil Enco Aviation Oil
Pennzoil Company	Pennzoil Aircraft Engine Oil, Heavy Duty Dispersant, Grades 30, 40, 50
Phillips Petroleum Co.	Phillips 66 Aviation Oil Type A (Replaced HD Aviation Oil)
Quaker State Oil Refining Corp.	Quaker State AD Aviation Engine Oil Grades 20W/30, 40 - 50

**BEECHCRAFT Baron B55
TC-371, TC-502 thru TC-1607**

**Section VIII
Handling, Serv - Maint**

COMPANY	BRAND AND WEIGHT
Shell Oil Company	Aeroshell Oil W (in 4 grades) Grade 120 (Nominal SAE 60) - Military Grade 1120 Grade 100 (Nominal SAE 50) - Military Grade 1100 Grade 80 (Nominal SAE 40) - Military Grade 1080 Grade 65 (Nominal SAE 20 or 30) - Military Grade 1065
Sinclair Refining Co.	Sinclair Avoil 20W-40
Socony-Mobil	Mobil Aero Oil 65 } (Ashless Mobil Aero Oil 80 } Dispersant Mobil Aero Oil 100 } Aviation Mobil Aero Oil 120 } Engine Oil)
Texaco, Inc.	Texaco Aircraft Engine Oil - Premium AD, Grades 65, 80, 100
Union Oil Co. of California	Union Aircraft Engine Oil HD Grades 80 - 100

NOTE

This chart lists all oils which were certified as meeting the requirements of Teledyne Continental Motors Corporation Specification MHS-24B at the time this handbook was published. Any other oil which conforms to this specification may be used.

BULB REPLACEMENT GUIDE

LOCATION	NUMBER
Compass light	303
Cowl flap position light	313
Dome light, cabin	303
Electrical panel light	327
Flap position indicator light	327
Fuel pump placard light	1819
Fuel selector placard light	327
Ice light	A-7796A-24
Instrument light, flood	303
Instrument light, post	327
Landing gear position light	327
Landing gear visual indicator light	356
Landing light	4596
Map light	303
Navigation light, tail	1203
Navigation light, wing	1524
Overvoltage warning light	330
Alternator out light	2390A17
Reading light	1495
Rotating beacon	A-7079B-24 Grimes
Tab position indicator light	1819R
Taxi light (prior to TC-890)	4570
(TC-890 and after)	4626

OVERHAUL OR REPLACEMENT SCHEDULE

The first overhaul or replacement should be performed not later than the required period. The condition of the item at the end of the first period can be used as a criterion for determining subsequent periods applicable to the individual airplane or fleet operation, providing the operator has an approved monitoring system.

The time periods for inspection noted in this handbook are based on average usage and average environmental conditions.

SPECIAL CONDITIONS CAUTIONARY NOTICE

Airplanes operated for Air Taxi or other than normal operation and airplanes operated in humid tropics or cold and damp climates, etc., may need more frequent inspections for wear, corrosion and/or lack of lubrication. In these areas periodic inspections should be performed until the operator can set his own inspection periods based on experience.

NOTE

The required periods do not constitute a guarantee that the item will reach the period without malfunction, as the aforementioned factors cannot be controlled by the manufacturer.

COMPONENT	OVERHAUL OR REPLACE
Oil cooler	On condition (replace when contaminated)
Propeller (Hartzell)	1500 hours or 4 years. Reduce to 1000 hours or 2 years if airplane is stored out in the weather.
Propeller (McCauley)	1500 hours if accumulated in 3 calendar years, otherwise 1200 hours.
Propeller controls	On condition
Propeller governor	At engine overhaul but not to exceed 1500 hours or 3 years
Vacuum pumps	Every 1200 hours
All hose	Hose carrying flammable liquids at engine overhaul or every 5 years. All other hose on condition.

FUEL SYSTEM

Fuel cells and strainer drain valves	On condition
Wing fuel quantity transmitters	On condition
Fuel cell drain valve	On condition
Fuel system check valves	On condition
Fuel selector valves	Inspect every 500 hours Overhaul every 1200 hours
Aux fuel pump	Every 1200 hours
All hose	Hose carrying flammable liquids at engine overhaul or every 5 years. All other hose on condition.
Vent line check valve	On condition

Section VIII **BEEHCRAFT Baron B55**
Handling, Serv - Maint **TC-371, TC-502 thru TC-1607**

COMPONENT **OVERHAUL OR REPLACE**
INSTRUMENTS

Turn coordinator	On condition
Altimeter	Every 24 months per FAA Directive (Inspect and Calibrate)
Directional gyro	On condition
Gyro horizon	On condition
Gyro pressure	On condition
Engine indicator units	On condition
Airspeed indicator	On condition
Rate-of-climb	On condition
Fuel pressure gage	On condition
Manifold pressure indicator	On condition
Tachometer	On condition
Free air temperature indicator	On condition
Deice pressure gage	On condition
All hose	On condition
Suction gage	On condition

ELECTRICAL SYSTEM

Dynamic brake relay	On condition
Battery master relay	On condition
Paralleling relay	On condition
All other relays	On condition
Voltage regulator	On condition
Starter	At engine overhaul or replace on condition
Starter relay	On condition
Alternator or Generator	On condition
Landing gear selector switch	1200 hours - replace

COMPONENT

OVERHAUL OR REPLACE

FLAPS AND FLIGHT CONTROLS

Flight controls	On condition
Aileron tab actuator	On condition
Elevator tab actuator	On condition
Rudder tab actuator	On condition
Flap track rollers	Every 1000 hours
Flap motor and drives	Every 2000 hours
Flap motor brushes	On condition
Flap actuators	Every 2000 hours
Flap flexible shaft	Every 2000 hours

NOTE

Any time the control surfaces are altered, repaired, or repainted, they must be rebalanced per Shop Manual.

MISCELLANEOUS

Seat belts or Shoulder Harnesses	Inspect every 12 months, replace on condition
Hand fire extinguisher	Inspect every 12 months, recharge as necessary

*Refer to Continental Service Bulletin M79-14 or later issue, for detailed overhaul period instructions.

With particular attention to throttle response, smooth power and oil consumption, a qualified certificated mechanic must determine that the engine is operating normally at the time of each periodic inspection.

SECTION IX

SUPPLEMENTS

NOTE

The supplemental data contained in this section is for equipment that was delivered on the airplane including standard optional equipment that was available, whether it was installed or not. Supplements for equipment for which the vendor obtained a Supplemental Type Certificate were included as loose equipment with the airplane at the time of delivery. These and other supplements for other equipment that was installed after the airplane was delivered new from the factory should be placed in this Supplements Section of this Pilot's Operating Handbook and FAA Approved Airplane Flight Manual.

INTENTIONALLY LEFT BLANK

Hawker Beechcraft Corporation

LOG OF SUPPLEMENTS

Baron 95-B55 and 95-B55A

Pilot's Operating Handbook
and

FAA Approved Airplane Flight Manual

P/N 96-590011-25

September, 2011

FAA Supplement must be in the airplane for all flight operations when subject equipment is installed.

PART NUMBER	SUBJECT	REV NO.	DATE
130598	Landing Gear Safety System	3	1/83
*131262	Operation In The United Kingdom	1	8/03
131391	Manual Cowl Flaps (Kit 55-9017)		6/80
55-590000-51	Goodyear Electrothermal Propeller Deice		10/78
58-590000-49	Inside Cabin Door Handle With Open/Closed Placard		12/90
95-590014-47	Goodrich Reservoir Type Pneumatic Deicing System		10/78
96-590000-1	Auxiliary Fuel Tank Annunciator Light (Kit 96-9001-1)		11/93
96-590010-19	King KN-74 Area Navigation	1	2/79
96-590010-21	Nickel-Cadmium Battery and Charge Current Detector		10/76
SA126CE	Hartzell Propellers		4/1/69

Log Of Supplements (Cont'd)
96-590011-25
September, 2011

PART NUMBER	SUBJECT	REV NO.	DATE
SA795CE	Hartzell Propellers	2	2/13/76

NOTE: Supplements applicable to equipment other than that installed may, at the discretion of the owner/operator, be removed from the manual.

** Supplements marked with an asterisk will not be supplied with handbooks sold through Authorized Raytheon Outlets due to their limited applicability. If a document is required for your airplane, please order the document through normal channels.*

**BEECHCRAFT BARON 95-B55 and 95-B55A
(TC-1024 thru TC-1607), 95-C55 and 95-C55A
(TC-350 and TE-252 thru TE-451), D55 and
D55A (TE-452 thru TE-767), E55 and E55A
(TE-768 thru TE-942, except TE-938),
58 and 58A (TH-1 thru TH-384), TRAVEL
AIR D95A (TD-680 thru TD-707, and E95
(TD-708 thru TD-721) LANDPLANES**

**PILOT'S OPERATING HANDBOOK AND
FAA APPROVED AIRPLANE FLIGHT MANUAL
SUPPLEMENT**

for the

LANDING GEAR SAFETY SYSTEM

GENERAL

This document is to be attached to the Pilot's Operating Handbook and FAA Approved Airplane Flight Manual when the airplane is equipped with the automatic extension and retraction system which has been installed in accordance with BEECHCRAFT FAA approved data.

The information in this document supersedes the Pilot's Operating Handbook and FAA Approved Flight Manual only where covered in the items contained herein.

LIMITATIONS

The landing gear safety system is designed to help prevent "gear-up" landings and premature or inadvertent operation of the landing gear mechanism. The system is to be used as safety backup device only; normal usage of the landing gear position switch is mandatory.

**FAA Approved
Revised: January, 1983
P/N 130598**

EMERGENCY PROCEDURES

In the event of an emergency, automatic extension of the landing gear may be prevented by placing the landing gear safety system ON-OFF-TEST switch in the OFF position, thus inactivating the safety system.

NORMAL PROCEDURES

PREFLIGHT CHECK:

1. Throttles - CLOSED OR RETARDED.
2. Battery master switch - ON.
3. Landing gear circuit breaker - either IN or OUT.
4. Place the ON-OFF-TEST switch in the TEST position. Proper functioning of the automatic landing gear extension portion of the system is indicated by the noise or movement of the solenoid in the landing gear position switch. The ON-OFF-TEST switch returns normally to the ON position unless the pilot places the switch in the OFF position.
5. Landing gear circuit breaker - IN before take-off.

OPERATION

1. Landing Gear Extension - With the landing gear safety system ON-OFF-TEST switch in the ON position the landing gear will be automatically extended when: (1) the airspeed is below approximately 104 kts/120 mph IAS and (2) both engines are operating at a throttle position corresponding to approximately 17 inches or less of manifold pressure.

FAA Approved
Revised: January, 1983
P/N 130598

2. Landing Gear Retraction - With the landing gear safety system ON-OFF-TEST switch in the ON position, the landing gear will not retract unless: (1) the landing gear position switch is in the UP position (2) the airspeed is above approximately 61 kts/70 mph IAS and (3) one engine is operating at a throttle position corresponding to approximately 19 inches or more of manifold pressure.

NOTE

If landing gear retraction is desired before the indicated airspeed reaches approximately 61 kts/70 mph, the landing gear safety system must be inactivated by placing the ON-OFF-TEST switch in the OFF position, preferably before placing the landing gear position switch in the UP position.

PERFORMANCE - No change

Approved:

Donald H. Peter

For

W. H. Schultz
Beech Aircraft Corporation
DOA CE-2

Raytheon Aircraft Company

Beechcraft

Baron® 95-B55 and 95-B55A

Pilot's Operating Handbook and FAA Approved Airplane Flight Manual Supplement

for
Operation In The United Kingdom

*This Supplement is Applicable to the Following
Manual(s):*

96-590011-23

96-590011-25

Airplane Serial Number: _____

Airplane Registration Number: _____

FAA Approved by:



John Tighe

Raytheon Aircraft Company

DOA-230339-CE

Copyright © Raytheon Aircraft Company 2003

Revised: August, 2003

P/N 131262

1 of 8

Raytheon Aircraft Company

LOG OF REVISIONS

Baron® 95-B55 and 95-B55A

Pilot's Operating Handbook
and

FAA Approved Airplane Flight Manual
Supplement

for
Operation In The United Kingdom

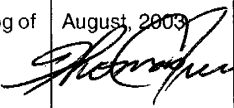
REV NO.	PAGE NO(S).	DESCRIPTION	DATE OF REV
0	1 thru 4	Original Issue	February 2, 1974
1	1 thru 8	Revised Format; Added Log of Revisions page; Revised Limitations.	August, 2003 

CONTENTS

SECTION I - GENERAL	Page 3
SECTION II - LIMITATIONS	Page 3
SECTION III - EMERGENCY PROCEDURES	Page 5
SECTION IV - NORMAL PROCEDURES	Page 6
SECTION V - PERFORMANCE	Page 6
SECTION VI - WT AND BAL/EQUIP LIST.	Page 8
SECTION VII - SYSTEMS DESCRIPTION	Page 8
SECTION VIII - HANDLING, SERV & MAINT	Page 8

SECTION I - GENERAL

The information in this supplement is FAA-approved material and must be attached to the Pilot's Operating Handbook and FAA Approved Airplane Flight Manual (POH/AFM) when the airplane is operating in the United Kingdom.

The information in this supplement supersedes or adds to the basic POH/AFM only as set forth below. Users of the manual are advised to always refer to the supplement for possibly superseding information and placarding applicable to operation of the airplane.

SECTION II - LIMITATIONS

CERTIFICATION CATEGORY

The Barons B55 and B55A (Special Export Configuration) are eligible for certification in the United Kingdom in the General Purpose Category. This particular aeroplane may, however, be restricted to the Special Category and to a particular use and this will be stated in the Certificate of Airworthiness.

PERFORMANCE

When certified in the General Purpose Category, the aeroplane is classified in Performance Group E. For the purpose of establishing compliance with the Air Navigation Performance Group E Regulations, the Performance Data in the Pilot's Operating Handbook and FAA Approved Airplane Flight Manual P/N 96-590011-23 or 96-590011-25, except as modified by this supplement, are to be used.

CRUISE

For the purpose of compliance with the legislation governing Flight Over Water, the True Airspeed to be assumed is 175 knots.

CREW AND OCCUPANTS

The minimum crew is one pilot.

The total number of persons carried shall not exceed 6 nor exceed the number for which seating accommodation approved for use during takeoff and landing is provided. Children under the age of three years who are carried in the arms of passengers may be left out of account for this purpose. The standard seating capacity is 4, but can optionally be equipped with 5 or 6 seats.

AIR TEMPERATURE

The maximum air temperature for scheduled operation is ISA + 23°C. No minimum temperature has been established.

TYPE OF OPERATION

The aeroplane shall not be flown at night unless the required equipment is carried and it is permitted by the Air Navigation Legislation.

All flights under heavy icing conditions or extended flights under moderate icing conditions are prohibited.

Flight into areas of light-to-moderate icing conditions should be undertaken with caution only when the essential equipment for extended flight under light icing conditions is available.

Flight under moderate icing conditions for short periods of time and extended flight under light icing conditions has been demonstrated as satisfactory only when the essential equipment listed below is available.

1. Deicer boots on wing and empennage leading edge surfaces.
2. Heated pitot tube mast and fuel tank vents.
3. Alternate static source.
4. Dual vacuum sources for flight instruments (standard equipment).
5. Propeller anti-icing system.
6. Windscreen anti-icing system when landings under icing conditions are anticipated.

AUTOMATIC PILOT

Minimum permissible altitudes with Century III or IV Automatic Pilots engaged are:

Cruise 1000 FEET ABOVE TERRAIN

Coupled to ILS

Glideslope Localizer 350 FEET ABOVE TERRAIN

SECTION III - EMERGENCY PROCEDURES

No Change

SECTION IV - NORMAL PROCEDURES

FLAPLESS LANDING

Manoeuvre to final approach maintaining 10 knots above the Approach Speed appropriate to the weight shown in the Normal Landing Distance chart. Extend the landing gear. Maintain this speed down to the 50 foot height point.

SECTION V - PERFORMANCE

TAKE-OFF DISTANCE

Take-off distance over 50 foot obstacle is shown for varying air temperatures, aerodrome altitude, weights, and reported wind components. The associated conditions, take-off speeds, example, and notes are presented directly on the graph. The air minimum single engine control speed with flaps up, clear of ground effect and with 5° of bank toward the live engine is 78 knots IAS.

TAKE-OFF DISTANCE

Replaces Normal Take-off Distance graph for Operations in the UNITED KINGDOM

ASSOCIATED CONDITIONS:

POWER TAKE-OFF POWER SET BEFORE BRAKE RELEASE
 FLAPS UP
 RUNWAY PAVED LEVEL DRY SURFACE
 TAKEOFF SPEED IAS AS TABULATED

WEIGHT POUNDS	IAS TAKE-OFF SPEED (ASSUMES ZERO INST. ERROR)
	KNOTS
5100	91
4800	88
4400	87
4000	87

EXAMPLE:

OAT 20°C
 PRESSURE ALTITUDE 2000 FT
 TAKE-OFF WEIGHT 4850 LBS
 HEAD WIND 10 KNOTS

TOTAL TAKE-OFF DISTANCE OVER 50 FT OBSTACLE 2020 FT
 AS TAKE-OFF SPEED 88 KNOTS

NOTES:

- GROUND ROLL WILL NOT EXCEED 75% OF TOTAL TAKE-OFF DISTANCE OVER 50 FT OBSTACLE.
- THE TOTAL DISTANCES SHOWN OVER 50 FT SHOULD BE INCREASED 18% FOR OPERATION ON SHORT DRY GRASS WITH A FIRM SUBSOIL.
- THE WIND CORRECTION GRIDS ARE FACTORED SO THAT 50% OF HEAD WINDS AND 150% OF TAIL WINDS ARE OBTAINED. REPORTED WINDS MAY THEREFORE BE USED DIRECTLY IN THE GRIDS.

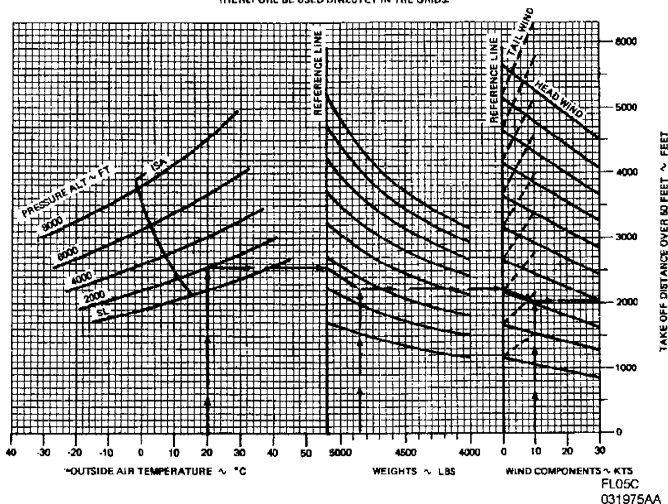

SECTION VI - WEIGHT & BALANCE/EQUIP- MENT LIST

No Change

SECTION VII - SYSTEMS DESCRIPTION

No Change

SECTION VIII - HANDLING, SERVICING AND MAINTENANCE

No Change

**BEEHCRAFT BARON 95-55, 95-A55 and 95-B55
LANDPLANES (TC-1 thru TC-1607)
PILOT'S OPERATING HANDBOOK AND FAA
APPROVED AIRPLANE FLIGHT MANUAL
SUPPLEMENT
FOR
MANUAL COWL FLAPS
(BEECH KIT NO. 55-9017)**

GENERAL

The information in this supplement is FAA-Approved material and must be attached to the Pilot's Operating Handbook and FAA Approved Airplane Flight Manual when the airplane has been modified by installation of manual cowl flaps in accordance with Beech-approved data.

The information in this supplement supersedes or adds to the basic Pilot's Operating Handbook and FAA Approved Airplane Flight Manual only as set forth within this document. Users of this manual are advised always to refer to the supplement for possibly superseding information and placarding applicable to operation of the airplane.

LIMITATIONS - No change

EMERGENCY PROCEDURES - No change

NORMAL PROCEDURES

BEFORE STARTING

1. Seats - POSITION AND LOCK SEAT BACKS UPRIGHT

**FAA Approved
Issued: June, 1980
P/N 131391**

2. Seat Belts - FASTEN
Shoulder Harnesses if installed - FASTEN
3. Parking Brake - SET
4. All Avionics - OFF
5. Oxygen - CHECK QUANTITY AND OPERATION
6. Landing Gear Handle - DOWN
7. Cowl Flaps - CHECK, OPEN
8. Fuel Selector Valves - CHECK OPERATION THEN
SET TO MAIN
9. All Circuit Breakers, Switches and Equipment Controls
- CHECK
10. Battery Switch - ON

CAUTION

The generator/alternator control switches must be turned OFF prior to connecting an auxiliary power unit for starting, battery charging or electrical equipment check-out. This procedure protects the voltage regulators and system electrical equipment from voltage transients (power fluctuations).

11. Fuel Quantity Indicators - CHECK QUANTITY, MAIN
AND AUXILIARY. Fuel quantity selector switch to
MAIN. (See LIMITATIONS for take-off fuel)
12. Landing Gear Position Lights - CHECK

PERFORMANCE - No change

WEIGHT AND BALANCE - No change

FAA Approved
Issued: June, 1980
P/N 131391

SYSTEMS DESCRIPTION

COWL FLAPS

The push-pull cowl flap control for each engine is located on the lower center console. The cowl flap is closed when the control is pushed in and open when the control is pulled out.

HANDLING, SERVICING AND MAINTENANCE - No change

APPROVED

Donald St Peter

for

W. H. Schultz
Beech Aircraft Corporation
BOA CE-2

BEECHCRAFT LANDPLANES

MODEL 95-55 SERIES

PILOT'S OPERATING HANDBOOK AND FAA APPROVED AIRPLANE FLIGHT MANUAL SUPPLEMENT

for the

GOODYEAR ELECTROTHERMAL PROPELLER DEICE

GENERAL

The information in this supplement is FAA approved material and must be attached to the Pilot's Operating Handbook and FAA Approved Airplane Flight Manual when the airplane is equipped with a Goodyear Electrothermal Propeller Deice System that has been installed in accordance with BEECHCRAFT FAA approved data.

This document supersedes or adds to the Pilot's Operating Handbook and FAA Approved Airplane Flight Manual only where covered in the items contained herein.

LIMITATIONS

Do not operate the system unless engine is operating.

Airplanes equipped with approved emergency static air source, surface deicing systems, pitot heat, heated stall warning, windshield defogging or storm windows, and external antenna mast capable of withstanding ice load are considered to be equipped for flight into icing conditions as governed by operational practices of Bureau of Flight Standards Release No. 434. When not equipped accordingly a placard as shown must be installed.

FAA Approved

Revised: October, 1978

P/N 55-590000-51

1 of 4

PLACARDS

On Instrument Panel:

**WARNING
THIS AIRCRAFT IS NOT FULLY EQUIPPED
FOR FLIGHT IN ICING CONDITIONS**

EMERGENCY PROCEDURES

1. Loss of one generator, off-load unnecessary electrical equipment. Turn off the propeller deice system while operating the cabin heater blower or the landing gear motor. Monitor electrical loads so as not to exceed generator capacity.

2. Abnormal Reading on Propeller Deice Ammeter

a. Zero Amps

Check propeller deice switch. If the circuit breaker in the switch has tripped, a wait of approximately 30 seconds is necessary before resetting the switch to the ON position. If ammeter reads 0 and switch has not tripped or if ammeter still reads 0 after the switch has been reset, turn the switch off and consider the propeller deice system inoperative.

b. Zero to 7 Amps

If propeller deice system ammeter occasionally or regularly indicates less than 7 amps, operation of the propeller deice system can continue unless serious propeller imbalance results from irregular ice throw-offs.

**FAA Approved
Revised: October, 1978
P/N 55-590000-51**

c. 11 to 15 Amps

If propeller deice system ammeter occasionally or regularly indicates 11 to 15 amps, operation of the propeller deice system can continue unless serious propeller imbalance results from irregular ice throw-offs.

d. More than 15 Amps

If the propeller deice system ammeter occasionally or regularly indicates more than 15 amps, the system should not be operated unless the need for propeller deice is urgent.

NORMAL PROCEDURES

WARNING

To minimize slip ring pitting, do not operate the system with engines inoperative.

PREFLIGHT

1. With engines operating, place propeller deice switch in the ON position.
2. Check propeller deice system ammeter for reading of 7 to 11 amperes.
3. A small momentary deflection of the needle may be noticed approximately every 30 seconds: This is due to the switching action of the timer and is an indication of normal operation of the system.

IN FLIGHT

1. To place the system in operation, move propeller deice switch to the ON position. The system may be operated continuously in flight and will function automatically until the switch is turned off.
2. Propeller imbalance may be relieved by varying rpm. Increase rpm briefly and return to desired setting, repeating if necessary.

PERFORMANCE - No change

Approved:

for *Donald St Peter*
Chester A. Rembleske
Beech Aircraft Corporation
DOA CE-2

BEECHCRAFT SERIES 33,35,36,55,58

**PILOT'S OPERATING HANDBOOK AND FAA
APPROVED AIRPLANE FLIGHT MANUAL
SUPPLEMENT**

FOR

**INSIDE CABIN DOOR HANDLE WITH OPEN/
CLOSED PLACARD**

**THIS SUPPLEMENT IS APPLICABLE TO PILOT'S
OPERATING HANDBOOKS AND FAA APPROVED
AIRPLANE FLIGHT MANUALS:**

(SEE NEXT PAGE FOR APPLICABILITY)

Airplane Serial Number: _____

Airplane Registration Number: _____

FAA Approved:



W. H. Schultz
Beech Aircraft Corporation
DOA CE-2

COPYRIGHT © BEECH 1990

This supplement applies to the following Pilot's Operating Handbooks and FAA Approved Airplane Flight Manuals:

MODEL	PART NUMBER	A/C SERIALS
35-B33	33-590000-17B	All
35-C33, E33, F33	33-590002-9B	All
35-C33A, E33A, E33C	33-590003-7B	All
F33A, F33C	33-590009-13	CE-674 & after, CJ-129 & after
F33A, F33C	33-590009-15	CE-290 thru CE- 673, CJ-26 thru CJ-128
G33	33-590027-3	All
F35	35-590071-13	All
G35	35-590072-9	All
H35	35-590073-15	All
N35, P35	35-590094-7	All
S35-TC	35-590110-3	All
S35	35-590110-11B	All
V35-TC	35-590113-3	All
V35A-TC	35-590116-3	All
V35B-TC	35-590118-23	D-9069 thru D- 9947
V35B	35-590118-29	D-9948 & after
V35, V35A, V35B	35-590118-31B	D-7977 thru D- 9947
A36	36-590002-17	E-927 thru E-2110 except E-1946 & E-2104
36, A36	36-590002-19C	E-1 thru E-926
A36	36-590002-37	E-1946, E-2104, E- 2111 & after
A36-TC	36-590003-3	EA-1 thru EA-272 except EA-242

MODEL	PART NUMBER	A/C SERIALS
B36-TC	36-590006-3	EA-242, EA-273 thru EA-388 except EA-326
B36-TC	36-590006-19	EA-326, EA-389 & after
95-B55B	55-590000-49	All
95-55, 95-A55	55-590000-65B	TC-1 thru TC-501 except TC-350 & TC-371
58, 58A	58-590000-21	TH-773 thru TH- 1395 except TH- 1389
58, 58A	58-590000-31B	TH-1 thru TH-772
58, 58A	58-590000-35	TH-1389, TH-1396 thru TH-1471, TH- 1476, TH-1487, TH- 1489, TH-1498
58, 58A	58-590000-39	TH-1472 & after, except TH-1476, TH-1487, TH-1489, TH-1498
E55, E55A	96-590010-17	TE-1084 & after
95-C55, 95-C55A, D55, D55A, E55, . E55A	96-590010-29B	TC-350, TE-1 thru TE-942, except TE-938
E55, E55A	96-590010-31	TE-938, TE-943 thru TE-1083
E55, E55A	96-590010-37	TE-1197 only
95-B55, 95-B55A	96-590011-17	TC-2003 & after
95-B55, 95-B55A	96-590011-23	TC-1608 thru TC- 2002
95-B55, 95-B55A	96-590011-25	TC-371, TC-502 thru TC-1607
58TC	106-590000-5	TK-1 thru TK-84
58TC, 58TCA	106-590000-19	TK-85 thru TK-150, except TK-147

MODEL	PART NUMBER	A/C SERIALS
58TC, 58TCA	106-590000-21	TK-147, TK-151 & after

CONTENTS

GENERAL	Page 5
LIMITATIONS	Page 5
EMERGENCY PROCEDURES	Page 6
NORMAL PROCEDURES	Page 6
PERFORMANCE	Page 6
WEIGHT & BALANCE	Page 6
SYSTEMS DESCRIPTION	Page 6
HANDLING, SERVICING & MAINTENANCE ...	Page 7

GENERAL

The information in this supplement is FAA-approved material and must be attached to the Pilot's Operating Handbook and FAA Approved Airplane Flight Manual when the airplane has been modified by installation of the Inside Cabin Door Handle With Open/Closed Placard in accordance with Beech Kit 35-5050.

The information in this supplement supersedes or adds to the basic Pilot's Operating Handbook and FAA Approved Airplane Flight Manual only as set forth below. Users of the manual are advised to always refer to the supplement for possibly superseding information and placarding applicable to operation of the airplane.

LIMITATIONS

PLACARDS

On inside of Cabin Door Adjacent to Door Handle:

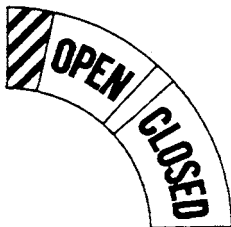

EMERGENCY PROCEDURES

No change.

NORMAL PROCEDURES

BEFORE TAKEOFF

All procedures specified in the Pilot's Operating Handbook and FAA Approved Airplane Flight Manual for the particular airplane shall be completed. In addition, accomplish the following:

- Doors and Windows - SECURE (Check cabin door lock indicator - CLOSED)

PERFORMANCE

No change.

WEIGHT AND BALANCE

No change.

SYSTEMS DESCRIPTION

DOORS, WINDOWS AND EXITS

CABIN DOOR

The airplane has a conventional cabin door on the forward right side of the fuselage and when closed, the outside cabin door handle is spring loaded to fit into a recess in the door to create a flat aerodynamically clean surface. The door may be locked with a key. To open the door from the outside, lift the handle from its recess and pull until the door opens.

To close the cabin door from the inside, observe that the door handle is in the open position. In this position, the latch handle is free to move approximately one inch in either direction before engagement of the locking mechanism. Then grasp the door and firmly pull the door closed. Rotate the door handle fully counterclockwise into the locked position. Observe that the door handle indicator is in the CLOSED position. When the door is properly locked, the door latch handle is free to move approximately one inch in either direction.

NOTE

When checking the door latch handle, do not move it far enough to engage the door latch release mechanism.

Press firmly outward at the top rear corner of the door. If any movement of the door is detected, completely open the door and close again following the above instructions.

To open the door from the inside, depress the lock button and rotate the handle clockwise.

HANDLING, SERVICING, AND MAINTENANCE

No change.

**BEECHCRAFT 95 and 95-55
SERIES LANDPLANES**

**PILOT'S OPERATING HANDBOOK AND
FAA APPROVED AIRPLANE FLIGHT MANUAL
SUPPLEMENT**

for the

**GOODRICH RESERVOIR TYPE
PNEUMATIC DE-ICING SYSTEM**

GENERAL

This document is to be attached to the Pilot's Operating Handbook and FAA Approved Airplane Flight Manual when the airplane is equipped with a Goodrich Reservoir Type Pneumatic De-Icing System in accordance with BEECHCRAFT FAA approved data.

LIMITATIONS

1. Stall speeds are increased 4 kts/5 mph in all configurations with de-icers operating.
2. System capacity.

RESERVOIR PRESSURE (PSIG)	CYCLES AVAILABLE	ENDURANCE AT ONE CYCLE PER THREE MINUTES
100	4	12 min
500*	22	1 hr 6 min
1000	44	2 hrs 12 min
1500	66	3 hrs 18 min
2000	89	4 hrs 27 min
2500	112	5 hrs 3 min
3000**	134	6 hrs 42 min

*Recharge reservoir

**Maximum operating pressure

**FAA Approved
Revised: October, 1978
P/N 95-590014-47**

1 of 3

3. System endurance

The above table is presented so that the operator may estimate system endurance in time or cycles remaining. Use of the system is on a demand basis rather than a cycle basis. (1/4" to 1/2" of ice buildup rather than cycling at specific time intervals - demand cycling to be no more frequent than once every three minutes).

4. Instrument markings

De-icer pressure: Low pressure gage: Green arc,
15 to 25 psi.
High pressure gage: Red line,
3000 psi.

EMERGENCY PROCEDURES

For manual emergency deflation of the de-icers:
Cycling control valve - PUSH IN

NORMAL PROCEDURES

PREFLIGHT CHECK:

1. Observe reservoir pressure. Gage indicates only when air supply valve is open. Recharge reservoir if below 500 psi (reservoir pressure should be at least 500 psi).
2. Observe low pressure gage. Gage should indicate 15-25 psi. Reset and lock regulator if necessary.
3. Actuate cycling valve and observe De-icer inflation.
4. Observe deflation of De-icers. Deflation should be rapid and complete.

FAA Approved
Revised: October, 1978
P/N 95-590014-47

CAUTION

Vacuum source for De-icers is the right engine-driven vacuum pump. If the right engine is not operating, vacuum is not available. De-icers will deflate under this condition, but will not reach a vacuum "holddown" condition.

5. Normal inflation and deflation time is five to eight seconds.
6. Close remotely operated reservoir air supply valve.

OPERATION

1. When de-icing is required, pull "air supply" control to "arm" system; then pull de-icer "cycle control" for each cycle desired.
2. After 1/4" to 1/2" of ice buildup on leading edges, actuate cycling valve. When de-icers become fully inflated, the cycling valve will snap shut connecting the de-icer and the vacuum lines, deflating the system. Refer to OPERATING LIMITATIONS for system endurance; after each cycle is completed push control in to re-arm for next cycle. Sufficient pressure should be reserved to cycle the boots prior to landing.
3. When de-icing is no longer required, close remotely operated reservoir air supply valve.

PERFORMANCE - No change

Approved:

for 

Chester A. Rembleske
Beech Aircraft Corporation
DOA CE-2

FAA Approved
Revised: October, 1978
P/N 95-590014-47

3 of 3

**BEECHCRAFT BARON LANDPLANES
PILOT'S OPERATING HANDBOOK
AND FAA APPROVED
AIRPLANE FLIGHT MANUAL SUPPLEMENT**

FOR THE

**AUXILIARY FUEL TANK ANNUNCIATOR LIGHT
(BEECH KIT NO. 96-9001-1)**

PILOT'S OPERATING HANDBOOKS AFFECTED:

Baron 95-55/95-A55
(TC-1 thru TC-501 except TC-350 and TC-371)
..... P/N 55-590000-65

Baron 95-B55/95-B55A
(TC-371 and TC-502 thru TC-1607)
..... P/N 96-590011-25

Baron 95-C55/95-C55A, D55/D55A, E55/E55A
(TC-350 and TE-1 thru TE-942 except TE-938)
..... P/N 96-590010-29

Airplane Serial Number: _____

Airplane Registration Number: _____

Approved:

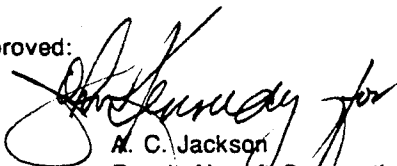

A. C. Jackson
Beech Aircraft Corporation
DOA CE-2

**FAA Approved
Issued: November, 1993
P/N 96-590000-1**

CONTENTS

GENERAL	Page 2
LIMITATIONS	Page 3
EMERGENCY PROCEDURES	Page 3
NORMAL PROCEDURES	Page 4
PERFORMANCE	Page 4
WEIGHT & BALANCE	Page 4
SYSTEMS DESCRIPTION	Page 5
HANDLING, SERVICING, AND MAINTENANCE	Page 5

GENERAL

This document must be attached to the Pilot's Operating Handbook and FAA Approved Airplane Flight Manual when the airplane has been modified by the installation of the Auxiliary Fuel Tank Annunciator Light in accordance with Beech Kit 96-9001-1.

The information in this supplement supersedes or adds to the basic Pilot's Operating Handbook and FAA Approved Airplane Flight Manual only as set forth within this document. Users of this manual are advised always to refer to the supplement for possibly superseding information and placarding applicable to the operation of the airplane.

FAA Approved
Issued: November, 1993
P/N 96-590000-1

LIMITATIONS

PLACARDS

On Instrument Panel:

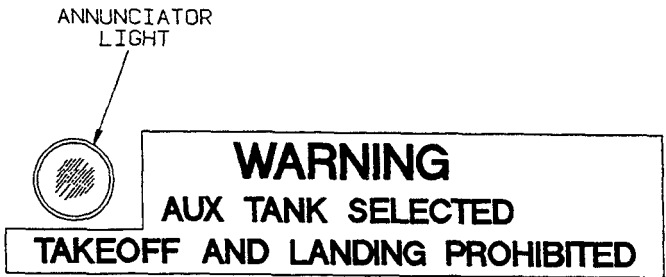

C93TD00C1170

EMERGENCY PROCEDURES

No Change.

NORMAL PROCEDURES

BEFORE STARTING

- Battery Switch and Generator Switches- ON (If external power is used, Generator Switches - OFF)

- Fuel Selector Valves - CHECK OPERATION, THEN SET TO MAIN TANKS
 - Left Aux Tank Selected - AUX TANK SELECTED annunciator light CHECK ILLUMINATED
 - Left Main Tank Selected - AUX TANK SELECTED annunciator light CHECK EXTINGUISHED
 - Right Aux Tank Selected - AUX TANK SELECTED annunciator light CHECK ILLUMINATED
 - Right Main Tank Selected - AUX TANK SELECTED annunciator light CHECK EXTINGUISHED

PERFORMANCE

No Change.

WEIGHT & BALANCE

No Change.

FAA Approved
Issued: November, 1993
P/N 96-59000-1

SYSTEMS DESCRIPTION

FUEL SYSTEM

AUXILIARY FUEL TANK ANNUNCIATOR LIGHT

When BEECH Kit 96-9001-1 is installed, a red auxiliary fuel tank annunciator light will illuminate if either one of the auxiliary fuel tanks is selected when the landing gear is extended. Auxiliary fuel tanks are to be used during level flight only and not during takeoff or landing.

HANDLING, SERVICING, AND MAINTENANCE

No Change.

**BEECHCRAFT BARONS 95-B55,
95-B55A, E55, E55A, 58, 58A LANDPLANES**

**PILOT'S OPERATING HANDBOOK AND
FAA APPROVED AIRPLANE FLIGHT MANUAL
SUPPLEMENT**

for the

**KING KN-74
AREA NAVIGATION SYSTEM**

GENERAL

The information in this supplement is FAA approved material and must be attached to the Pilot's Operating Handbook and FAA Approved Airplane Flight Manual when the airplane is equipped with a King KN-74 Area Navigation System which has been installed in accordance with BEECHCRAFT FAA approved data.

The information in this supplement supersedes or adds to the basic Pilot's Operating Handbook and FAA Approved Airplane Flight Manual only as set forth below.

LIMITATIONS

1. This system shall not be used as a primary system under IFR conditions except on approved approach procedures, approved area navigation airways, and random area navigation routes when approved by Air Traffic Control.

2. This system is to be used only with collocated facilities (VOR and DME signals originate from the same geographical location).

FAA Approved
Revised: February, 1979
P/N 96-590010-19

EMERGENCY PROCEDURES

CAUTION

DME may unlock due to loss of signal with certain combinations of distance from station, altitude, and angle of bank.

1. VOR or Distance flag appears while in RNAV mode:
 - a. Selected Frequency - CHECK FOR CORRECT FREQUENCY
 - b. VOR or Distance Flag Intermittent or Lost - UTILIZE OTHER NAV EQUIPMENT AS REQUIRED
2. VOR or Distance flag appears while in APPR mode:
 - a. If flag appears while in an approach, execute published missed approach and utilize other approved facility.

NORMAL PROCEDURES

1. VHF NAV - ON
2. DME - ON
3. Mode Selector - SELECT VOR/DME, RNAV, or APPR
4. NAV Frequency - SET
5. DME Frequency - SET
6. Waypoint Bearing - SET WAYPOINT RADIAL FROM VORTAC
7. Waypoint Distance - SET WAYPOINT DISTANCE FROM VORTAC
8. OBS Control - DESIRED MAGNETIC HEADING
9. Self-Test - PRESS BUTTON (must have VOR reception)

FAA Approved
Revised: February, 1979
P/N 96-590010-19

PERFORMANCE - No change

Approved:

for 
W. H. Schultze
Beech Aircraft Corporation
DOA CE-2

**BEEHCRAFT BARONS 95-B55,
95-B55A, E55, E55A, 58, 58A LANDPLANES**

**PILOT'S OPERATING HANDBOOK AND
FAA APPROVED AIRPLANE FLIGHT MANUAL
SUPPLEMENT**

for the

**NICKEL-CADMIUM BATTERY
AND
CHARGE CURRENT DETECTOR**

GENERAL

The information in this supplement is FAA Approved material and must be attached to the Pilot's Operating Handbook and FAA Approved Flight Manual when the airplane is equipped with a Nickel-Cadmium Battery and Charge Current Detector installed in accordance with BEEHCRAFT FAA approved data.

The Battery Charge Current Detector consists of a circuit which illuminates an amber light on the instrument panel whenever the battery charge current is above normal. The system is designed for a continuous monitor of battery condition.

The purpose of the Battery Charge Current Detector is to inform the pilot of battery charge currents which may damage the battery. The system senses all battery current and provides a visual indication of above normal charge current. Following a battery engine start, the battery recharge current is very high and causes the illumination of the BATTERY CHARGE light, thus providing an automatic self test of the detector and the battery. As the battery approaches a full charge and the charge current decreases to a satisfactory amount, the light will extinguish. This will normally occur within a few minutes after an engine start, but may

require a longer time, if the battery has a low state of charge, low charge voltage per cell (20 cells battery), or low battery temperature.

The light may occasionally reappear for short intervals when heavy loads switch off, or engine speeds are varied near generator cut-in speed. High battery temperatures or high charge voltage per cell will result in a high overcharge current which will eventually damage the battery and lead to thermal runaway. Illumination of the BATTERY CHARGE light in flight alerts the pilot that conditions may exist that may eventually damage the battery. The battery should be turned off to prevent battery damage. The following procedures outline the actions to be taken in the event the BATTERY CHARGE light illuminates.

EMERGENCY PROCEDURES

DURING CRUISE

The illumination of the amber caution light, placarded BATTERY CHARGE, in flight indicates a possible malfunction of the battery. Turn the Battery Switch - OFF. The caution light should extinguish and the flight may proceed to destination. Failure of the light to extinguish with the battery switch off indicates a battery system or a charge current detector system malfunction. The aircraft should be landed as soon as practicable. (The battery switch should be turned on for landing in order to avoid electrical transients caused by power fluctuations.) After landing perform a During Shutdown Battery Condition check.

NORMAL PROCEDURES

BEFORE STARTING ENGINES

1. Caution Light (BATTERY CHARGE) - PRESS TO TEST for illumination.

DURING ENGINE START

Provided sufficient energy is used from the battery during the first engine start, the amber caution light, placarded **BATTERY CHARGE**, will illuminate approximately 6 seconds after the generator is on the line. This indicates a charge current above normal. The light should extinguish within 5 minutes. Failure to do so indicates a partially discharged battery. Continue to charge battery. Make a check each 90 seconds using the procedure outlined below until the charge current fails to decrease and the light extinguishes. Failure of the light to extinguish indicates an unsatisfactory condition. The battery should be removed and checked by a qualified Nickel-Cadmium Battery shop.

1. One Alternator/Generator - OFF.
2. Engine Speed (Engine with Alternator/Generator On) - 1000 RPM (Voltmeter indicating approximately 28 volts).
3. After loadmeter needle stabilizes, momentarily turn the battery switch off and note the change in meter indication.

NOTE

The change in load meter indications is the battery charge current and should be no more than .025 (only perceivable needle movement) within 5 minutes. Failure to obtain a reading below .025 within 5 minutes indicates a partially discharged battery. Continue to charge battery repeating the check each 90 seconds until the charge current decreases below .025. No decrease of current between checks indicates an unsatisfactory condition. The battery should be removed and checked by a qualified Nickel-Cadmium Battery shop.

DURING SHUTDOWN

Battery - CONDITION AND CHARGE (If the BATTERY CHARGE light is extinguished, the battery is charged and the condition is good. If the light is illuminated and fails to extinguish within 3 minutes of charging, perform the following check:

1. One Alternator/Generator - OFF.
2. Engine Speed (Engine with Alternator/Generator ON) - 1000 RPM (Voltmeter indicating approximately 28 volts).
3. After loadmaster needle stabilizes, momentarily turn the battery switch off and note change in meter indication.

NOTE

The change in loadmeter indication is the battery charge current and should be no more than .025 (only perceivable needle movement). If the result of this check is not satisfactory, allow the battery to charge repeating the check each 90 seconds. If the results are not satisfactory within 3 minutes, the battery should be removed and checked by a qualified Nickel-Cadmium Battery shop.

PERFORMANCE - No change

Approved:



for
Chester A. Rembleske
Beech Aircraft Corporation
DOA CE-2

FAA Identification _____
Airplane Serial No. _____

Hartzell Propeller, Inc.
AIRPLANE FLIGHT MANUAL SUPPLEMENT
For

Beech Model 95-55, 95-A55, & 95-B55 Landplanes

THIS SUPPLEMENT MUST BE ATTACHED TO THE FAA APPROVED AIRPLANE FLIGHT MANUAL WHEN HARTZELL PROPELLERS PER STC SA126CE ARE INSTALLED. APPLICABLE WITH CONTINENTAL IO-470-L ENGINES INSTALLED. INFORMATION CONTAINED HEREIN SUPPLEMENTS OR SUPERSEDES CORRESPONDING INFORMATION IN THE BASIC AIRPLANE FLIGHT MANUAL.

I LIMITATIONS

C. Propellers:

Two Hartzell constant-speed, full feathering, three-bladed propellers.

Hubs: HC-A3XF-2B or PHC-A3XF-2B or HC-A3VF-2B or PHC-A3VF-2B

Blades: 7636D or V7636D

Spinner Assembly: 836-36 or 836-37

Governor: 210355 or 210438

Pitch Settings at 30 inch station: Low 13.0° to 13.5°
High 84.0° to 86.0°

Diameter: 76½ inches maximum, no cut-off permitted.

G. Flight Load Factors:

At design gross weight: 4880 pounds - Models 95-55 & 95-A55
5100 pounds - Model 95-B55

Maneuver: Positive 4.06 "g"
Negative 2.77 "g"

Gust: Same as Basic Manual.

(The reduction in maneuver load factors to those shown in the basic Airplane Flight Manual is to compensate for the additional weight of the Hartzell propellers.)

II PROCEDURES

B. Emergency Procedures:

1. Single-engine procedures and speeds are identical to those in the basic Airplane Flight Manual.

FAA Identification. _____

Airplane Serial No. _____

LII PERFORMANCE

The performance information in the basic Airplane Flight Manual is applicable to these airplanes with Hartzell propellers.

DATE Apr. 1, 1969

APPROVED

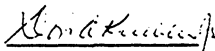

for
JOHN A. CARRAN
Chief, Engineering and
Manufacturing Branch
Federal Aviation Agency
Central Region

HARTZELL PROPELLER, INC.
350 WASHINGTON AVE.
PIQUA, OHIO

FAA APPROVED AIRPLANE FLIGHT MANUAL SUPPLEMENT
FOR
BEECH MODELS 95-55, 95-A55, 95-B55, 95-B55A, & 95-B55B
WITH HARTZELL PROPELLERS PER STC SA795CE

REG. NO. _____

SER. NO. _____

THIS DOCUMENT MUST BE ATTACHED TO THE FAA APPROVED AIRPLANE FLIGHT MANUAL WHEN HARTZELL PROPELLERS ARE INSTALLED PER STC SA795CE. INFORMATION CONTAINED HEREIN SUPPLEMENTS OR SUPERSEDES CORRESPONDING INFORMATION IN THE BASIC AIRPLANE FLIGHT MANUAL.

I. LIMITATIONS

C. PROPELLERS:

1. Hartzell constant-speed, three-bladed propeller (85 lbs. @ Station +18, or 89 lbs. for propellers designated "H").
Hubs: PHC-C3YF-2 or PHC-C3YF-2F or PHC-C3YF-2U or PHC-C3YF-2UF
Blades: C7663-2R or FC7663-2R
Spinner: C-3567-1 (5 lb. @ Station -13)
Governor: Woodward 210355, B210438 or 210666
Pitch Settings at 30 inch station: Low 13.5° - High 84°
Diameter: Not over 76 inches, not under 74.5 inches.

OR

2. Hartzell constant-speed, two-bladed propeller (62 lbs. @ Station +18, or 66 lbs. for propellers designated "H").
Hubs: BHC-C2YF-2CH or BHC-C2YF-2CHU or DHC-C2YF-2CH or DHC-C2YF-2CHU or BHC-C2YF-2CHF or BHC-C2YF-2CHUF or DHC-C2YF-2CHF or DHC-C2YF-2CHUF
Blades: C8465-6 or FC8465-6
Spinners: C-2285-1 or C-2285-6 (5 lbs. @ Station +18)
Governor: Woodward 210355, B210438 or 210666
Pitch Settings at 30 inch station: Low 16.0° - High 30°
Diameter: Not over 78 inches, not under 76.5 inches.

FAA APPROVED

FOR

Richard A. Paul
Keith D. Anderson, Chief
Eng. & Mfg. Br. Great Lakes Region
Des Plaines, Illinois
Date: 2/13/76

SECTION X
SAFETY INFORMATION
TABLE OF CONTENTS

<i>SUBJECT</i>	<i>PAGE</i>
Introduction	3
General	5
Do's	5
Don'ts	6
Sources of Information	7
Pilot's Operating Handbook and FAA Approved Airplane Flight Manual	7
BEECHCRAFT Service Publications	7
Federal Aviation Regulations	9
Airworthiness Directives	10
Airman's Information Manual	10
Advisory Information	11
FAA Advisory Circulars	11
FAA General Aviation News	15
FAA Accident Prevention Program	15
Additional Information	16
General Information on Specific Topics	17
Maintenance	17
Hazards of Unapproved Modifications	19
Flight Planning	20
Passenger Information Cards	20
Stowage of Articles	21
Flight Operations	21
General	21
Preflight Inspection	21
Weight and Balance	22
Autopilots and Electric Trim Systems	23
Flutter	26
Turbulent Weather	28
Wind Shear	30
Flight in Icing Conditions	31
Weather Radar	36
Mountain Flying	39
VFR - Low Ceilings	39

SECTION X
SAFETY INFORMATION
TABLE OF CONTENTS (Continued)

<i>SUBJECT</i>	<i>PAGE</i>
VFR at Night	40
Vertigo - Disorientation	40
Flight of Multi-Engine Airplanes With One Engine Inoperative	42
Air Minimum Control Speed (V_{MCA})	44
Intentional One-Engine Inoperative Speed (V_{SSE})	45
One-Engine-Inoperative Best Rate-of-Climb Speed (V_{YSE})	45
One-Engine-Inoperative Best Angle-of-Climb Speed (V_{XSE})	46
Single Engine Service Ceiling	46
Basic Single Engine Procedures	46
Engine Failure on Takeoff	47
When to Fly V_X , V_Y , V_{XSE} and V_{YSE}	48
Stalls, Slow Flight and Training	48
Spins	51
Descent	53
Vortices - Wake Turbulence	54
Takeoff and Landing Conditions	55
Medical Facts for Pilots	55
General	55
Fatigue	56
Hypoxia	56
Hyperventilation	58
Alcohol	59
Drugs	60
Scuba Diving	61
Carbon Monoxide and Night Vision	61
Decompression Sickness	61
A Final Word	63

INTRODUCTION

Beech Aircraft Corporation has developed this special summary publication of safety information to refresh pilots' and owners' knowledge of safety related subjects. Topics in this publication are dealt with in more detail in FAA Advisory Circulars and other publications pertaining to the subject of safe flying.

The skilled pilot recognizes that safety consciousness is an integral - and never-ending - part of his or her job. Be thoroughly familiar with your airplane. Know its limitations and your own. Maintain your currency, or fly with a qualified instructor until you are current and proficient. Practice emergency procedures at safe altitudes and airspeeds, preferably with a qualified instructor pilot, until the required action can be accomplished without reference to the manual. Periodically review this Safety Information as part of your recurring training regimen.

BEEHCRAFT airplanes are designed and built to provide you with many years of safe and efficient transportation. By maintaining your BEEHCRAFT properly and flying it prudently you will realize its full potential.

..... Beech Aircraft Corporation

WARNING

Because your airplane is a high performance, high speed transportation vehicle, designed for operation in a three-dimensional environment, special safety precautions must be observed to reduce the risk of fatal or serious injuries to the pilot(s) and occupant(s).

It is mandatory that you fully understand the contents of this publication and the other operating and maintenance manuals which accompany the airplane; that FAA requirements for ratings, certifications and review be scrupulously complied with; and that you allow only persons who are properly licensed and rated, and thoroughly familiar with the contents of the Pilot's Operating Handbook and FAA Approved Airplane Flight Manual to operate the airplane.

IMPROPER OPERATION OR MAINTENANCE OF AN AIRPLANE, NO MATTER HOW WELL BUILT INITIALLY, CAN RESULT IN CONSIDERABLE DAMAGE OR TOTAL DESTRUCTION OF THE AIRPLANE, ALONG WITH SERIOUS OR FATAL INJURIES TO ALL OCCUPANTS.

GENERAL

As a pilot, you are responsible to yourself and to those who fly with you, to other pilots and their passengers and to people on the ground, to fly wisely and safely.

The following material in this Safety Information publication covers several subjects in limited detail. Here are some condensed Do's and Don'ts.

DO'S

Be thoroughly familiar with your airplane, know its limitations and your own.

Be current in your airplane, or fly with a qualified instructor until you are current. Practice until you are proficient.

Preplan all aspects of your flight - including a proper weather briefing and adequate fuel reserves.

Use services available - weather briefing, inflight weather and Flight Service Station.

Carefully preflight your airplane.

Use the approved checklist.

Have more than enough fuel for takeoff, plus the trip, and an adequate reserve.

Be sure your weight loading and C.G. are within limits.

Use seatbelts and shoulder harnesses at all times.

Be sure all loose articles and baggage are secured.

Check freedom and proper direction of operation of all controls during preflight.

Maintain the prescribed airspeeds in takeoff, climb, descent, and landing.

Avoid wake turbulence (Vortices).

Preplan fuel and fuel tank management before the actual flight. Utilize auxiliary tanks only in level cruise flight. Take off and land on the fullest main tank, **NEVER** use auxiliary fuel tanks for take off or landing.

Practice emergency procedures at safe altitudes and air-speeds, preferably with a qualified instructor pilot, until the required action is instinctive.

Keep your airplane in good mechanical condition.

Stay informed and alert; fly in a sensible manner.

DON'TS

Don't take off with frost, ice or snow on the airplane.

Don't take off with less than minimum recommended fuel, plus adequate reserves, and don't run the tank dry before switching.

Don't fly in a reckless, show-off, or careless manner.

Don't fly into thunderstorms or severe weather.

Don't fly in possible icing conditions unless the airplane is approved, properly equipped, and all required equipment is operational for flight in icing conditions.

Don't fly close to mountainous terrain.

Don't apply controls abruptly or with high forces that could exceed design loads of the airplane.

Don't fly into weather conditions that are beyond your ratings or current proficiency.

Don't fly when physically or mentally exhausted or below par.

Don't trust to luck.

SOURCES OF INFORMATION

There is a wealth of information available to the pilot created for the sole purpose of making your flying safer, easier and more efficient. Take advantage of this knowledge and be prepared for an emergency in the event that one should occur.

PILOT'S OPERATING HANDBOOK AND FAA APPROVED AIRPLANE FLIGHT MANUAL

You must be thoroughly familiar with the contents of your operating manuals, placards, and check lists to ensure safe utilization of your airplane. When the airplane was manufactured, it was equipped with one or more of the following: placards, Owner's Manual, FAA Flight Manual, Approved Airplane Flight Manual Supplements, Pilot's Operating Handbook and FAA Approved Airplane Flight Manual. Beech has revised and reissued many of the early manuals for certain models of airplanes in GAMA Standard Format as Pilot's Operating Handbooks and FAA Approved Airplane Flight Manuals. For simplicity and convenience, all official manuals in various models are referred to as the Pilot's Operating Handbook and FAA Approved Airplane Flight Manual. If the airplane has changed ownership, the Pilot's Operating Handbook and FAA Approved Airplane Flight Manual may have been misplaced or may not be current. Replacement handbooks may be obtained from any BEECHCRAFT Authorized Outlet.

BEECHCRAFT SERVICE PUBLICATIONS

Beech Aircraft Corporation publishes a wide variety of manuals, service letters, service instructions, service bulletins, safety communiques and other publications for the various models of BEECHCRAFT airplanes. Information on how

Section X
Safety Information

Beechcraft
Twin Engine (Piston)

to obtain publications relating to your airplane is contained in BEECHCRAFT Service Bulletin number 2001, entitled "General - BEECHCRAFT Service Publications - What is Available and How to Obtain It."

Beech Aircraft Corporation automatically mails original issues and revisions of BEECHCRAFT Service Bulletins (Mandatory, Recommended and Optional), FAA Approved Airplane Flight Manual Supplements, reissues and revisions of FAA Approved Airplane Flight Manuals, Flight Handbooks, Owners Manuals, Pilot's Operating Manuals and Pilot's Operating Handbooks, and original issues and revisions of BEECHCRAFT Safety Communiques to BEECHCRAFT Owner addresses as listed by the FAA Aircraft Registration Branch List and the BEECHCRAFT International Owner Notification Service List. While this information is distributed by Beech Aircraft Corporation, Beech can not make changes in the name or address furnished by the FAA. The owner must contact the FAA regarding any changes to name or address. Their address is: FAA Aircraft Registration Branch (AAC250) P.O. Box 25082, Oklahoma City, OK 73125, Phone (405) 680-2131.

It is the responsibility of the FAA owner of record to ensure that any mailings from Beech are forwarded to the proper persons. Often the FAA registered owner is a bank or financing company or an individual not in possession of the airplane. Also, when an airplane is sold, there is a lag in processing the change in registration with the FAA. If you are a new owner, contact your BEECHCRAFT Authorized Outlet and ensure your manuals are up to date.

Beech Aircraft Corporation provides a subscription service which provides for direct factory mailing of BEECHCRAFT publications applicable to a specific serial number airplane. Details concerning the fees and ordering information for this owner subscription service are contained in Service Bulletin number 2001.

For owners who choose not to apply for a Publications Revision Subscription Service, Beech provides a free Owner

Notification Service by which owners are notified by post card of BEECHCRAFT manual reissues, revisions and supplements which are being issued applicable to the airplane owned. On receipt of such notification, the owner may obtain the publication through a BEECHCRAFT Authorized Outlet. This notification service is available when requested by the owner. This request may be made by using the owner notification request card furnished with the loose equipment of each airplane at the time of delivery, or by a letter requesting this service, referencing the specific airplane serial number owned. Write to :

Supervisor, Special Services
Dept. 52
Beech Aircraft Corporation
P.O. Box 85
Wichita, Kansas 67201-0085

From time to time Beech Aircraft Corporation issues BEECHCRAFT Safety Communiques dealing with the safe operation of a specific series of airplanes, or airplanes in general. It is recommended that each owner/operator maintain a current file of these publications. Back issues of BEECHCRAFT Safety Communiques may be obtained without charge by sending a request, including airplane model and serial number, to the Supervisor, Special Services, at the address listed above.

Airworthiness Directives (AD's) are not issued by the manufacturer. They are issued and available from the FAA.

FEDERAL AVIATION REGULATIONS

FAR Part 91, General Operating and Flight Rules, is a document of law governing operation of airplanes and the owner's and pilot's responsibilities. Some of the subjects covered are:

Responsibilities and authority of the pilot-in-command

Section X Safety Information

Beechcraft Twin Engine (Piston)

Certificates required

Liquor and Drugs

Flight plans

Preflight action

Fuel requirements

Flight Rules

Maintenance, preventive maintenance, alterations, inspection and maintenance records

You, as a pilot, have responsibilities under government regulations. The regulations are designed for your protection and the protection of your passengers and the public. Compliance is mandatory.

AIRWORTHINESS DIRECTIVES

FAR Part 39 specifies that no person may operate a product to which an Airworthiness Directive issued by the FAA applies, except in accordance with the requirements of that Airworthiness Directive.

AIRMAN'S INFORMATION MANUAL

The Airman's Information Manual (AIM) is designed to provide airmen with basic flight information and ATC procedures for use in the national airspace system of the United States. It also contains items of interest to pilots concerning health and medical facts, factors affecting flight safety, a pilot/controller glossary of terms in the Air Traffic Control system, information on safety, and accident/hazard reporting. It is revised at six-month intervals and can be purchased from the Superintendent of Documents, U.S. Government Printing Office, Washington, D.C. 20402.

This document contains a wealth of pilot information. Among the subjects are:

Controlled Airspace

Emergency Procedures
Services Available to Pilots
Weather and Icing
Radio Phraseology and Technique
Mountain Flying
Airport Operations
Wake Turbulence - Vortices
Clearances and Separations
Medical Facts for Pilots
Preflight
Bird Hazards
Departures - IFR
Good Operating Practices
Enroute - IFR
Airport Location Directory
Arrival - IFR

All pilots must be thoroughly familiar with and use the information in the AIM.

ADVISORY INFORMATION

NOTAMS (Notices to Airmen) are documents that have information of a time-critical nature that would affect a pilot's decision to make a flight; for example, an airport closed, terminal radar out of service, or enroute navigational aids out of service.

FAA ADVISORY CIRCULARS

The FAA issues Advisory Circulars to inform the aviation public in a systematic way of nonregulatory material of interest. Advisory Circulars contain a wealth of information with which the prudent pilot should be familiar. A complete list of current FAA Advisory Circulars is published in AC 00-2, which lists Advisory Circulars that are for sale, as well as those distributed free of charge by the FAA, and provides

Section X
Safety Information

Beechcraft
Twin Engine (Piston)

ordering information. Many Advisory Circulars which are for sale can be purchased locally in aviation bookstores or at FBO's. These documents are subject to periodic revision. Be certain the Advisory Circular you are using is the latest revision available. Some of the Advisory Circulars of interest to pilots are:

- | | |
|---------------|--|
| *00-6 | Aviation Weather |
| 00-24 | Thunderstorms |
| 00-30 | Rules of Thumb for Avoiding or Minimizing Encounters with Clear Air Turbulence |
| *00-45 | Aviation Weather Services |
| 00-46 | Aviation Safety Reporting Program |
| 20-5 | Plane Sense |
| 20-32 | Carbon Monoxide (CO) Contamination in Aircraft - Detection and Prevention |
| 20-35 | Tie-Down Sense |
| 20-43 | Aircraft Fuel Control |
| 20-105 | Engine-Power Loss Accident Prevention |
| 20-113 | Pilot Precautions and Procedures to be Taken in Preventing Aircraft Reciprocating Engine Induction System and Fuel System Icing Problems |
| 20-125 | Water in Aviation Fuels |
| 21-4 | Special Flight Permits for Operation of Overweight Aircraft |
| 43-9 | Maintenance Records: General Aviation Aircraft |

43-12	Preventive Maintenance
60-4	Pilot's Spatial Disorientation
60-6	Airplane Flight Manuals (AFM), Approved Manual Materials, Markings and Placards - Airplanes
60-12	Availability of Industry-Developed Guidelines for the Conduct of the Bien- nial Flight Review
60-13	The Accident Prevention Counselor Program
*61-9	Pilot Transition Courses for Complex Single-Engine and Light Twin-Engine Airplanes
*61-21	Flight Training Handbook
*61-23	Pilot's Handbook of Aeronautical Knowledge
*61-27	Instrument Flying Handbook
61-67	Hazards Associated with Spins in Air- planes Prohibited from Intentional Spinning.
61-84	Role of Preflight Preparation
*67-2	Medical Handbook for Pilots
90-23	Aircraft Wake Turbulence
90-42	Traffic Advisory Practices at Nontower Airports
90-48	Pilot's Role in Collision Avoidance
90-66	Recommended Standard Traffic Pat- terns for Airplane Operations at Uncontrolled Airports

**Section X
Safety Information**

**Beechcraft
Twin Engine (Piston)**

- | | |
|---------------|--|
| 90-85 | Severe Weather Avoidance Plan (SWAP) |
| 91-6 | Water, Slush and Snow on the Runway |
| 91-13 | Cold Weather Operation of Aircraft |
| *91-23 | Pilot's Weight and Balance Handbook |
| 91-26 | Maintenance and Handling of Air Driven Gyroscopic Instruments |
| 91-33 | Use of Alternate Grades of Aviation Gasoline for Grade 80/87 |
| 91-35 | Noise, Hearing Damage, and Fatigue in General Aviation Pilots |
| 91-43 | Unreliable Airspeed Indications |
| 91-44 | Operational and Maintenance Practices for Emergency Locator Transmitters and Receivers |
| 91-46 | Gyroscopic Instruments - Good Operating Practices |
| 91-50 | Importance of Transponder Operations and Altitude Reporting |
| 91-51 | Airplane Deice and Anti-ice Systems |
| 91-59 | Inspection and Care of General Aviation Aircraft Exhaust Systems |
| 91-65 | Use of Shoulder Harness in Passenger Seats |
| 103-4 | Hazards Associated with Sublimation of Solid Carbon Dioxide (Dry Ice) Aboard Aircraft |
| 135-9 | FAR Part 135 Icing Limitations |

210-5A Military Flying Activities

*** For Sale**

FAA GENERAL AVIATION NEWS

FAA General Aviation News is published by the FAA in the interest of flight safety. The magazine is designed to promote safety in the air by calling the attention of general aviation airmen to current technical, regulatory and procedural matters affecting the safe operation of airplanes. FAA General Aviation News is sold on subscription by the Superintendent of Documents, Government Printing Office, Washington D.C., 20402.

FAA ACCIDENT PREVENTION PROGRAM

The FAA assigns accident prevention specialists to each Flight Standards and General Aviation District Office to organize accident prevention program activities. In addition, there are over 3,000 volunteer airmen serving as accident prevention counselors, sharing their technical expertise and professional knowledge with the general aviation community. The FAA conducts seminars and workshops, and distributes invaluable safety information under this program.

Usually the airport manager, the FAA Flight Service Station (FSS), or Fixed Base Operator (FBO), will have a list of accident prevention counselors and their phone numbers available. All Flight Standards and General Aviation District Offices have a list of the counselors serving the District.

Before flying over unfamiliar territory, such as mountainous terrain or desert areas, it is advisable for transient pilots to consult with local counselors. They will be familiar with the more desirable routes, the wind and weather conditions, and the service and emergency landing areas that are available along the way. They can also offer advice on the type of emergency equipment you should be carrying.

ADDITIONAL INFORMATION

The National Transportation Safety Board and the Federal Aviation Administration periodically issue, in greater detail, general aviation pamphlets concerning aviation safety. FAA Regional Offices also publish material under the FAA General Aviation Accident Prevention Program. These can be obtained at FAA Offices, Weather Stations, Flight Service Stations or Airport Facilities. Some of these are titled:

12 Golden Rules for Pilots
Weather or Not
Disorientation
Plane Sense
Weather Info Guide for Pilots
Wake Turbulence
Don't Trust to Luck, Trust to Safety
Rain, Fog, Snow
Thunderstorm - TRW
Icing
Pilot's Weather Briefing Guide
Thunderstorms Don't Flirt ... Skirt 'em
IFR-VFR - Either Way Disorientation Can Be Fatal
IFR Pilot Exam-O-Grams
VFR Pilot Exam-O-Grams
Flying Light Twins Safely
Tips on Engine Operation in Small General Aviation Aircraft
Estimating Inflight Visibility
Is the Aircraft Ready for Flight
Tips on Mountain Flying
Tips on Desert Flying
Always Leave Yourself An Out
Safety Guide for Private Aircraft Owners
Tips on How to Use the Flight Planner
Tips on the Use of Ailerons and Rudder
Some Hard Facts About Soft Landings

Propeller Operation and Care

Torque "What it Means to the Pilot"

Weight and Balance. An Important Safety Consideration for Pilots

GENERAL INFORMATION ON SPECIFIC TOPICS

MAINTENANCE

Safety of flight begins with a well maintained airplane. Make it a habit to keep your airplane and all of its equipment in airworthy condition. Keep a "squawk list" on board, and see that all discrepancies, however minor, are noted and promptly corrected.

Schedule your maintenance regularly, and have your airplane serviced by a reputable organization. Be suspicious of bargain prices for maintenance, repair and inspections.

It is the responsibility of the owner and the operator to assure that the airplane is maintained in an airworthy condition and that proper maintenance records are kept.

Use only genuine BEECHCRAFT or BEECHCRAFT approved parts obtained from BEECHCRAFT approved sources, in connection with the maintenance and repair of Beech airplanes.

Genuine BEECHCRAFT parts are produced and inspected under rigorous procedures to insure airworthiness and suitability for use in Beech airplane applications. Parts purchased from sources other than BEECHCRAFT, even though outwardly identical in appearance, may not have had the required tests and inspections performed, may be different in fabrication techniques and materials, and may be dangerous when installed in an airplane.

Salvaged airplane parts, reworked parts obtained from non-BEECHCRAFT approved sources or parts, components, or structural assemblies, the service history of which is unknown or cannot be authenticated, may have been subjected to unacceptable stresses or temperatures or have other hidden damage not discernible through routine visual or usual nondestructive testing techniques. This may render the part, component or structural assembly, even though originally manufactured by BEECHCRAFT, unsuitable and unsafe for airplane use.

BEECHCRAFT expressly disclaims any responsibility for malfunctions, failures, damage or injury caused by use of non-BEECHCRAFT parts.

Airplanes operated for Air Taxi or other than normal operation, and airplanes operated in humid tropics, or cold and damp climates, etc., may need more frequent inspections for wear, corrosion and/or lack of lubrication. In these areas, periodic inspections should be performed until the operator can set his own inspection periods based on experience.

NOTE

The required periods do not constitute a guarantee that the item will reach the period without malfunction, as the aforementioned factors cannot be controlled by the manufacturer.

Corrosion and its effects must be treated at the earliest possible opportunity. A clean, dry surface is virtually immune to corrosion. Make sure that all drain holes remain unobstructed. Protective films and sealants help to keep corrosive agents from contacting metallic surfaces. Corrosion inspections should be made most frequently under high-corrosion-risk operating conditions, such as in areas of

excessive airborne salt concentrations (e.g., near the sea) and in high-humidity areas (e.g., tropical regions).

If you have purchased a used airplane, have your mechanic inspect the airplane registration records, logbooks and maintenance records carefully. An unexplained period of time for which the airplane has been out of service, or unexplained significant repairs may well indicate the airplane has been seriously damaged in a prior accident. Have your mechanics inspect a used airplane carefully. Take the time to ensure that you really know what you are buying when you buy a used airplane.

HAZARDS OF UNAPPROVED MODIFICATIONS

Many airplane modifications are approved under Supplemental Type Certificates (STC's). Before installing an STC on your airplane, check to make sure that the STC does not conflict with other STC's that have already been installed. Because approval of an STC is obtained by the individual STC holder based upon modification of the original type design, it is possible for STC's to interfere with each other when both are installed. Never install an unapproved modification of any type, however innocent the apparent modification may seem. Always obtain proper FAA approval.

Airplane owners and maintenance personnel are particularly cautioned not to make attachments to, or otherwise modify, seats from original certification without approval from the FAA Engineering and Manufacturing District Office having original certification responsibility for that make and model.

Any unapproved attachment or modification to seat structure may increase load factors and metal stress which could cause failure of seat structure at a lesser "G" force than exhibited for original certification.

Examples of unauthorized attachments found are drilling holes in seat tubing to attach fire extinguishers and drilling holes to attach approach plate book bins to seats.

FLIGHT PLANNING

FAR Part 91 requires that each pilot in command, before beginning a flight, familiarize himself with all available information concerning that flight.

Obtain a current and complete preflight briefing. This should consist of local, enroute and destination weather and enroute navaid information. Enroute terrain and obstructions, alternate airports, airport runways active, length of runways, and takeoff and landing distances for the airplane for conditions expected should be known.

The prudent pilot will review his planned enroute track and stations and make a list for quick reference. It is strongly recommended a flight plan be filed with Flight Service Stations, even though the flight may be VFR. Also, advise Flight Service Stations of changes or delays of one hour or more and remember to close the flight plan at destination.

The pilot must be completely familiar with the performance of the airplane and performance data in the Pilot's Operating Handbook and FAA Approved Airplane Flight Manual. The resultant effect of temperature and pressure altitude must be taken into account in performance if not accounted for on the charts. An applicable FAA Approved Airplane Flight Manual must be aboard the airplane at all times and include the weight and balance forms and equipment list.

PASSENGER INFORMATION CARDS

Beech has available, for most current production airplanes, passenger information cards which contain important information on the proper use of restraint systems, oxygen

masks, emergency exits and emergency bracing procedures. Passenger information cards may be obtained at any BEECHCRAFT Authorized Outlet. A pilot should not only be familiar with the information contained in the cards, but should always, prior to flight, inform the passengers of the information contained in the information cards. The pilot should orally brief the passengers on the proper use of restraint systems, doors and emergency exits, and other emergency procedures, as required by Part 91 of the FAR's.

STOWAGE OF ARTICLES

The space between the seat pan and the floor is utilized to provide space for seat displacement. If hard, solid objects are stored beneath seats, the energy absorbing feature is lost and severe spinal injuries can occur to occupants.

Prior to flight, pilots should insure that articles are not stowed beneath seats that would restrict seat pan energy absorption or penetrate the seat in event of a high vertical velocity accident.

FLIGHT OPERATIONS

GENERAL

The pilot **MUST** be thoroughly familiar with ALL INFORMATION published by the manufacturer concerning the airplane, and is required by law to operate the airplane in accordance with the FAA Approved Airplane Flight Manual and placards installed.

PREFLIGHT INSPECTION

In addition to maintenance inspections and preflight information required by FAR Part 91, a complete, careful preflight inspection is imperative.

Each airplane has a checklist for the preflight inspection which must be followed. USE THE CHECKLIST.

WEIGHT AND BALANCE

Maintaining center of gravity within the approved envelope throughout the planned flight is an important safety consideration.

The airplane must be loaded so as not to exceed the weight and center of gravity (C.G.) limitations. Airplanes that are loaded above the maximum takeoff or landing weight limitations will have an overall lower level of performance compared to that shown in the Performance section of the Pilot's Operating Handbook and FAA Approved Airplane Flight Manual. If loaded above maximum takeoff weight, takeoff distance and the landing distance will be longer than that shown in the Performance section; the stalling speed will be higher, rate of climb, the cruising speed, and the range of the airplane at any level of fuel will all be lower than shown in the Performance section.

If an airplane is loaded so that the C.G. is forward of the forward limit it will require additional control movements for maneuvering the airplane with correspondingly higher control forces. The pilot may have difficulty during takeoff and landing because of the elevator control limits.

If an airplane is loaded aft of the aft C.G. limitation, the pilot will experience a lower level of stability. Airplane characteristics that indicate a lower stability level are; lower control forces, difficulty in trimming the airplane, lower control forces for maneuvering with attendant danger of structural overload, decayed stall characteristics, and a lower level of lateral-directional damping.

Ensure that all cargo and baggage is properly secured before takeoff. A sudden shift in balance at rotation can cause controllability problems.

AUTOPILOTS AND ELECTRIC TRIM SYSTEMS

Because there are several different models of autopilots and electric trim systems installed in Beech airplanes and different installations and switch positions are possible from airplane to airplane, it is essential that every owner/operator review his Airplane Flight Manual (AFM) Supplements and ensure that the supplements properly describe the autopilot and trim installations on his specific airplane. Each pilot, prior to flight, must be fully aware of the proper procedures for operation, and particularly disengagement, for the system as installed.

In addition to ensuring compliance with the autopilot manufacturer's maintenance requirements, all owners/operators should thoroughly familiarize themselves with the operation, function and procedures described in the Airplane Flight Manual Supplements. Ensure a full understanding of the methods of engagement and disengagement of the autopilot and trim systems.

Compare the descriptions and procedures contained in the Supplements to the actual installation in the airplane to ensure that the supplement accurately describes your installation. Test that all buttons, switches and circuit breakers function as described in the Supplements. If they do not function as described, have the system repaired by a qualified service agency. If field service advice or assistance is necessary, contact Beech Aircraft Corporation, Customer Support Department.

As stated in all AFM Supplements for autopilot systems and trim systems installed on Beech airplanes, the preflight check must be conducted before every flight. The preflight check assures not only that the systems and all of their features are operating properly, but also that the pilot, before flight, is familiar with the proper means of engagement and disengagement of the autopilot and trim system.

Autopilot Airplane Flight Manual Supplements caution against trying to override the autopilot system during flight without disengaging the autopilot because the autopilot will continue to trim the airplane and oppose the pilot's actions. This could result in a severely out of trim condition. This is a basic feature of all autopilots with electric trim follow-up.

Do not try to manually override the autopilot during flight.

IN CASE OF EMERGENCY, YOU CAN OVERPOWER THE AUTOPILOT TO CORRECT THE ATTITUDE, BUT THE AUTOPILOT AND ELECTRIC TRIM MUST THEN IMMEDIATELY BE DISENGAGED.

It is often difficult to distinguish an autopilot malfunction from an electric trim system malfunction. The safest course is to deactivate both. Do not re-engage either system until after you have safely landed. Then have the systems checked by a qualified service facility prior to further flight.

Depending upon the installation on your airplane, the following additional methods may be available to disengage the autopilot or electric trim in the event that the autopilot or electric trim does not disengage utilizing the disengage methods specified in the Supplements.

CAUTION

Transient control forces may occur when the autopilot is disengaged.

1. Turn off the autopilot master switch, if installed.
2. Pull the autopilot and trim circuit breaker(s) or turn off the autopilot switch breaker, if installed.
3. Turn off the RADIO MASTER SWITCH, if installed, and

if the autopilot system and the trim system are wired through this switch.

CAUTION

Radios, including VHF COMM are also disconnected when the radio master switch is off.

4. Turn off the ELECTRIC MASTER SWITCH.

WARNING

Most electrically powered systems will be inoperative. Consult the AFM for further information.

5. Push the GA switch on throttle grip, if installed (depending upon the autopilot system).
6. Push TEST EACH FLT switch on the autopilot controller, if installed.

NOTE

After the autopilot is positively disengaged, it may be necessary to restore other electrical functions. Be sure when the master switches are turned on that the autopilot does not re-engage.

The above ways may or may not be available on your autopilot. It is essential that you read your airplane's AFM

SUPPLEMENT for your autopilot system and check each function and operation on your system.

The engagement of the autopilot must be done in accordance with the instructions and procedures contained in the AFM SUPPLEMENT.

Particular attention must be paid to the autopilot settings prior to engagement. If you attempt to engage the autopilot when the airplane is out of trim, a large attitude change may occur.

IT IS ESSENTIAL THAT THE PROCEDURES SET FORTH IN THE APPROVED AFM SUPPLEMENTS FOR YOUR SPECIFIC INSTALLATION BE FOLLOWED BEFORE ENGAGING THE AUTOPILOT.

FLUTTER

Flutter is a phenomenon that can occur when an aerodynamic surface begins vibrating. The energy to sustain the vibration is derived from airflow over the surface. The amplitude of the vibration can (1) decrease, if airspeed is reduced; (2) remain constant, if airspeed is held constant and no failures occur; or (3) increase to the point of self-destruction, especially if airspeed is high and/or is allowed to increase. Flutter can lead to an in-flight break up of the airplane. Airplanes are designed so that flutter will not occur in the normal operating envelope of the airplane as long as the airplane is properly maintained. In the case of any airplane, decreasing the damping and stiffness of the structure or increasing the trailing edge weight of control surfaces will tend to cause flutter. If a combination of those factors is sufficient, flutter can occur within the normal operating envelope.

Owners and operators of airplanes have the primary responsibility for maintaining their airplanes. To fulfill that responsibility, it is imperative that all airplanes receive a thorough

preflight inspection. Improper tension on the control cables or any other loose condition in the flight control system can also cause or contribute to flutter. Pilots should pay particular attention to control surface attachment hardware including tab pushrod attachment during preflight inspection. Looseness of fixed surfaces or movement of control surfaces other than in the normal direction of travel should be rectified before flight. Further, owners should take their airplanes to mechanics who have access to current technical publications and prior experience in properly maintaining that make and model of airplane. The owner should make certain that control cable tension inspections are performed as outlined in the applicable Beech Inspection Guide. Worn control surface attachment hardware must be replaced. Any repainting or repair of a moveable control surface will require a verification of the control surface balance before the airplane is returned to service. Control surface drain holes must be open to prevent freezing of accumulated moisture, which could create an increased trailing-edge-heavy control surface and flutter.

If an excessive vibration, particularly in the control column and rudder pedals, is encountered in flight, this may be the onset of flutter and the procedure to follow is:

1. IMMEDIATELY REDUCE AIRSPEED (lower the landing gear, if necessary).
2. RESTRAIN THE CONTROLS OF THE AIRPLANE UNTIL THE VIBRATION CEASES.
3. FLY AT THE REDUCED AIRSPEED AND LAND AT THE NEAREST SUITABLE AIRPORT.
4. HAVE THE AIRPLANE INSPECTED FOR AIRFRAME DAMAGE, CONTROL SURFACE ATTACHING HARDWARE CONDITION/SECURITY, TRIM TAB FREE PLAY, PROPER CONTROL CABLE TENSION, AND CONTROL SURFACE BALANCE BY ANOTHER MECHANIC WHO IS FULLY QUALIFIED.

TURBULENT WEATHER

A complete and current weather briefing is a requirement for a safe trip.

Updating of weather information en route is also essential. The wise pilot knows that weather conditions can change quickly, and treats weather forecasting as professional advice, rather than an absolute fact. He obtains all the advice he can, but stays alert to any sign or report of changing conditions.

Plan the flight to avoid areas of reported severe turbulence. It is not always possible to detect individual storm areas or find the in-between clear areas.

The National Weather Service classifies turbulence as follows:

Class of Turbulence	Effect
Extreme	Airplane is violently tossed about and is practically impossible to control. May cause structural damage.
Severe	Airplane may be momentarily out of control. Occupants are thrown violently against the belts and back into the seat. Unsecured objects are tossed about.
Moderate	Occupants require seat belts and occasionally are thrown against the belt. Unsecured objects move about.

Light Occupants may be required to use seat belts, but objects in the airplane remain at rest.

Thunderstorms, squall lines and violent turbulence should be regarded as extremely dangerous and must be avoided. Hail and tornadic wind velocities can be encountered in thunderstorms that can destroy any airplane, just as tornadoes destroy nearly everything in their path on the ground.

Thunderstorms also pose the possibility of a lightning strike on an airplane. Any structure or equipment which shows evidence of a lightning strike, or of being subjected to a high current flow due to a strike, or is a suspected part of a lightning strike path through the airplane should be thoroughly inspected and any damage repaired prior to additional flight.

A roll cloud ahead of a squall line or thunderstorm is visible evidence of extreme turbulence; however, the absence of a roll cloud should not be interpreted as denoting that severe turbulence is not present.

Even though flight in severe turbulence must be avoided, flight in turbulent air may be encountered unexpectedly under certain conditions.

The following recommendations should be observed for airplane operation in turbulent air:

Flying through turbulent air presents two basic problems, the answer to both of which is proper airspeed. On one hand, if you maintain an excessive airspeed, you run the risk of structural damage or failure; on the other hand, if your airspeed is too low, you may stall.

If turbulence is encountered, reduce speed to the turbulent air penetration speed, if given, or to the maneuvering speed, which is listed in the Limitations section of the Pilot's Operating Handbook and FAA Approved Airplane Flight Manual.

These speeds give the best assurance of avoiding excessive stress loads, and at the same time provide the proper margin against inadvertent stalls due to gusts.

Beware of overcontrolling in an attempt to correct for changes in attitude; applying control pressure abruptly will build up G-forces rapidly and could cause structural damage or even failure. You should watch particularly your angle of bank, making turns as wide and shallow as possible. Be equally cautious in applying forward or back pressure to keep the airplane level. Maintain straight and level attitude in either up or down drafts. Use trim sparingly to avoid being grossly out of trim as the vertical air columns change velocity and direction. If necessary to avoid excessive airspeeds, lower the landing gear.

WIND SHEAR

Wind shears are rapid, localized changes in wind direction, which can occur vertically as well as horizontally. Wind shear can be very dangerous to all airplanes, large and small, particularly on approach to landing when airspeeds are slow.

A horizontal wind shear is a sudden change in wind direction or speed that can, for example, transform a headwind into a tailwind, producing a sudden decrease in indicated airspeed because of the inertia of the airplane. A vertical wind shear, is a sudden updraft or downdraft. Microbursts are intense, highly localized severe downdrafts.

The prediction of wind shears is far from an exact science. Monitor your airspeed carefully when flying near storms, particularly on approach. Be mentally prepared to add power and go around at the first indication that a wind shear is being encountered.

FLIGHT IN ICING CONDITIONS

Every pilot should be intimately acquainted with the FAA Approved National Weather Service definitions for ice intensity and accumulation which we have reprinted below:

Intensity	Ice Accumulation
Trace	Ice becomes perceptible. Rate of accumulation slightly greater than rate of sublimation. It is not hazardous even though deicing/anti-icing equipment is not utilized, unless encountered for an extended period of time (over 1 hour).
Light	The rate of accumulation may create a problem if flight is prolonged in this environment (over 1 hour). Occasional use of deicing/anti-icing equipment removes/prevents accumulation. It does not present a problem if the deicing/anti-icing equipment is used.
Moderate	The rate of accumulation is such that even short encounters become potentially hazardous and use of deicing/anti-icing equipment or diversion is necessary.
Severe	The rate of accumulation is such that deicing/anti-icing equipment fails to reduce or control the hazard. Immediate diversion is necessary.

It is no longer unusual to find deicing and anti-icing equipment on a wide range of airplane sizes and types. Since the capability of this equipment varies, it becomes the pilot's primary responsibility to understand limitations which restrict the use of his airplane in icing conditions and the conditions which may exceed the systems capacity.

Pilots and airplane owners must carefully review the Pilot's Operating Handbook and FAA Approved Airplane Flight Manual in order to ascertain the required operable equipment needed for flight in icing conditions. In addition, they must ascertain from the same source the limits of approval or certification of their airplane for flight in icing conditions, and plan the flight accordingly, if icing conditions are known or forecast along the route.

Every owner and pilot of an airplane should understand that it is not uncommon to find airplanes equipped with less than the full complement of available systems and equipment. For example, propellers and pitot tube may be protected, but the airplane may not have wing boots or tail boots. The reverse might be true. Windshield, pitot and airfoil surfaces might be protected, but the propellers might not be. Before undertaking any flight into areas where icing conditions might be expected, inspect the airplane and review the Pilot's Operating Handbook and FAA Approved Airplane Flight Manual to be certain that you are supported by the full complement of required IFR and deicing/anti-icing equipment.

Remember that regardless of its combination of deicing/anti-icing equipment, any airplane not fully equipped and functional for IFR flight is not properly equipped for flight in icing conditions. An airplane which is not approved or certificated for flight in icing conditions, or which does not have all critical areas protected in the required manner by fully operational anti-icing equipment must not be exposed to icing encounters of any intensity. When icing is detected, the pilot of such an airplane must make an immediate diversion by flying out of the area of visible moisture or going to an altitude where icing is not encountered.

Some models of Beech airplanes were approved for flight in certain limited icing conditions under the FAA's Bureau of Flight Standards Release No. 434. Under this release, properly equipped airplanes are approved for flight in light to

moderate icing conditions only. Refer to Sections 2 and 4 of the above document for icing limitations. These airplanes are not approved for extended flight in moderate icing conditions or flights in any severe icing conditions. Flight in these conditions must be avoided.

Even airplanes fully equipped and certified for flight in the icing conditions described in Appendix C to FAR Part 25 must avoid flights into those conditions defined by the National Weather Service as "Severe". The National Weather Service definition of "Severe Icing" describes that conditions as: "the rate of accumulation is such that deicing/anti-icing equipment fails to reduce or control the hazard." No airplane equipped with any combination of deicing/anti-icing equipment can be expected to cope with such conditions. As competent pilots know, there appears to be no predictable limits for the severest weather conditions. For essentially the same reasons that airplanes, however designed or equipped for IFR flight, cannot be flown safely into conditions such as thunderstorms, tornadoes, hurricanes or other phenomena likely to produce severe turbulence, airplanes equipped for flight in icing conditions cannot be expected to cope with "Severe" icing conditions as defined by the National Weather Service. The prudent pilot must remain alert to the possibility that icing conditions may become "severe" and that his equipment will not cope with them. At the first indication that such condition may have been encountered or may lie ahead, he should immediately react by selecting the most expeditious and safe course for diversion.

Every pilot of a properly fully-equipped Beech airplane who ventures into icing conditions must maintain the minimum speed (KIAS) for operation in icing conditions, which is set forth in the Normal Procedures section, and in the Limitations section, of his Pilot's Operating Handbook and FAA Approved Airplane Flight Manual. If a minimum speed for flight in icing conditions is not specified in the manual, the following minimum indicated airspeeds must be maintained:

Section X
Safety Information

Beechcraft
Twin Engine (Piston)

All Baron and Travel Air Models - 130 KIAS

All other BEECHCRAFT twin-engine models - 140 KIAS

The pilot must remain aware of the fact that if he allows his airspeed to deteriorate below this minimum speed, he will increase the angle of attack of his airplane to the point where ice may build up on the under side of the wings aft of the area protected by the boots.

The fact or extent of ice build-up in unprotected areas will not be directly observable from the cockpit. Due to distortion of the wing airfoil, increased drag and reduced lift, stalling speeds will increase as ice accumulates on the airplane. For the same reasons, stall warning devices are not accurate and cannot be relied upon in icing conditions.

Even though the pilot maintains the prescribed minimum speeds for operating in icing conditions, ice is still likely to build up on the unprotected areas (the fuselage and unprotected wing leading edge inboard of the engine nacelle). Under some atmospheric conditions, it may even build up aft of the boots despite the maintenance of the prescribed minimum speed. The effect of ice accumulation on any unprotected surface is aggravated by length of exposure to the icing conditions. Ice buildup on unprotected surfaces will increase drag, add weight, reduce lift, and generally, adversely affect the aerodynamic characteristics and performance of the airplane. It can progress to the point where the airplane is no longer capable of flying. Therefore, the pilot operating even a fully-equipped airplane in sustained icing conditions must remain sensitive to any indication, such as observed ice accumulation, loss of airspeed, the need for increased power, reduced rate of climb, or sluggish response, that ice is accumulating on unprotected surfaces and that continued flight in these conditions is extremely hazardous, regardless of the performance of the deicing/anti-icing equipment.

Since flight in icing conditions is not an everyday occurrence, it is important that pilots maintain a proper proficiency and awareness of the operating procedures necessary for safe operation of the airplane and that the airplane is in a condition for safe operation.

Ensure moisture drains in the airplane structure are maintained open as specified in the Aircraft Maintenance Manual, so that moisture will not collect and cause freezing in the control cable area. Also, control surface tab hinges should be maintained and lubricated as specified in the Aircraft Maintenance Manual.

In icing conditions the autopilot should be disengaged at an altitude sufficient to permit the pilot to gain the feel of the airplane prior to landing. In no case should this be less than the minimum altitude specified in the Autopilot Airplane Flight Manual Supplement.

Observe the procedures set forth in your Pilot's Operating Handbook and FAA Approved Airplane Flight Manual during operation in icing conditions.

Activate your deice and anti-icing systems before entering an area of moisture where you are likely to go through a freezing level, to make sure all necessary equipment is operative.

Rapid cycling of deice boots or cycling before at least one-half inch (1/2") of ice has accumulated (measured in the chordwise direction or forward from the leading edge), may cause the ice to grow outside the contour of the inflated boots and prevent ice removal.

For any owner or pilot whose use pattern for an airplane exposes it to icing encounters, the following references are required reading for safe flying:

- The airplane's Pilot's Operating Handbook and FAA

Approved Airplane Flight Manual, especially the sections on Normal Procedures, Emergency Procedures, Abnormal Procedures, Systems, and Safety Information.

- FAA Advisory Circulars 91-51 Airplane Deice and Anti-ice Systems
- FAA Advisory Circulars 135-9 - Icing Limitations
- Weather Flying by Robert N. Buck.

Finally, the most important ingredients to safe flight in icing conditions - regardless of the airplane or the combination of deicing/anti-icing equipment - are a complete and current weather briefing, sound pilot judgement, close attention to the rate and type of ice accumulations, and the knowledge that "severe icing" as defined by the National Weather Service is beyond the capability of modern airplanes and immediate diversion must be made. It is the inexperienced or uneducated pilot who presses on "regardless", hoping that steadily worsening conditions will improve, only to find himself flying an airplane which has become so loaded with ice that he can no longer maintain altitude. At this point he has lost most, if not all, of his safety options, including perhaps a 180 degree turn to return along the course already traveled.

The responsible and well-informed pilot recognizes the limitations of weather conditions, his airplane and its systems, and reacts promptly.

WEATHER RADAR

Airborne weather avoidance radar is, as its name implies, for avoiding severe weather--not for penetrating it. Whether to fly into an area of radar echoes depends on echo intensity and shape, spacing between the echoes, and the capabilities of you and your airplane. Remember that weather radar detects only precipitation drops. Therefore, the radar scope provides no assurance of avoiding turbulence. The radar scope also does not provide assurance of avoiding

instrument weather from clouds and fog. Your scope may be clear between intense echoes; this clear area does not necessarily mean you can fly between the storms and maintain visual sighting of them.

Thunderstorms build and dissipate rapidly. Therefore, do not attempt to plan a course between echoes using ground based radar. The best use of ground radar information is to isolate general areas and coverage of echoes. You must avoid individual storms from in-flight observations either by visual sighting or by airborne radar. It is better to avoid the whole thunderstorm area than to detour around individual storms unless they are scattered.

Remember that while hail always gives a radar echo, it may fall several miles from the nearest visible cloud and hazardous turbulence may extend to as much as 20 miles from the echo edge. The intensity of the radar echo from hail varies with the size and nature of the hailstone. A hailstone with a wet surface gives a strong radar return while a dry hailstone gives a relatively weak return. Avoid intense or extreme level echoes by at least 20 miles; that is, such echoes should be separated by at least 40 miles before you fly between them. With weaker echoes you can reduce the distance by which you avoid them.

Above all, remember this: never regard any thunderstorm lightly. Even when radar observers report the echoes are of light intensity, avoiding thunderstorms is the best policy. The following are some do's and don'ts of thunderstorm avoidance:

1. Don't land or take off in the face of an approaching thunderstorm. A sudden gust front of low level turbulence could cause loss of control.
2. Don't attempt to fly under a thunderstorm even if you can see through to the other side. Turbulence and wind shear under the storm could be disastrous.

3. Don't fly without airborne radar into a cloud mass containing scattered embedded thunderstorms. Embedded thunderstorms usually can not be visually circumnavigated.
4. Don't trust visual appearance to be a reliable indicator of the turbulence inside a thunderstorm.
5. Do avoid by at least 20 miles any thunderstorm identified as severe or giving an intense radar echo. This is especially true under the anvil of a large cumulonimbus.
6. Do circumnavigate the entire area if the area has 6/10 or greater thunderstorm coverage.
7. Do remember that vivid and frequent lightning indicates the probability of a severe thunderstorm.
8. Do regard as extremely hazardous any thunderstorm with tops 35,000 feet or higher, whether the top is visually sighted or determined by radar.

If you cannot avoid penetrating a thunderstorm, the following are some do's BEFORE entering the storm:

9. Tighten your safety belt, put on your shoulder harness, and secure all loose objects.
10. Plan and hold your course to take you through the storm in minimum time.
11. To avoid the most critical icing, establish a penetration altitude below the freezing level or above the level of -15°C .
12. Verify that pitot heat is on and turn on carburetor heat or engine anti-ice. Icing can be rapid at any altitude and cause almost instantaneous power failure and/or loss of airspeed indication.

MOUNTAIN FLYING

Pilots flying in mountainous areas should inform themselves of all aspects of mountain flying, including the effects of topographic features on weather conditions. Many good articles have been published, and a synopsis of mountain flying operations is included in the FAA Airman's Information Manual, Part 1.

Avoid flight at low altitudes over mountainous terrain, particularly near the lee slopes. If the wind velocity near the level of the ridge is in excess of 25 knots and approximately perpendicular to the ridge, mountain wave conditions are likely over and near the lee slopes. If the wind velocity at the level of the ridge exceeds 50 knots, a strong mountain wave is probable with extreme up and down drafts and severe turbulence. The worst turbulence will be encountered in and below the rotor zone, which is usually 8 to 10 miles downwind from the ridge. This zone is sometimes characterized by the presence of "roll clouds" if sufficient moisture is present; altocumulus standing lenticular clouds are also visible signs that a mountain wave exists, but their presence is likewise dependent on moisture. Mountain wave turbulence can, of course, occur in dry air and the absence of such clouds should not be taken as assurance that mountain wave turbulence will not be encountered. A mountain wave downdraft may exceed the climb capability of your airplane. Avoid mountain wave downdrafts.

VFR - LOW CEILINGS

If you are not instrument rated, do not attempt "VFR on Top" or "Special VFR" flight or clearances. Being caught above a solid cloud layer when an emergency descent is required (or at destination) is an extremely hazardous position for the VFR pilot. Accepting a clearance out of airport control zones with no minimum ceiling and one-mile visibility as permitted with "Special VFR" is a foolish practice for the VFR pilot.

Avoid areas of low ceilings and restricted visibility unless you are instrument rated and proficient and have an instrument equipped airplane. Then proceed with caution and with planned alternates.

VFR AT NIGHT

When flying VFR at night, in addition to the altitude appropriate for the direction of flight, pilots should maintain a safe minimum altitude as dictated by terrain, obstacles such as TV towers, or communities in the area flown. This is especially true in mountainous terrain, where there is usually very little ground reference. Minimum clearance is 2,000 feet above the highest obstacle en route. Do not depend on your ability to see obstacles in time to miss them. Flight on dark nights over sparsely populated country can be the same as IFR, and must be avoided by inexperienced or non-IFR rated pilots.

VERTIGO - DISORIENTATION

Disorientation can occur in a variety of ways. During flight, inner ear balancing mechanisms are subjected to varied forces not normally experienced on the ground. This, combined with loss of outside visual reference, can cause vertigo. False interpretations (illusions) result, and may confuse the pilot's conception of the attitude and position of his airplane.

Under VFR conditions, the visual sense, using the horizon as a reference, can override the illusions. Under low visibility conditions (night, fog, clouds, haze, etc.) the illusions predominate. Only through awareness of these illusions, and proficiency in instrument flight procedures, can an airplane be operated safely in a low visibility environment.

Flying in fog, dense haze or dust, cloud banks, or very low visibility, with strobe lights or rotating beacons turned on can

contribute to vertigo. They should be turned off in these conditions, particularly at night.

All pilot's should check the weather and use good judgment in planning flights. The VFR pilot should use extra caution in avoiding low visibility conditions.

Motion sickness often precedes or accompanies disorientation and may further jeopardize the flight.

Disorientation in low visibility conditions is not limited to VFR pilots. Although IFR pilots are trained to look at their instruments to gain an artificial visual reference as a replacement for the loss of a visual horizon, they do not always do so. This can happen when the pilot's physical condition will not permit him to concentrate on his instruments; when the pilot is not proficient in flying instrument conditions in the airplane he is flying; or, when the pilot's work load of flying by reference to his instruments is augmented by such factors as turbulence. Even an instrument rated pilot encountering instrument conditions, intentional or unintentional, should ask himself whether or not he is sufficiently alert and proficient in the airplane he is flying, to fly under low visibility conditions and in the turbulence anticipated or encountered.

If any doubt exists, the flight should not be made or it should be discontinued as soon as possible.

The result of vertigo is loss of control of the airplane. If the loss of control is sustained, it will result in an excessive speed accident. Excessive speed accidents occur in one of two manners, either as an inflight airframe separation or as a high speed ground impact; and they are fatal accidents in either case. All airplanes are subject to this form of accident.

For years, Beech Pilot's Operating Handbooks and FAA Approved Airplane Flight Manuals have contained instructions that the landing gear should be extended in any circumstance in which the pilot encounters IFR conditions

which approach the limits of his capability or his ratings. Lowering the gear in IFR conditions or flight into heavy or severe turbulence, tends to stabilize the airplane, assists in maintaining proper airspeed, and will substantially reduce the possibility of reaching excessive airspeeds with catastrophic consequences, even where loss of control is experienced.

Excessive speed accidents occur at airspeeds greatly in excess of two operating limitations which are specified in the manuals: Maximum maneuvering speed and the "red line" or maximum operating speed. Such speed limits are set to protect the structure of an airplane. For example, flight controls are designed to be used to their fullest extent only below the airplane's maximum maneuvering speed. As a result, the control surfaces should never be suddenly or fully deflected above maximum maneuvering speed. Turbulence penetration should not be performed above that speed. The accidents we are discussing here occur at airspeeds greatly in excess of these limitations. No airplane should ever be flown beyond its FAA approved operating limitations.

FLIGHT OF MULTI-ENGINE AIRPLANES WITH ONE ENGINE INOPERATIVE

The major difference between flying a twin-engine and single-engine airplane is knowing how to manage the flight if one engine loses power for any reason. Safe flight with one engine inoperative requires an understanding of the basic aerodynamics involved - as well as proficiency in engine out procedures.

Loss of power from one engine affects both climb performance and controllability of twin-engine airplanes. Climb performance depends on an excess of power over that required for level flight. Loss of power from one engine obviously represents a 50% loss of horsepower but, in virtually all twin-engine airplanes, climb performance is reduced by at least 80%. A study of the charts in your Pilot's Operating

Handbook and FAA Approved Airplane Flight Manual will confirm this fact. Single-engine climb performance depends on four factors:

Airspeed	too little, or too much, will decrease climb performance
Drag	gear, flaps, cowl flaps, prop, and speed
Power	amount available in excess of that needed for level flight
Weight	passengers, baggage, and fuel load greatly affect climb performance

Loss of power on one engine creates yaw due to asymmetric thrust. Yaw forces must be balanced with the rudder. Loss of power on one engine also reduces airflow over the wing causing a roll toward the "dead" engine which must be balanced with the aileron. The net result of these forces cause the airplane to sideslip slightly toward the dead engine. This sideslip may be balanced by banking slightly (up to 5°) into the operating engine.

CAUTION

In the event of an engine failure with the main tanks less than one-quarter full, corrective action must be taken immediately to prevent large yaw angles from developing and causing stoppage of the remaining engine.

Airspeed is the key to safe single engine operations. For most twin-engine airplanes there is:

Symbol	Description
V_{MCA}	Airspeed below which directional control cannot be maintained
V_{SSE}	Airspeed below which an intentional engine cut should never be made
V_{YSE}	Airspeed that will give the best single engine rate-of-climb (or the slowest loss of altitude)
V_{XSE}	Airspeed that will give the steepest angle-of-climb with one engine out

AIR MINIMUM CONTROL SPEED (V_{MCA})

V_{MCA} is designated by the red radial on the airspeed indicator and indicates the minimum control speed, airborne at sea level. V_{MCA} is determined by FAA regulations as the minimum airspeed at which it is possible to recover directional control of the airplane within 20 degrees heading change, and thereafter maintain straight flight, with not more than 5 degrees of bank if one engine fails suddenly with:

- Takeoff power on both engines
- Rearmost allowable center of gravity
- Flaps in takeoff position
- Propeller windmilling in takeoff pitch configuration

However, sudden engine failures rarely occur with all factors listed above, and therefore, the actual V_{MCA} in any particular situation may be a little slower than the red radial on the airspeed indicator. Most airplanes with an inoperative engine will not maintain level flight at maximum power at speeds at or near V_{MCA}. Consequently, it is not advisable to fly at speeds approaching V_{MCA}, except in training situations or during flight tests. Adhering to the practice of never flying at or below the published V_{MCA} speed for your airplane does not eliminate loss of directional control as a problem in the

event of an engine failure. The pilot must be prepared to use assertive control input to maintain airplane control following an engine failure.

INTENTIONAL ONE-ENGINE INOPERATIVE SPEED (V_{SSE})

V_{SSE} is specified by the airplane manufacturer and is the minimum speed at which to perform intentional engine cuts. Use of V_{SSE} is intended to reduce the accident potential from loss of control after engine cuts at or near minimum control speed. V_{MCA} demonstrations are necessary in training but should only be made at safe altitude above the terrain and with power reduction on one engine made at or above V_{SSE} .

ONE-ENGINE-INOPERATIVE BEST RATE-OF-CLIMB SPEED (V_{YSE})

V_{YSE} is designated by the blue radial on the airspeed indicator. V_{YSE} delivers the greatest gain in altitude in the shortest possible time, and is based on the following criteria:

- Critical engine inoperative, and its propeller in the minimum drag position.
- Operating engine set at not more than the maximum continuous power.
- Landing gear retracted.
- Wing flaps up.
- Cowl flaps as required for engine cooling.
- Airplanes flown at recommended bank angle (up to 5° into operating engine).

Drag caused by a windmilling propeller, extending landing gear, or flaps in the landing position, will severely degrade or destroy single engine climb performance. Since climb

performance varies widely with type of airplane, weight, temperature, altitude, and airplane configuration, the climb gradient (altitude gain or loss per mile) may be marginal - or even negative - under some conditions. Study the Pilot's Operating Handbook and FAA Approved Airplane Flight Manual for your airplane and know what performance to expect with one engine out.

ONE-ENGINE-INOPERATIVE BEST ANGLE-OF-CLIMB SPEED (V_{XSE})

V_{XSE} is used only to clear obstructions during initial climb-out as it gives the greatest altitude gain per unit of horizontal distance. It provides less engine cooling and requires more rudder control input than V_{YSE} .

SINGLE ENGINE SERVICE CEILING

The single engine service ceiling is the maximum altitude at which an airplane will climb at a rate of at least 50 feet per minute in smooth air, with one engine inoperative.

The single engine service ceiling chart should be used during flight planning to determine whether the airplane, as loaded, can maintain the Minimum En Route Altitude (MEA) if IFR, or terrain clearance if VFR, following an engine failure.

BASIC SINGLE ENGINE PROCEDURES

Know and follow, to the letter, the single-engine emergency procedures specified in your Pilot's Operating Handbook and FAA Approved Airplane Flight Manual for your specific make and model airplane. However, the basic fundamentals of all the procedures are as follows:

1. Maintain airplane control and airspeed at all times.
THIS IS CARDINAL RULE NUMBER ONE.
2. Usually, apply maximum power to the operating engine.

However, if the engine failure occurs at a speed below V_{MCA} , during cruise or in a steep turn, you may elect to use only enough power to maintain a safe speed and altitude. If the failure occurs on final approach, use power only as necessary to complete the landing.

3. Reduce drag to an absolute minimum.
4. Secure the failed engine and related sub-systems.

The first three steps should be done promptly and from memory. The check list should then be consulted to be sure that the inoperative engine is secured properly and that the appropriate switches are placed in the correct position. The airplane must be banked about 5° into the operating engine, with the "slip/skid" ball slightly out of center toward the operating engine, to achieve rated performance.

Another note of caution: Be sure to identify the dead engine, positively, before securing it. Remember: First identify the suspected engine (i.e., "Dead foot means dead engine"), second, verify with cautious throttle movement, then secure.

ENGINE FAILURE ON TAKEOFF

If an engine fails before attaining lift-off speed or below V_{MCA} , the only proper action is to discontinue the takeoff. If the engine fails after lift-off with the landing gear still down, the takeoff should still be discontinued if touchdown and roll-out on the remaining runway is still possible.

If you do find yourself in a position of not being able to climb, it is much better to reduce the power on the good engine and land straight ahead than try to force a climb and lose control.

Your Pilot's Operating Handbook and FAA Approved Airplane Flight Manual contains charts that are used in calculating the runway length required to stop if the engine fails

before reaching lift-off speed and also has charts showing the single-engine performance after lift-off.

Study your charts carefully. No airplane is capable of climbing out on one engine under all weight, pressure altitude, and temperature conditions. Know, before you take the actual runway, whether you can maintain control and climb out if you lose an engine while the gear is still down. It may be necessary to off-load some weight, or wait for more favorable temperatures.

WHEN TO FLY V_X , V_Y , V_{XSE} AND V_{YSE}

During normal two-engine operations, always fly V_Y (V_X if necessary for obstacle clearance) on initial climb out. Then, accelerate to your cruise climb airspeed, which may be V_Y plus 10 or 15 knots after you have obtained a safe altitude. Use of cruise climb airspeed will give you better engine cooling, increased inflight visibility and better fuel economy. However, at first indication of an engine failure during climb out, or while on approach, establish V_{YSE} or V_{XSE} , whichever is appropriate. (Consult your Pilot's Operating Handbook and FAA Approved Airplane Flight Manual for specifics.)

STALLS, SLOW FLIGHT AND TRAINING

The stall warning system must be kept operational at all times and must not be deactivated by interruption of circuits, circuit breakers, or fuses. Compliance with this requirement is especially important in all high performance multi-engine airplanes during engine-out practice or stall demonstrations, because the stall speed is critical in all low speed operations of high-performance airplanes.

Training should be accomplished under the supervision of a qualified instructor-pilot, with careful reference to the applicable sections of the FAA Practical Test Standards and FAA Pilot Transition Courses for Complex Single Engine and

Light Twin Engine Airplanes (AC61-9B). In particular, observe carefully the warnings in the Practical Test Standards.

The single-engine stall speed of a twin-engine airplane is generally slightly below the power off (engines idle) stall speed, for a given weight condition. Single-engine stalls should not be conducted in multi-engine airplanes by other than qualified engineering test pilots.

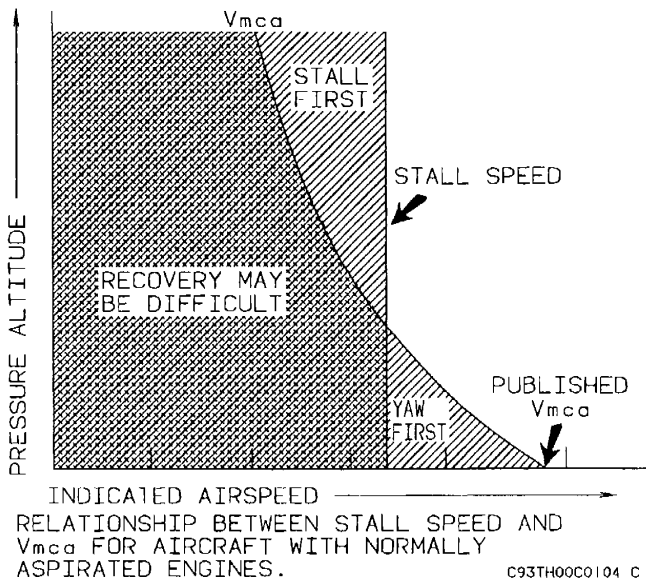

Engine-out minimum control speed generally decreases with altitude, while the single engine stall speed remains approximately constant for normally aspirated engines. No such demonstration should be attempted when the altitude and temperature are such that the engine-out minimum control

speed is known, or discovered to be, close to the stalling speed. Loss of directional or lateral control, just as a stall occurs, is potentially hazardous.

V_{SSE} , the airspeed below which an engine should not be intentionally rendered inoperative for practice purposes, was established because of the apparent practice of some pilots, instructors, and examiners, of intentionally rendering an engine inoperative at a time when the airplane is being operated at a speed close to, or below the power-idle stall speed. Unless the pilot takes immediate and proper corrective action under such circumstances, it is possible to enter an inadvertent spin.

It is recognized that flight below V_{SSE} with one engine inoperative, or simulated inoperative, may be required for conditions such as practice demonstration of V_{MCA} for multi-engine pilot certification. Refer to the procedure set forth in the Pilot's Operating Handbook and FAA Approved Airplane Flight Manual for your airplane. This procedure calls for simulating one engine inoperative by reducing the power level (throttle) on one engine to idle while operating at an airspeed above V_{SSE} . Power on the other engine is set at maximum, then airspeed is reduced at approximately one knot per second until either V_{MCA} or stall warning is obtained. During this transition, rudder should be used to maintain directional control, and ailerons should be used to maintain a 5° bank toward the operative engine. At the first sign of either V_{MCA} or stall warning (which may be evidenced by inability to maintain longitudinal, lateral or directional control, aerodynamic stall buffet, or stall warning horn sound), recovery must be initiated immediately by reducing power to idle on operative engine and lowering the nose to regain V_{SSE} . Resume normal flight. This entire procedure should be used at a safe altitude of at least 5,000 feet above the ground in clear air only.

If stall warning is detected prior to the first sign of V_{MCA} , an engine-out minimum control speed demonstration cannot be

accomplished under the existing gross weight conditions and should not be attempted.

SPINS

A major cause of fatal accidents in general aviation airplanes is a spin. Stall demonstrations and practice are a means for a pilot to acquire the skills to recognize when a stall is about to occur and to recover as soon as the first signs of a stall are evident.

If a stall does not occur - A spin cannot occur. It is important to remember however, that a stall can occur in any flight attitude, at any airspeed, if controls are misused.

Unless your airplane has been specifically certificated in the aerobatic category and specifically tested for spin recovery characteristics, it is placarded against intentional spins. The pilot of an airplane placarded against intentional spins should assume that the airplane may become uncontrollable in a spin, since its performance characteristics beyond certain limits specified in the FAA regulations may not have been tested and are unknown. This is why airplanes are placarded against intentional spins, and this is why stall avoidance is your protection against an inadvertent spin.

Pilots are taught that intentional spins are entered by deliberately inducing a yawing moment with the controls as the airplane is stalled. Inadvertent spins result from the same combination - stall plus yaw. That is why it is important to use coordinated controls and to recover at the first indication of a stall when practicing stalls.

In any twin engine airplane, fundamental aerodynamics dictate that if the airplane is allowed to become fully stalled while one engine is providing lift-producing thrust, the yawing moment which can induce a spin will be present. Consequently, it is important to immediately reduce power on the operating engine, lower the nose to reduce the angle of attack, and increase the airspeed to recover from the stall.

In any twin engine airplane, if application of stall recovery controls is delayed, a rapid rolling and yawing motion may develop, even against full aileron and rudder, resulting in the airplane becoming inverted during the onset of a spinning motion. Once the airplane has been permitted to progress beyond the stall and is allowed to reach the rapid rolling and yawing condition, the pilot must then immediately initiate the generally accepted spin recovery procedure for multi-engine airplanes, which is as follows:

Immediately move the control column full forward, apply full rudder opposite to the direction of the spin and reduce power on both engines to idle. These three actions should be done as near simultaneously as possible; then continue to hold this control position until rotation stops, then neutralize all controls and execute a smooth pullout. Ailerons should be neutral during recovery. **THE LONGER THE PILOT DELAYS BEFORE TAKING CORRECTIVE ACTION, THE MORE DIFFICULT RECOVERY WILL BECOME.**

Always remember that extra alertness and pilot techniques are required for slow flight maneuvers, including the practice or demonstration of stalls or V_{MCA} . In addition to the foregoing mandatory procedure, always:

- Be certain that the center of gravity of the airplane is as far forward as possible. Forward C.G. aids stall recovery, spin avoidance and spin recovery. An aft C.G. can create a tendency for a spin to stabilize, which delays recovery.
- Whenever a student pilot will be required to practice slow flight or single-engine maneuvers, be certain that the qualified instructor pilot has a full set of operable controls available. FAA regulations prohibit flight instruction without full dual controls.
- Conduct any maneuvers which could possibly result in a spin at altitudes in excess of five thousand (5,000) feet above ground level in clear air only.

- Remember that an airplane, at or near traffic pattern and approach altitudes, cannot recover from a spin, or perhaps even a stall, before impact with the ground. For twin engine airplanes, when descending to traffic altitude and during pattern entry and all other flight operations, maintain speed no lower than V_{SSE} . On final approach maintain at least the airspeed shown in the flight manual. Should a go-around be required, do not apply more power than necessary until the airplane has accelerated to V_{SSE} . Recognize that under some conditions of weight, density altitude, and airplane configuration, a twin engine airplane cannot climb or accelerate on a single engine. Hence a single engine go-around is impossible and the airplane is committed to a landing. Plan your approach accordingly.
- Remember that if an airplane flown under instrument conditions is permitted to stall or enter a spin, the pilot, without reference to the horizon, is certain to become disoriented. He may be unable to recognize a stall, spin entry, or the spin condition and he may be unable to determine even the direction of the rotation.
- Finally, never forget that stall avoidance is your best protection against an inadvertent spin. **MAINTAIN YOUR AIRSPEED.**

DESCENT

In twin engine piston-powered airplanes, supercharged or normally aspirated, it is necessary to avoid prolonged descents with low power, as this produces two problems: (1) excessively cool cylinder head temperatures which cause premature engine wear, and (2) excessively rich mixtures due to idle enrichment (and altitude) which causes soot and lead deposits on the spark plugs (fouling). The second of these is the more serious consideration; the engine may not respond to the throttle when it is desired to discontinue the descent. Both problems are amenable to one solution: maintain adequate power to keep cylinder head temperatures in

the "green" range during descent, and lean to best power mixture (that is, progressively enrich the mixture from cruise only slightly as altitude decreases). This procedure will lengthen the descent, of course, and requires some advance planning. If it is necessary to make a prolonged descent at or near idle, as in practicing forced landings, at least avoid the problem of fouled spark plugs by frequently advancing the throttle until the engine runs smoothly, and maintain an appropriate mixture setting with altitude. (Refer to pre-landing check list.)

VORTICES - WAKE TURBULENCE

Every airplane generates wakes of turbulence while in flight. Part of this is from the propeller or jet engine, and part from the wing tip vortices. The larger and heavier the airplane, the more pronounced and turbulent the wakes will be. Wing tip vortices from large, heavy airplanes are very severe at close range, degenerating with time, wind and distance. These are rolling in nature, from each wing tip. In tests, vortex velocities of 133 knots have been recorded. Encountering the rolling effect of wing tip vortices within two minutes after passage of large airplanes is most hazardous to light airplanes. This roll effect can exceed the maximum counter-roll obtainable in a light airplane. The turbulent areas may remain for as long as three minutes or more, depending on wind conditions, and may extend several miles behind the airplane. Plan to fly slightly above and to the windward side of other airplanes. Because of the wide variety of conditions that can be encountered, there is no set rule to follow to avoid wake turbulence in all situations. However, the Airman's Information Manual, and to a greater extent Advisory Circular 90-23, Aircraft Wake Turbulence, provide a thorough discussion of the factors you should be aware of when wake turbulence may be encountered.

TAKEOFF AND LANDING CONDITIONS

When taking off on runways covered with water or freezing slush, the landing gear should remain extended for approximately ten seconds longer than normal, allowing the wheels to spin and dissipate the freezing moisture. The landing gear should then be cycled up, then down, wait approximately five seconds and then retracted again. Caution must be exercised to insure that the entire operation is performed below Maximum Landing Gear Operating Airspeed.

Use caution when landing on runways that are covered by water or slush which cause hydroplaning (aquaplaning), a phenomenon that renders braking and steering ineffective because of the lack of sufficient surface friction. Snow and ice covered runways are also hazardous. The pilot should also be alert to the possibility of the brakes freezing.

Use caution when taking off or landing during gusty wind conditions. Also be aware of the special wind conditions caused by buildings or other obstructions located near the runway.

MEDICAL FACTS FOR PILOTS

GENERAL

When the pilot enters the airplane, he becomes an integral part of the man-machine system. He is just as essential to a successful flight as the control surfaces. To ignore the pilot in preflight planning would be as senseless as failing to inspect the integrity of the control surfaces or any other vital part of the machine. The pilot has the responsibility for determining his reliability prior to entering the airplane for flight. When piloting an airplane, an individual should be free of conditions which are harmful to alertness, ability to make correct decisions, and rapid reaction time.

FATIGUE

Fatigue generally slows reaction time and causes errors due to inattention. In addition to the most common cause of fatigue; insufficient rest and loss of sleep, the pressures of business, financial worries, and family problems can be important contributing factors. If you are tired, don't fly.

HYPOXIA

Hypoxia, in simple terms, is a lack of sufficient oxygen to keep the brain and other body tissues functioning properly. There is a wide individual variation in susceptibility to hypoxia. In addition to progressively insufficient oxygen at higher altitudes, anything interfering with the blood's ability to carry oxygen can contribute to hypoxia (anemias, carbon monoxide, and certain drugs). Also, alcohol and various drugs decrease the brain's tolerance to hypoxia.

Your body has no built-in alarm system to let you know when you are not getting enough oxygen. It is impossible to predict when or where hypoxia will occur during a given flight, or how it will manifest itself. Some of the common symptoms of hypoxia are increased breathing rate, a light-headed or dizzy sensation, tingling or warm sensation, sweating, reduced visual field, sleepiness, blue coloring of skin, fingernails, and lips, and behavior changes. A particularly dangerous feature of hypoxia is an increased sense of well-being, called euphoria. It obscures a person's ability and desire to be critical of himself, slows reaction time, and impairs thinking ability. Consequently, a hypoxic individual commonly believes things are getting progressively better while he nears total collapse.

The symptoms are slow but progressive, insidious in onset, and are most marked at altitudes starting above ten thousand feet. Night vision, however, can be impaired starting at an altitude of 5,000 feet. Persons who have recently overindulged in alcohol, who are moderate to heavy smokers, or

who take certain drugs, may be more susceptible to hypoxia. Susceptibility may also vary in the same individual from day to day or even morning to evening. Use oxygen on flights above 10,000 feet and at any time when symptoms appear.

Depending upon altitude, a hypoxic individual has a limited time to make decisions and perform useful acts, even though he may remain conscious for a longer period. If pressurization equipment fails at certain altitudes the pilot and passengers have only a certain amount of time to get an oxygen mask on before they exceed their time of useful consciousness. The time of useful consciousness is approximately 3-5 minutes at 25,000 feet of altitude for the average individual and diminishes markedly as altitude increases. At 30,000 feet altitude, for example, the time of useful consciousness is approximately 1-2 minutes. Therefore, in the event of depressurization, oxygen masks should be used immediately.

Should symptoms occur that cannot definitely be identified as either hypoxia or hyperventilation, try three or four deep breaths of oxygen. The symptoms should improve markedly if the condition was hypoxia (recovery from hypoxia is rapid).

Pilots who fly to altitudes that require or may require the use of supplemental oxygen should be thoroughly familiar with the operation of the airplane oxygen systems. A preflight inspection of the system should be performed, including proper fit of the mask. The passengers should be briefed on the proper use of their oxygen system before flight.

Pilots who wear beards should be careful to ensure that their beard is carefully trimmed so that it will not interfere with proper sealing of the oxygen masks. If you wear a beard or moustache, test the fit of your oxygen mask on the ground for proper sealing. Studies conducted by the military and oxygen equipment manufacturers conclude that oxygen masks do not seal over beards or heavy facial hair.

Federal Aviation Regulations related to the use of supplemental oxygen by flight crew and passengers must be adhered to if flight to higher altitudes is to be accomplished safely. Passengers with significant circulatory or lung disease may need to use supplemental oxygen at lower altitudes than specified by these regulations.

Pilots of pressurized airplanes should receive physiological training with emphasis on hypoxia and the use of oxygen and oxygen systems. Pilots of airplanes with pressure demand oxygen systems should undergo training, experience altitude chamber decompression, and be familiar with pressure breathing before flying at high altitude. This training is available throughout the United States at nominal cost. Information regarding this training may be obtained by request from the Chief, Civil Aeromedical Institute, Attention: Aeromedical Education Branch, AAC-140, Mike Monroney Aeronautical Center, P. O. Box 25082, Oklahoma City, Oklahoma 73125

HYPERVENTILATION

Hyperventilation, or overbreathing, is a disturbance of respiration that may occur in individuals as a result of emotional tension or anxiety. Under conditions of emotional stress, fright, or pain, breathing rate may increase, causing increased lung ventilation, although the carbon dioxide output of the body cells does not increase. As a result, carbon dioxide is "washed out" of the blood. The most common symptoms of hyperventilation are: dizziness, nausea, sleepiness, and finally, unconsciousness. If the symptoms persist discontinue use of oxygen and consciously slow your breathing rate until symptoms clear, and then resume normal breathing rate. Normal breathing can be aided by talking aloud.

ALCOHOL

Common sense and scientific evidence dictate that you must not fly as a crew member while under the influence of alcohol. Alcohol, even in small amounts, produces (among other things):

- A dulling of critical judgement.
- A decreased sense of responsibility.
- Diminished skill reactions and coordination.
- Decreased speed and strength of muscular reflexes (even after one ounce of alcohol).
- Decreases in efficiency of eye movements during reading (after one ounce of alcohol).
- Increased frequency of errors (after one ounce of alcohol).
- Constriction of visual fields.
- Decreased ability to see under dim illuminations.
- Loss of efficiency of sense of touch.
- Decrease of memory and reasoning ability.
- Increased susceptibility to fatigue and decreased attention span.
- Decreased relevance of response.
- Increased self confidence with decreased insight into immediate capabilities.

Tests have shown that pilots commit major errors of judgment and procedure at blood alcohol levels substantially less than the minimum legal levels of intoxication for most states. These tests further show a continuation of impairment from alcohol up to as many as 14 hours after consumption, with no appreciable diminution of impairment. The body metabolizes ingested alcohol at a rate of about one-third of an ounce per hour. Even after the body completely

destroys a moderate amount of alcohol, a pilot can still be severely impaired for many hours by hangover. The effects of alcohol on the body are magnified at altitudes, as 2 oz. of alcohol at 18,000 feet produce the same adverse effects as 6 oz. at sea level.

Federal Aviation Regulations have been amended to reflect the FAA's growing concern with the effects of alcohol impairment. FAR 91 states:

"Alcohol or drugs.

(a) No person may act or attempt to act as a crew-member of a civil aircraft -

- (1) Within 8 hours after the consumption of any alcoholic beverage;
- (2) While under the influence of alcohol;
- (3) While using any drug that affects the person's faculties in any way contrary to safety; or
- (4) While having .04 percent by weight or more alcohol in the blood.

(b) Except in an emergency, no pilot of a civil aircraft may allow a person who appears to be intoxicated or who demonstrates by manner or physical indications that the individual is under the influence of drugs (except a medical patient under proper care) to be carried in that aircraft."

Because of the slow destruction of alcohol by the body, a pilot may still be under influence eight hours after drinking a moderate amount of alcohol. Therefore, an excellent rule is to allow at least 12 to 24 hours between "bottle and throttle," depending on the amount of alcoholic beverage consumed.

DRUGS

Self-medication or taking medicine in any form when you are flying can be extremely hazardous. Even simple home or

over-the-counter remedies and drugs such as aspirin, anti-histamines, cold tablets, cough mixtures, laxatives, tranquilizers, and appetite suppressors, may seriously impair the judgment and coordination needed while flying. The safest rule is to take no medicine before or while flying, except after consultation with your Aviation Medical Examiner.

SCUBA DIVING

Flying shortly after any prolonged scuba diving could be dangerous. Under the increased pressure of the water, excess nitrogen is absorbed into your system. If sufficient time has not elapsed prior to takeoff for your system to rid itself of this excess gas, you may experience the bends at altitudes even under 10,000 feet, where most light planes fly.

CARBON MONOXIDE AND NIGHT VISION

The presence of carbon monoxide results in hypoxia which will affect night vision in the same manner and extent as hypoxia from high altitudes. Even small levels of carbon monoxide have the same effect as an altitude increase of 8,000 to 10,000 feet. Smoking several cigarettes can result in a carbon monoxide saturation sufficient to affect visual sensitivity equal to an increase of 8,000 feet altitude.

DECOMPRESSION SICKNESS

Pilots flying unpressurized airplanes at altitudes in excess of 10,000 feet should be alert for the symptoms of 'decompression sickness'. This phenomenon, while rare, can impair the pilot's ability to perform and in extreme cases, can result in the victim being rendered unconscious. Decompression sickness, also known as dysbarism and aviator's "bends", is caused by nitrogen bubble formation in body tissue as the ambient air pressure is reduced by climbing to higher altitudes. The symptoms are pain in the joints, abdominal cramps, burning sensations in the skin, visual impairment

Section X
Safety Information

Beechcraft
Twin Engine (Piston)

and numbness. Some of these symptoms are similar to hypoxia. The only known remedy for decompression sickness is recompression, which can only be accomplished in an unpressurized airplane by descending. The pilot should immediately descend if it is suspected that this condition exists, since the effects will only worsen with continued exposure to the reduced pressure environment at altitude and could result, if uncorrected, in complete incapacitation. The possibility of decompression sickness can be greatly reduced by pre-breathing oxygen prior to flight and by commencing oxygen breathing well below the altitudes where it is legally mandatory.

A FINAL WORD

Airplanes are truly remarkable machines. They enable us to shrink distance and time, and to expand our business and personal horizons in ways that, not too many years ago, were virtually inconceivable. For many businesses, the general aviation airplane has become the indispensable tool of efficiency.

Advances in the mechanical reliability of the airplanes we fly have been equally impressive, as attested by the steadily declining statistics of accidents attributed to mechanical causes, at a time when the airframe, systems and power plants have grown infinitely more complex. The explosion in capability of avionics systems is even more remarkable. Radar, RNAV, LORAN, sophisticated autopilots and other devices which, just a few years ago, were too large and prohibitively expensive for general aviation size airplanes, are becoming increasingly commonplace in even the smallest airplanes.

It is thus that this Safety Information is directed to the pilot, for it is in the area of the skill and proficiency of you, the pilot, that the greatest gains in safe flying are to be made over the years to come. Intimate knowledge of your airplane, its capabilities and its limitations, and disciplined adherence to the procedures for your airplane's operation, will enable you to transform potential tragedy into an interesting hangar story when - as it inevitably will - the abnormal situation is presented.

Know your airplane's limitations, and your own. Never exceed either.

Safe flying,

BEECH AIRCRAFT CORPORATION

**THIS PAGE INTENTIONALLY LEFT
BLANK**